

AURORA

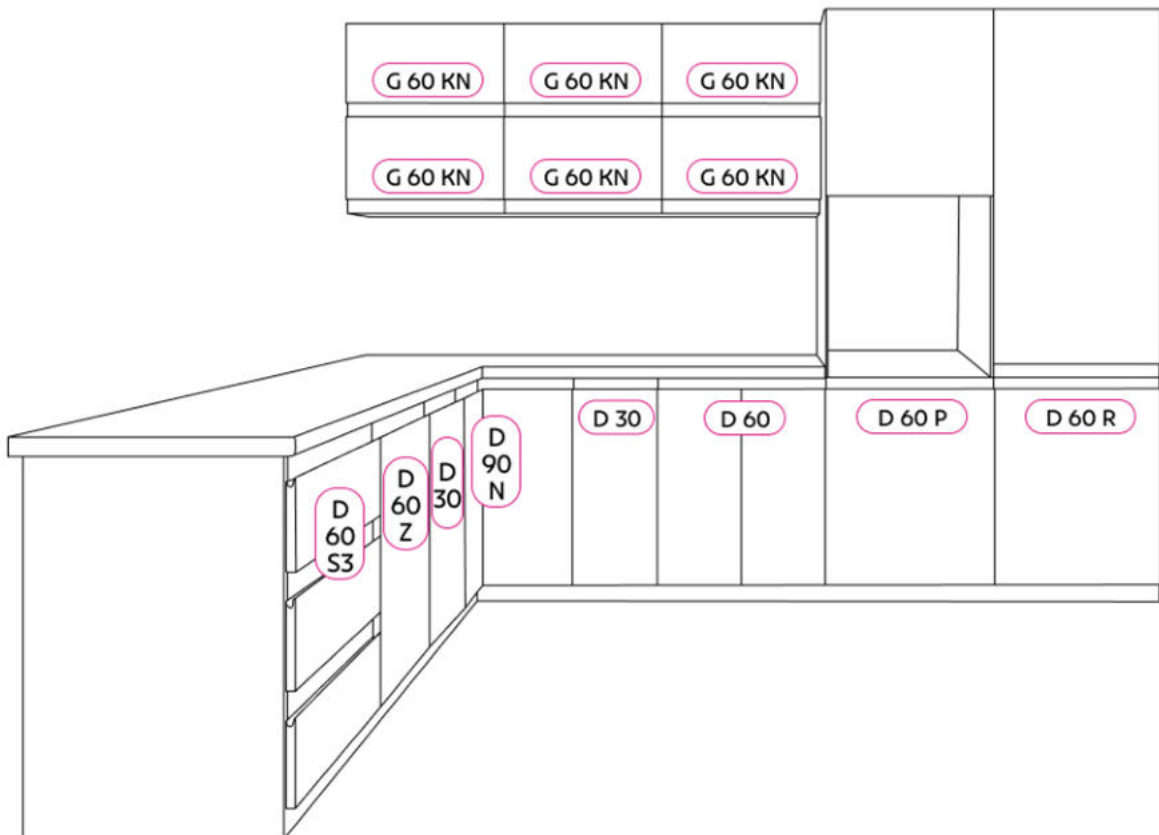
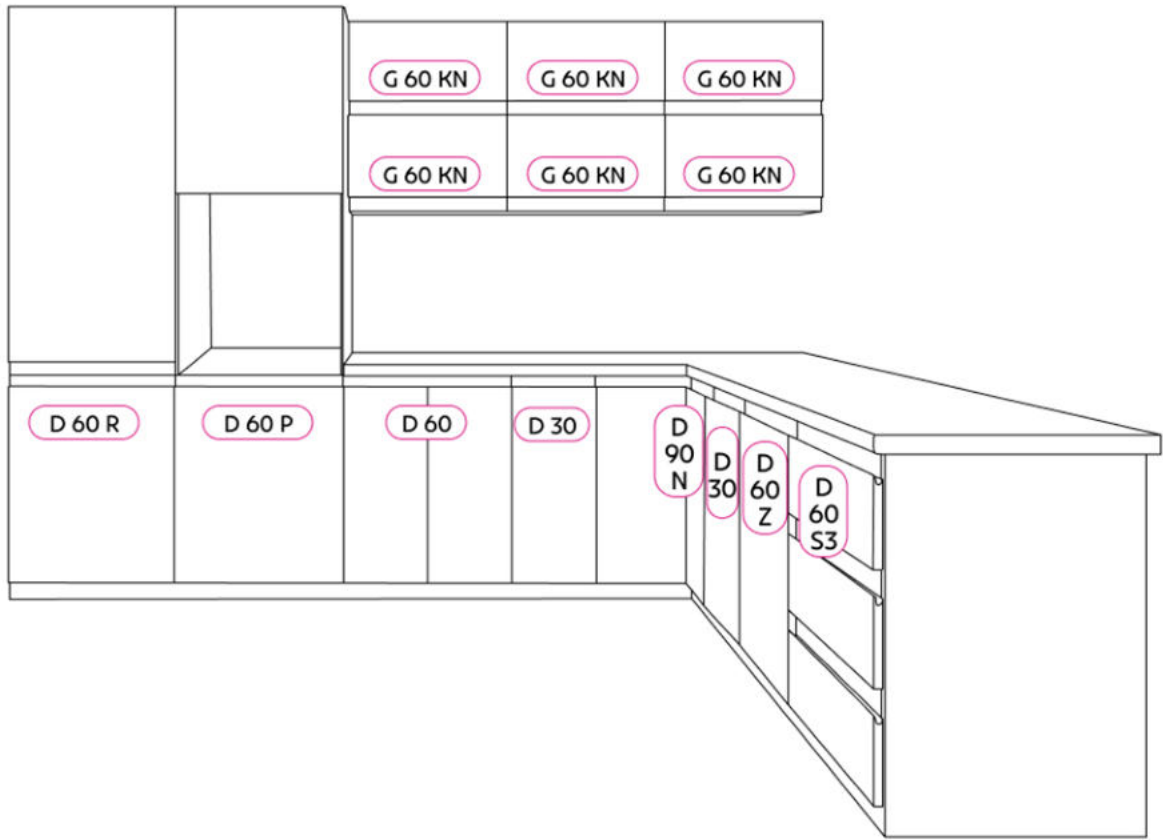

Vážený Zákazníku!

Před montáží nábytku si pečlivě přečtěte následující pokyny

PRVKY NESOUČÍ STOPY MONTÁŽE REKLAMOVANÉ PRO MECHANICKÁ POŠKOZENÍ NEBO VADY NEPODLÉHAJÍ REKLAMACI V případě pochybnosti během montáže nás prosím kontaktujte na telefonní číslo: (+48) 0-71 315 77 52 Od pondělí do pátku v hod. 8-16. Nábytek se sestavuje podle následujících kroků uvedených v příručce. Kódy nalepené na částech nábytku odpovídají kódům v příručce.

Pozor! Kolíky nabijíme do úzké roviny prvku.

Pozor! Zadní stěnu nábytku a spodní část zásuvky montujeme po nastavení úhlopříčky (viz obrázek).

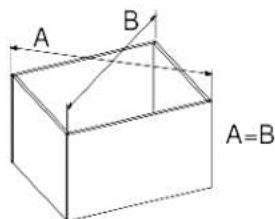

Posledním krokem je umístění nábytku na správné místo a pomocí vodováhy zkontrolování vertikální a horizontální polohy nábytku a nastavení čelních ploch na pantech.

Tipy pro péči.

Nábytek čistíme pouze prachovou utěrkou (suchou nebo vlhkou)! Nepoužívejte žádné chemické čisticí prostředky!

Skleněné prvky prosím čiňte prostředky pro čištění skla, které jsou k dispozici na trhu, a jak je uvedeno na obalu vybraného produktu.

Pozor!

Koloristika dekorativní lišty a obvodu nábytku se může mírně lišit od barvy desky. Závisí to na várce produktu.

Toto NENÍ základem pro reklamaci.

Pozor!

Výrobce nábytku si vyhrazuje právo provádět konstrukční změny nabízeného nábytku, aniž by změnil jeho celkový charakter.

Rozměry nábytku se mohou měnit.

Vážený Zákazníku!

Děkujeme za nákup produktu. Gratulujeme Vám ke kvalitní volbě. Byli bychom velice rádi, kdyby Vám náš nábytek sloužil dlouho a dával Vám satisfakci. Pečlivě si přečtěte podmínky použití a údržby našeho nábytku, aby Vám dlouho přinášel radost.

Hodně jsme se snažili, aby Vámi zakoupený nábytek byl kvalitní, moderní a funkční. Nicméně v případě jakékoliv chyby, prosíme o obrácení se na Prodejce abychom danou chybu jak nejdříve eliminovali.

ZÁRUČNÍ PODMÍNKY

1. Garant zaručuje Kupujícímu dobrou kvalitu a správné fungování nábytku na dobu 24 měsíců od data prodeje nábytku.
2. Kupující při zakoupení smontovaného výrobku je povinen zkontrolovat kvalitu a kompletnost výrobku. Dále je povinen zkontrolovat funkčnost hlavních mechanismů a základních podsestav.
3. Záruka se nevztahuje na poškození, které vzniklo z důvodu neopatrného transportu, neopatrného manévrování nebo chybné montáže, stejně jako se záruka nevztahuje v důsledku vyšší moci nebo poškození, díky kterému cena výrobku byla snížena. Viditelné vady, mechanické poškození a kvantitativní nedostatky elementů a kování v nábytku, které jsou prodávány smontované, kupující musí nahlásit při koupi. V opačném případě záruku nelze uplatnit.
4. Vlastní předělávky nábytku znemožňují uplatnění záruky.
5. Garant neodpovídá za inkompatibilitu produktu se smlouvou, v případě, že kupující o této inkompatibilitě věděl nebo o ní měl vědět.
6. O inkompatibilitě produktu do bodu vlastní montáže je povinen Kupující poinformovat Prodávajícího v průběhu dvou měsíců od zjištění této neshody.
7. Vady, které vznikly v záruční době nebo jiné poškození výrobku je potřeba nahlásit v místě zakoupení produktu, kde je potřeba ukázat záruční list. Prodejce se vyjádří do 14 dnů od nahlášení vady produktu. Pokud se tak nestane, znamená to, že záruka je odůvodněná.
8. Záruční období bude prodlouženo o čas, který uplyne z důvodu řešení reklamace, jestli v tomto období vady neumožňují užívání produktu.
9. V případě, že produkt není v souladu se smlouvou, Garant zaručuje Kupujícímu uvedení do souladu se smlouvou skrze výměnu dané části.
10. V případě, že výměna nábytku proběhne bez závad nebo ukončení smlouvy, kromě vad, které mají za následek výměnu nebo odstoupení od smlouvy, bude zjištěno snížení kvality produktu nad úroveň běžného opotřebení nebo spojeno s předělkou provedenou kupujícím nebo zbožím bude nekompletní (nedostatek komponentů nebo zařízení, které je nepostradatelné při dalším prodeji), bude prodávající účtovat kupujícímu ekvivalent poškozených nebo chybějících položek.

PODMÍNKY PRO POUŽÍVÁNÍ NÁBYTKU

1. Nábytek by měl být použit k zamýšlenému účelu.
2. Nábytek by měl být používán v suchém, uzavřeném a chráněném proti nepříznivým povětrnostním vlivům a přímým působením slunečního záření. Teplota vnitřního vzduchu by měla být v rozmezí od 10 do 30 ° C a relativní vlhkosti 25-80%. Nábytek by neměl být méně než půl metru od aktivních radiátorů.
3. Nábytek má být rozložen na rovném a stabilním povrchu.
4. Způsob montáže nábytku, počet součástí a příslušenství nezbytných pro sestavení určuje informační karta, která se nachází v obalu s kováním.

PODMÍNKY PRO ÚDRŽBU NÁBYTKU

1. Laminátový nábytek čistíme následným způsobem:
- myjeme měkkým, vlhkým hadříkem.
2. Pro mytí povrchu nepoužívejte žádné chemické a abrazivní prostředky.
3. Na plochu nábytku nepokládejte horké a vlhké věci.
4. Renovaci povrchu nábytku svěřte specializovaným firmám.

AURORA

D30

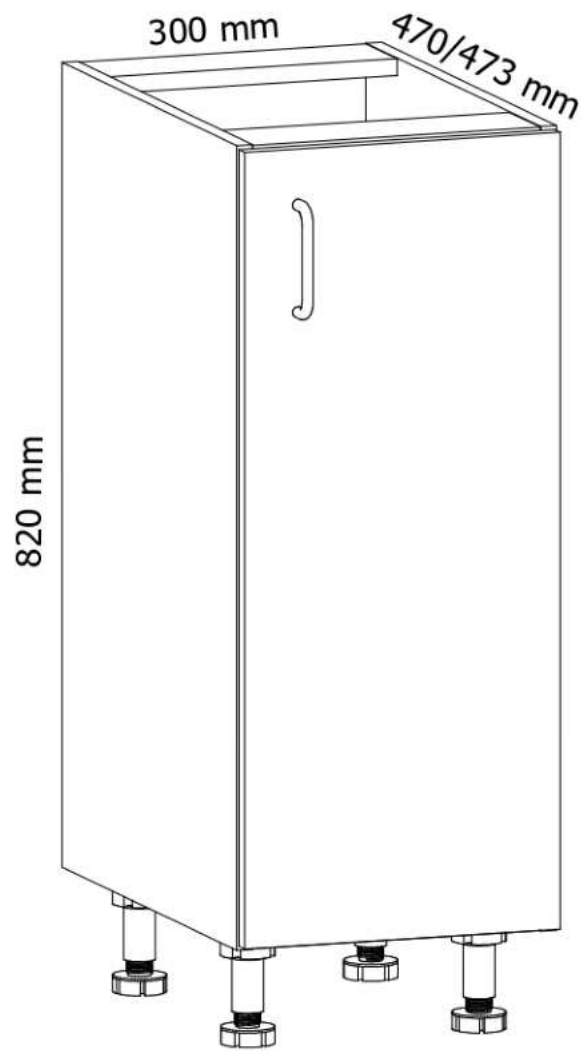

D30(P) / S30

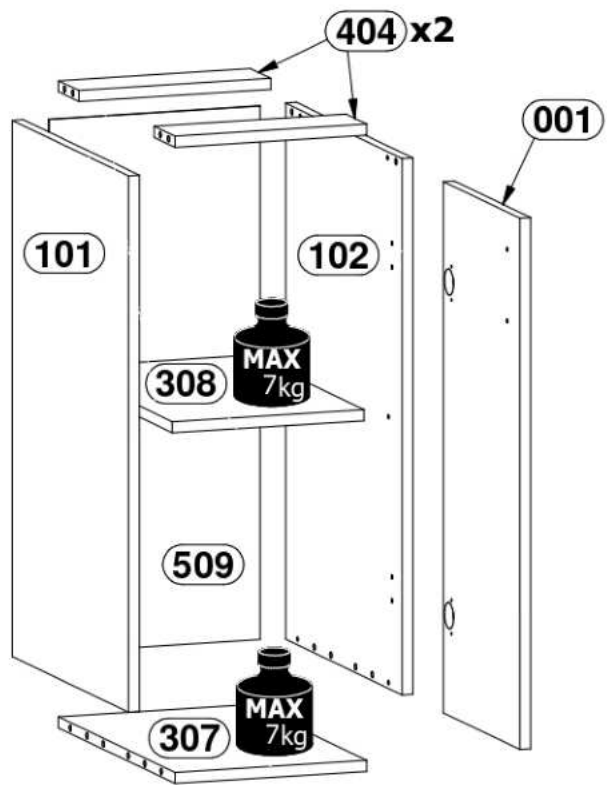
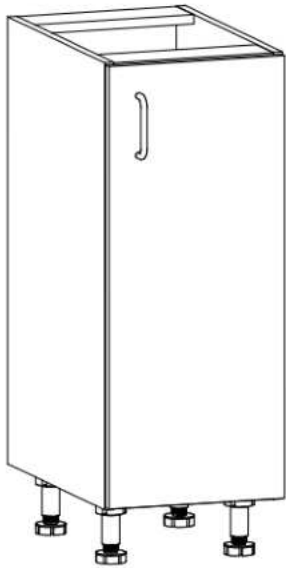

D30(L)

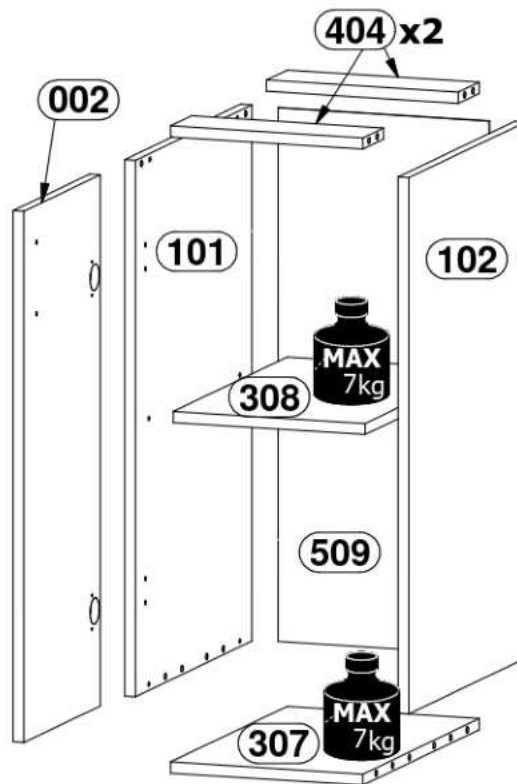
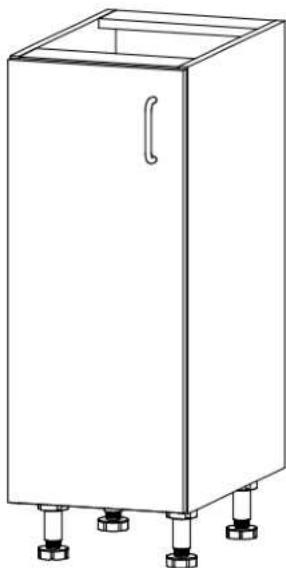

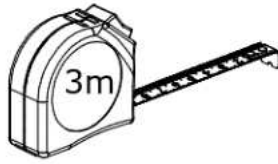
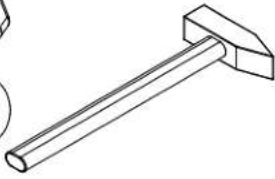
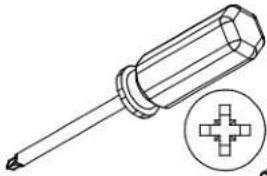

A1 x12

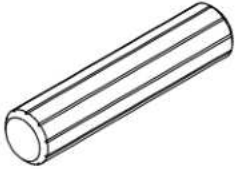

Ø8x35mm

B1 x8



Ø5x38mm

C1 x8

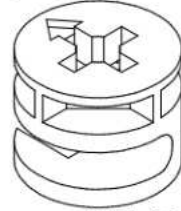

Ø15x12mm

E4 x4

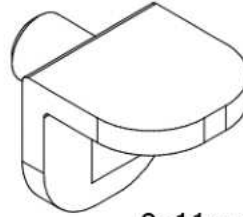

9x11mm

G1 x20

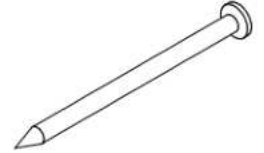

26mm

L1 x4



Ø50x95mm

U x1

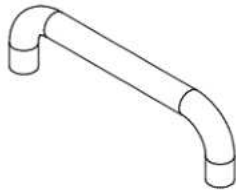

W2 x20

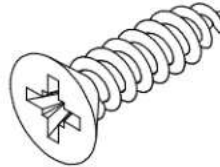

Ø3,5x16mm

X x2

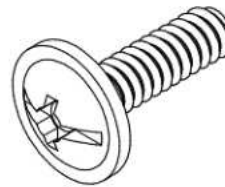

Zc1 x2

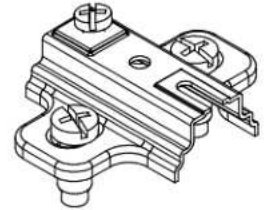

Zc2 x2

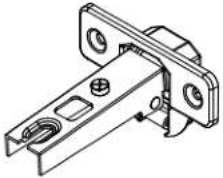

1

B1 x8



E4 x4

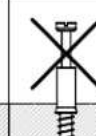
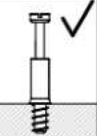
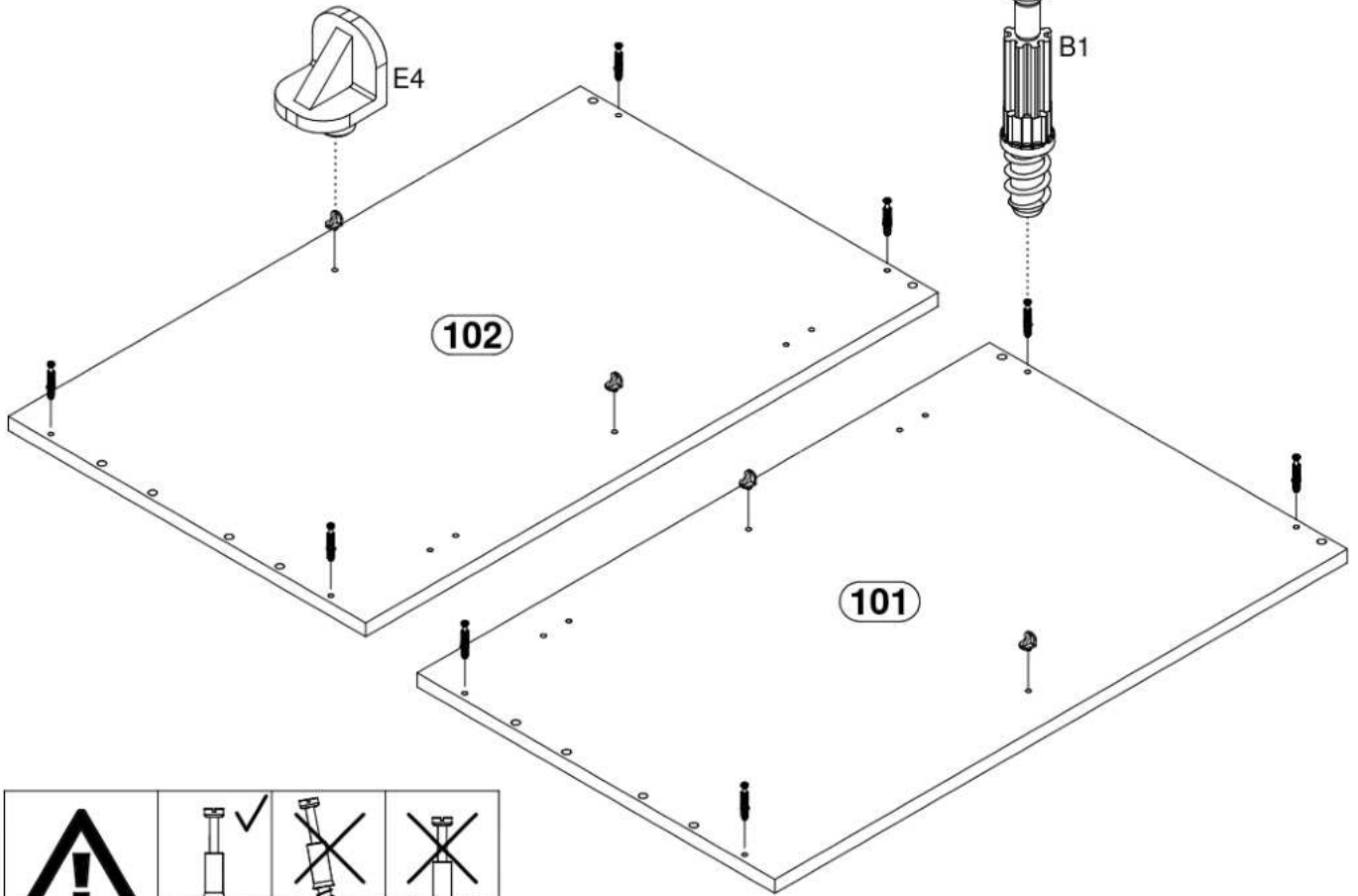
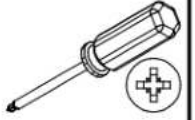
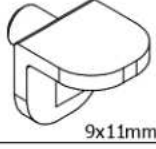

2

A1 x12



C1 x8

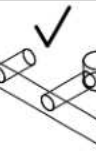
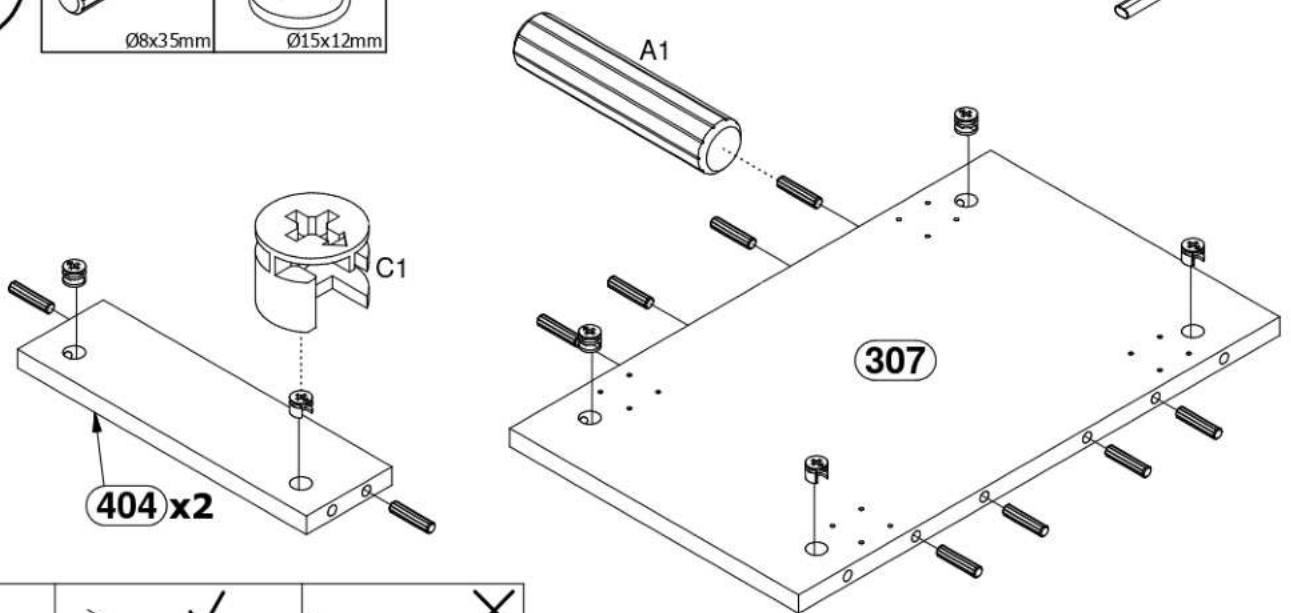

3

L1 x4



Ø50x95mm

W2 x16



Ø3,5x16mm

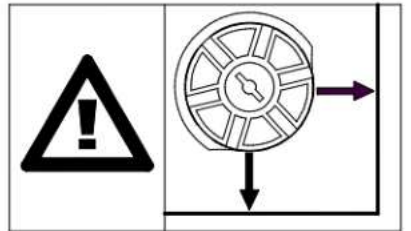
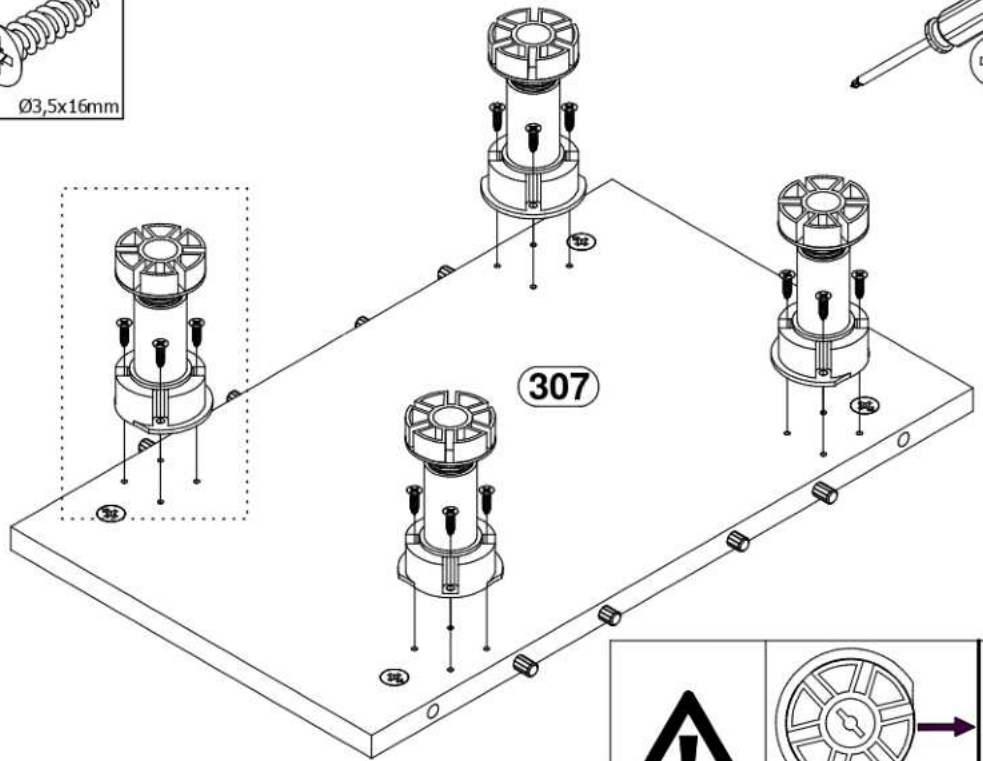
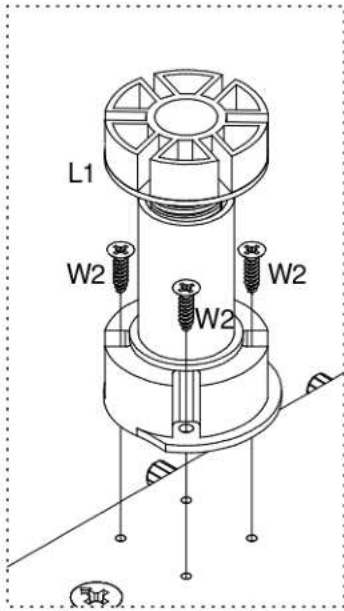
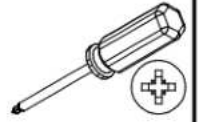

4

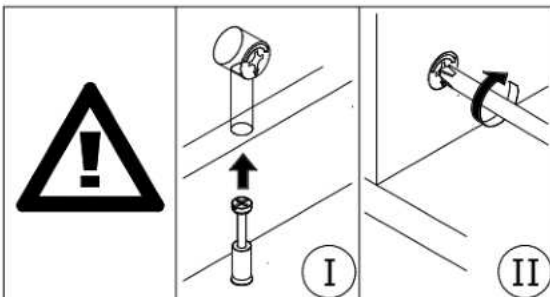
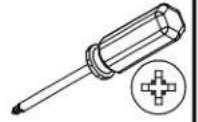
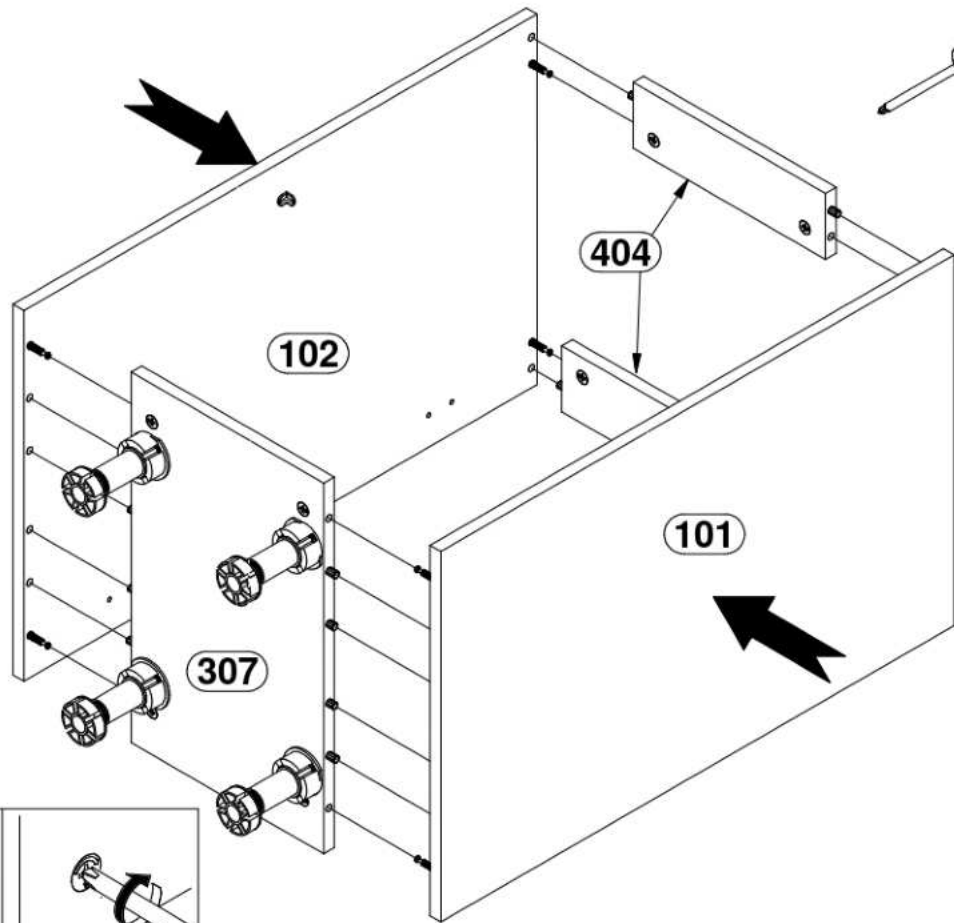

5

G1 x 20



26mm

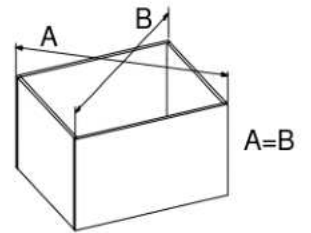
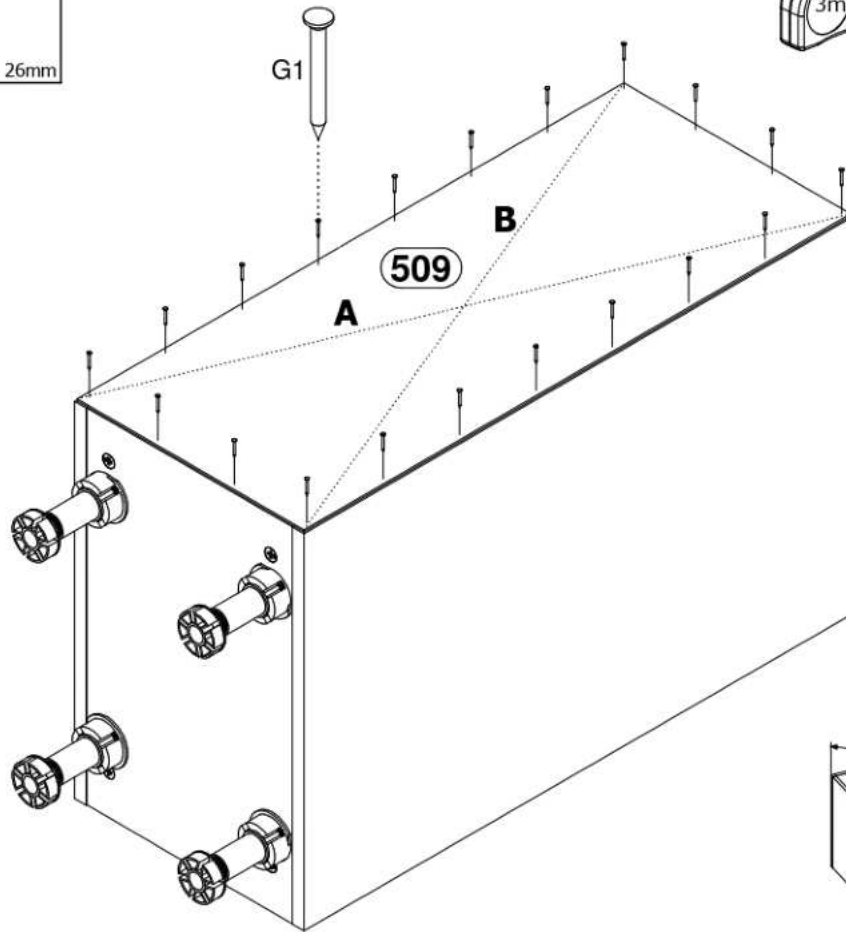
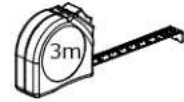

!
A=B \equiv 90°

6

W2 x 4



Ø3,5x16mm

Zc2 x 2

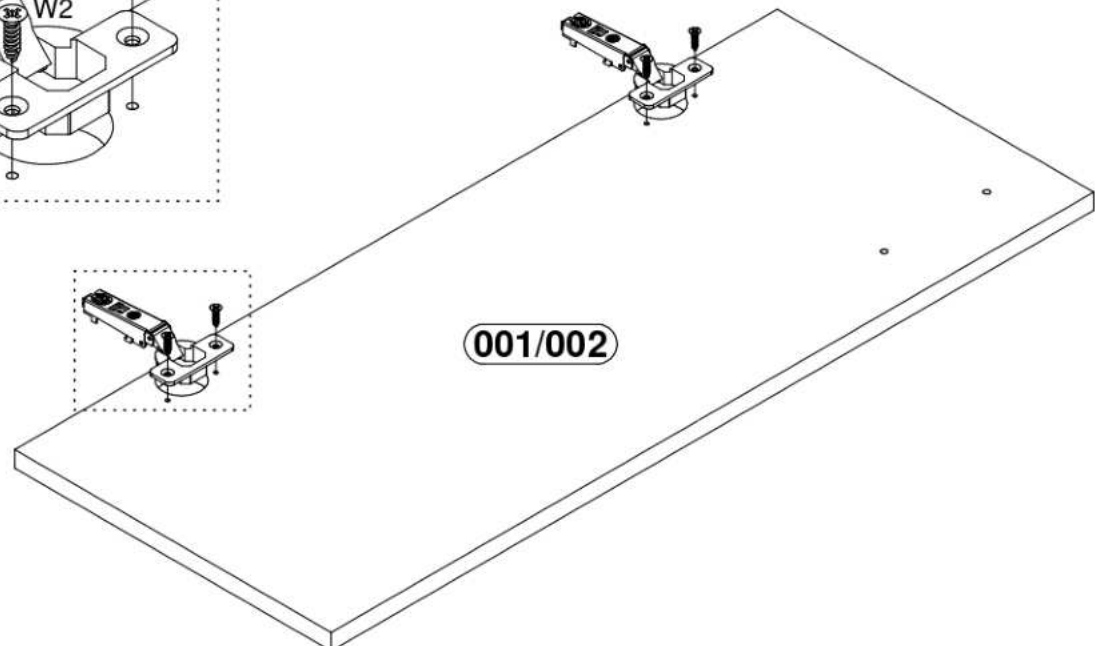
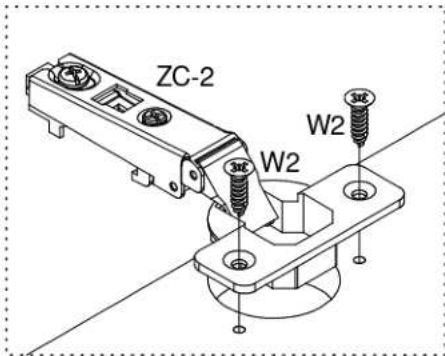
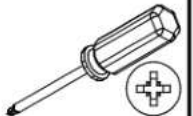

7

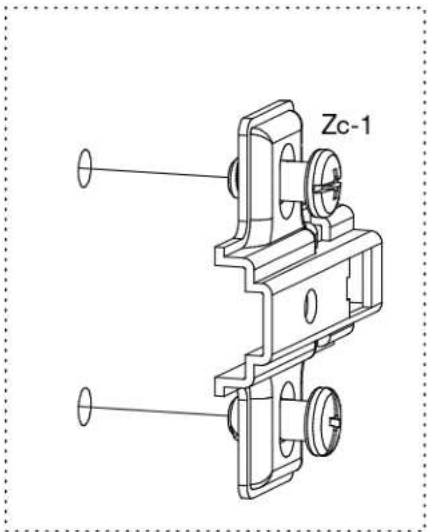
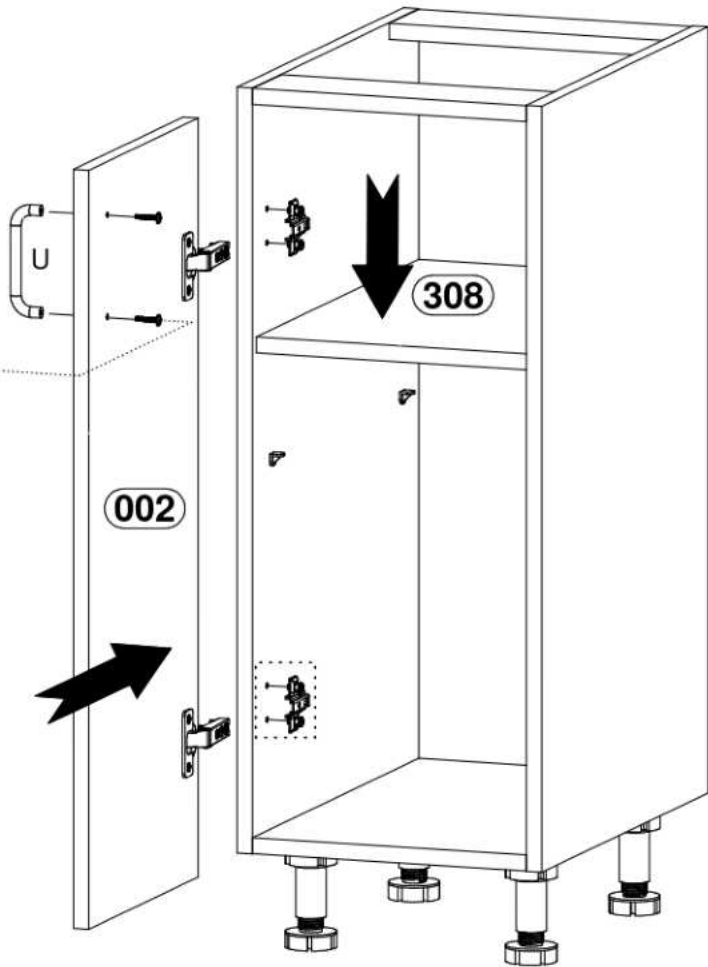
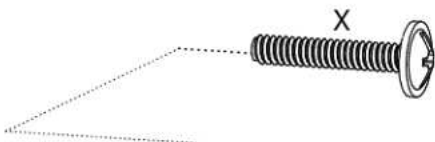
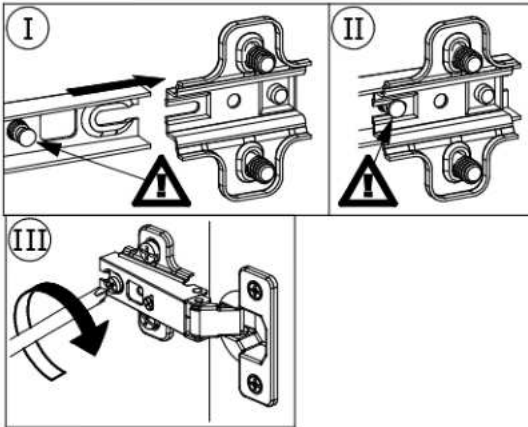
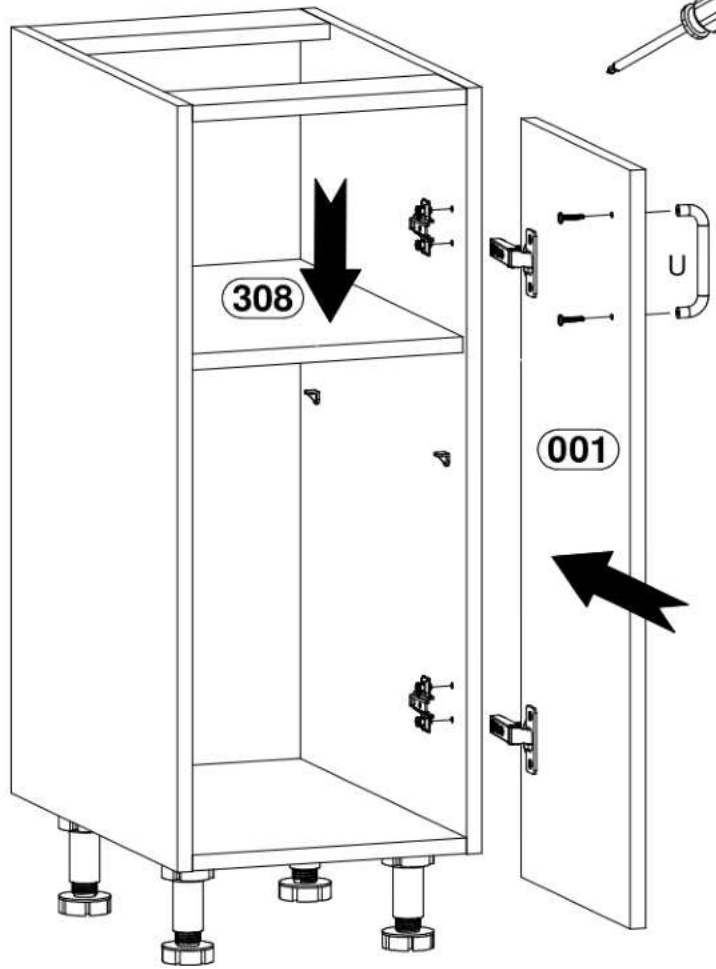
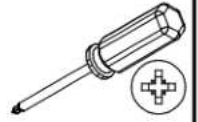
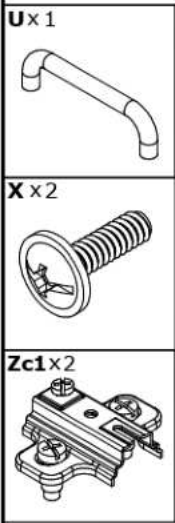

8

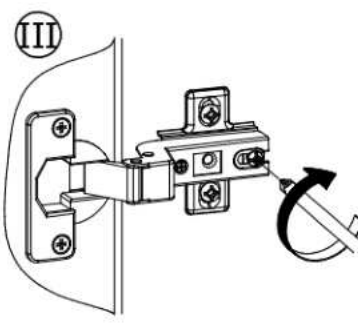
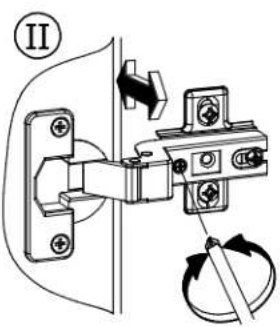
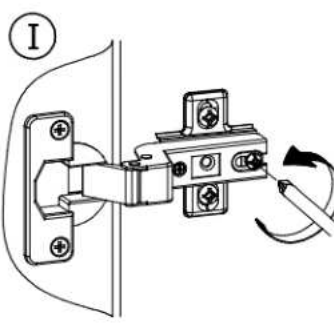
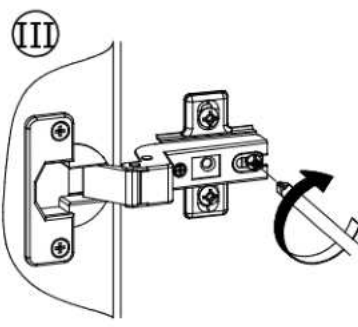
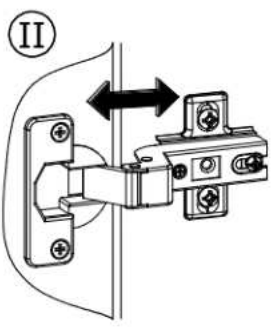
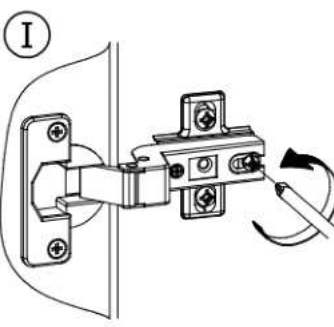
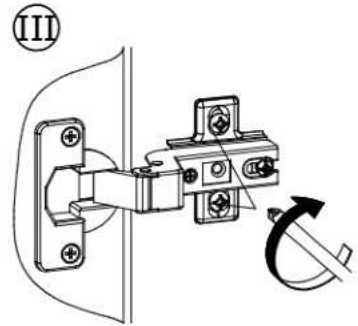
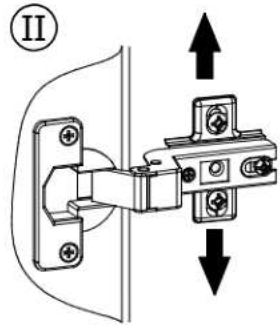
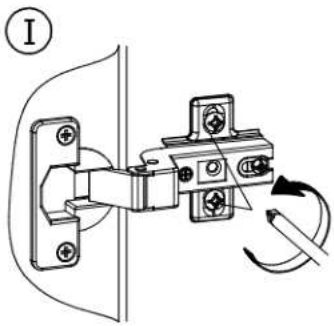
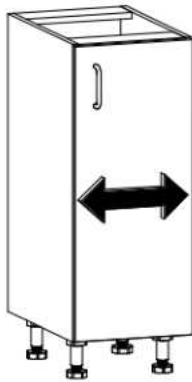
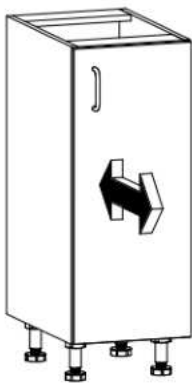
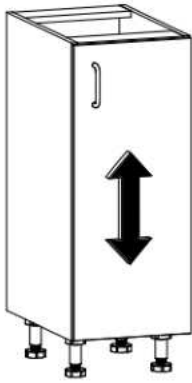
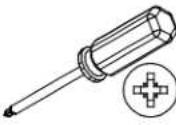

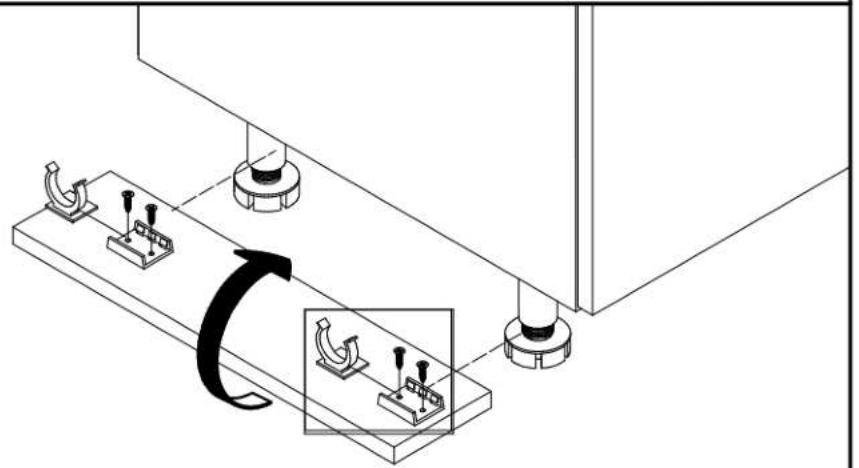
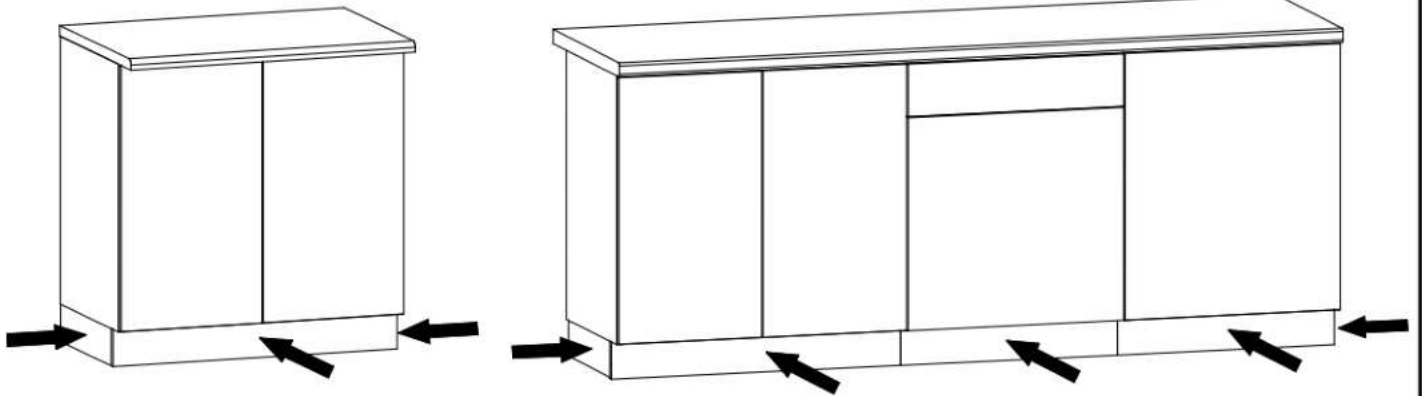
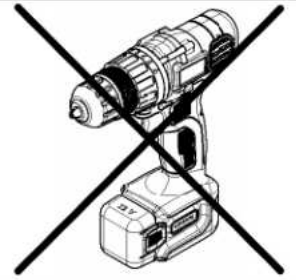
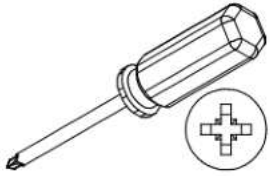

L6-a x4

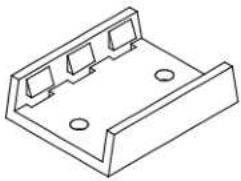

38x30x10mm

L6-b x4

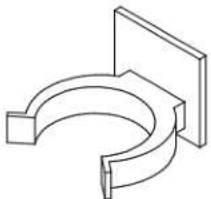

35x32x25mm

W2 x8

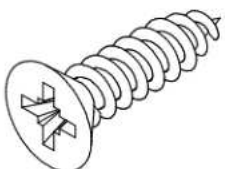

Ø3,5x16mm

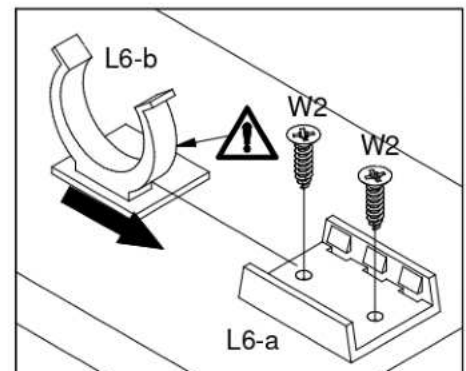

C2

L6-a x2

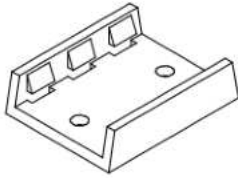

38x30x10mm

L6-b x2

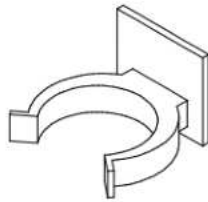

35x32x25mm

W2 x4

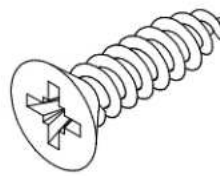

Ø3,5x16mm

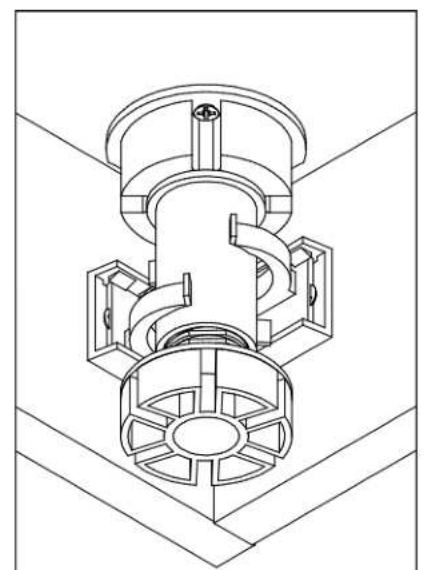
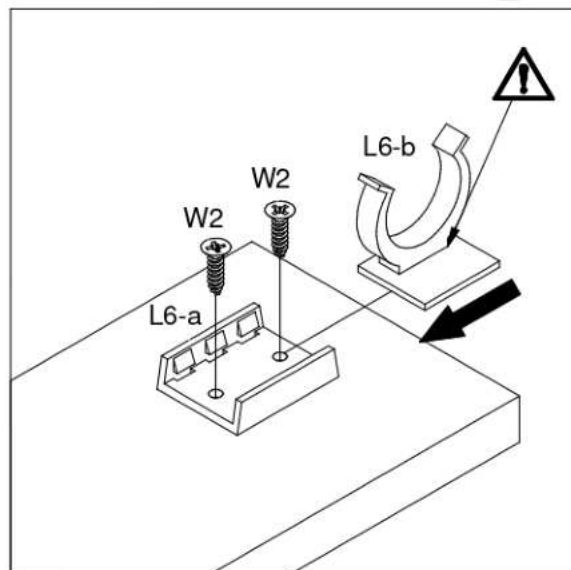
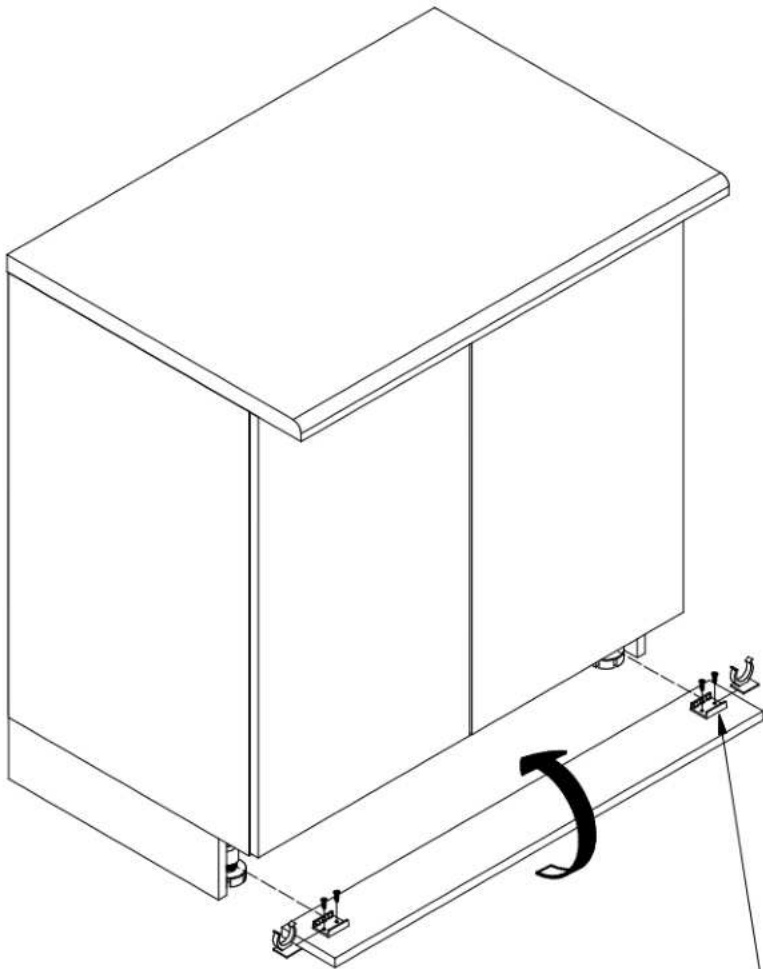
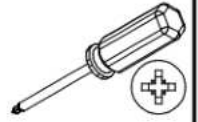

AURORA

D60

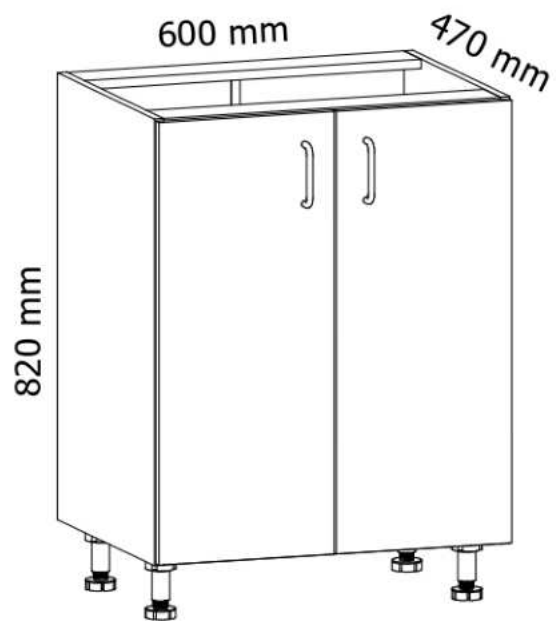



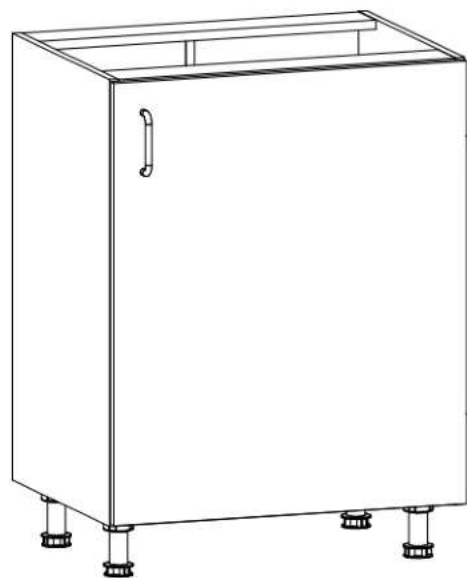
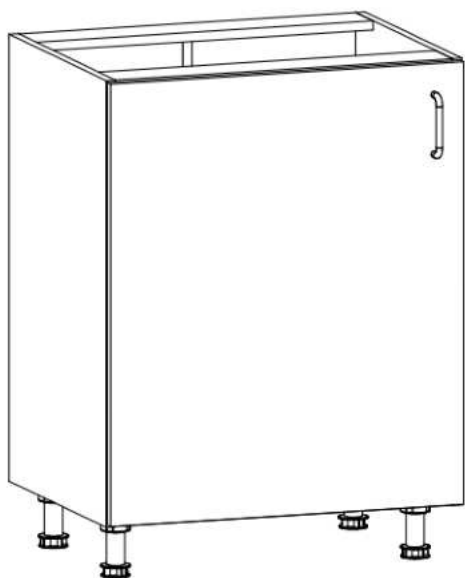

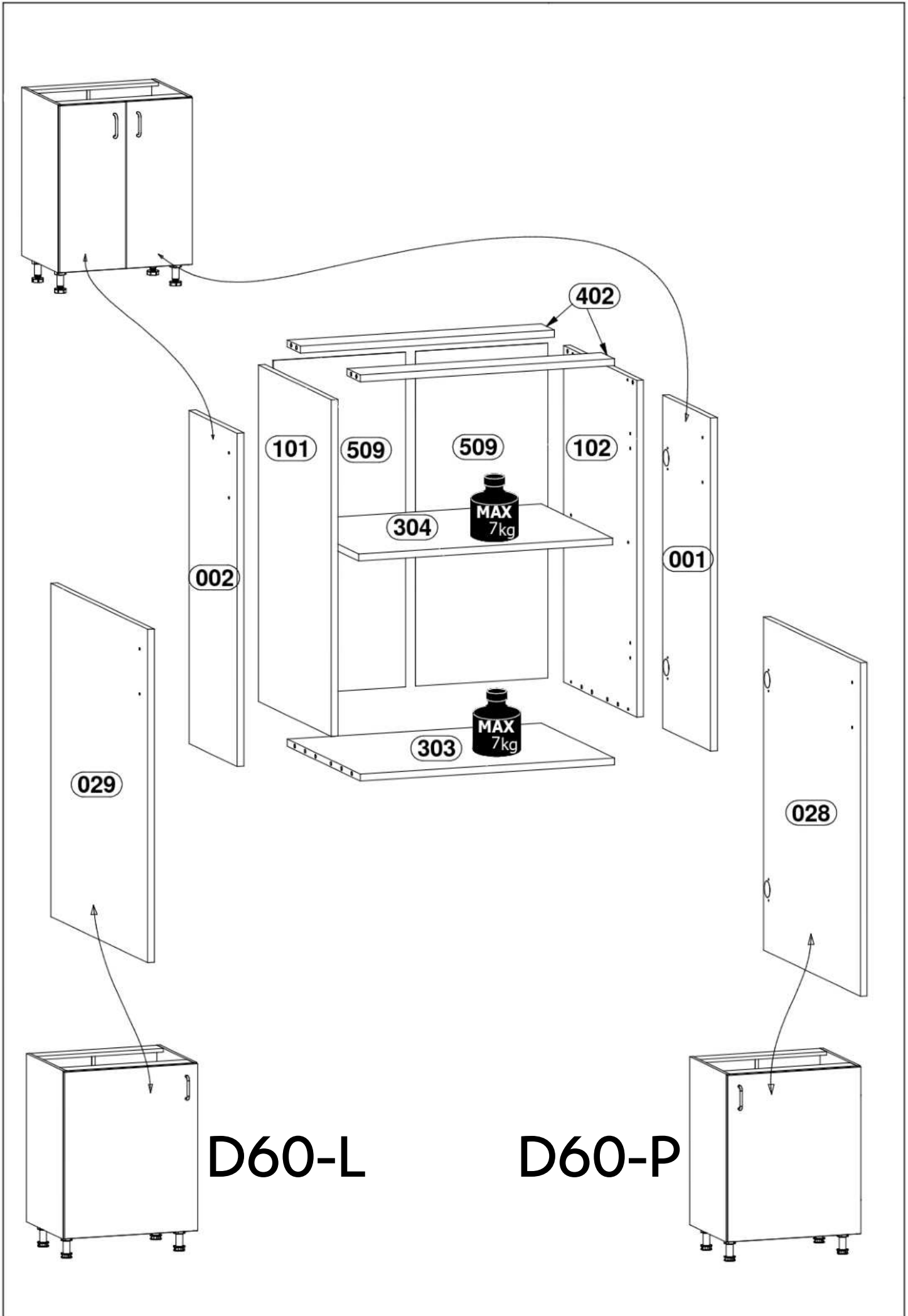



D60-L / D60-P

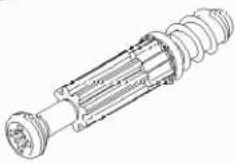

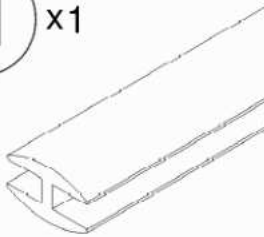
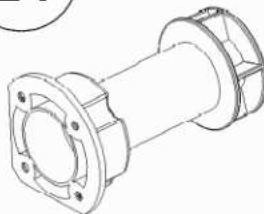

D60-L

D60-P

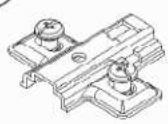
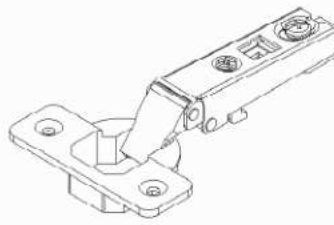
<p>A x12</p>  <p>Ø8x35mm</p>	<p>B x8</p> 	<p>C x8</p>  <p>Ø15x12mm</p>	<p>E x4</p> 
<p>G x27</p> 	<p>H x1</p>  <p>715 mm</p>	<p>L1 x4</p> 	<p>M x2</p> 
<p>W2 x24</p>  <p>Ø3,5x16mm</p>	<p>Y x8</p>  <p>Ø18 mm</p>	<p>Zc x4</p>  <p>Zc-1</p>	 <p>Zc-2</p>

1

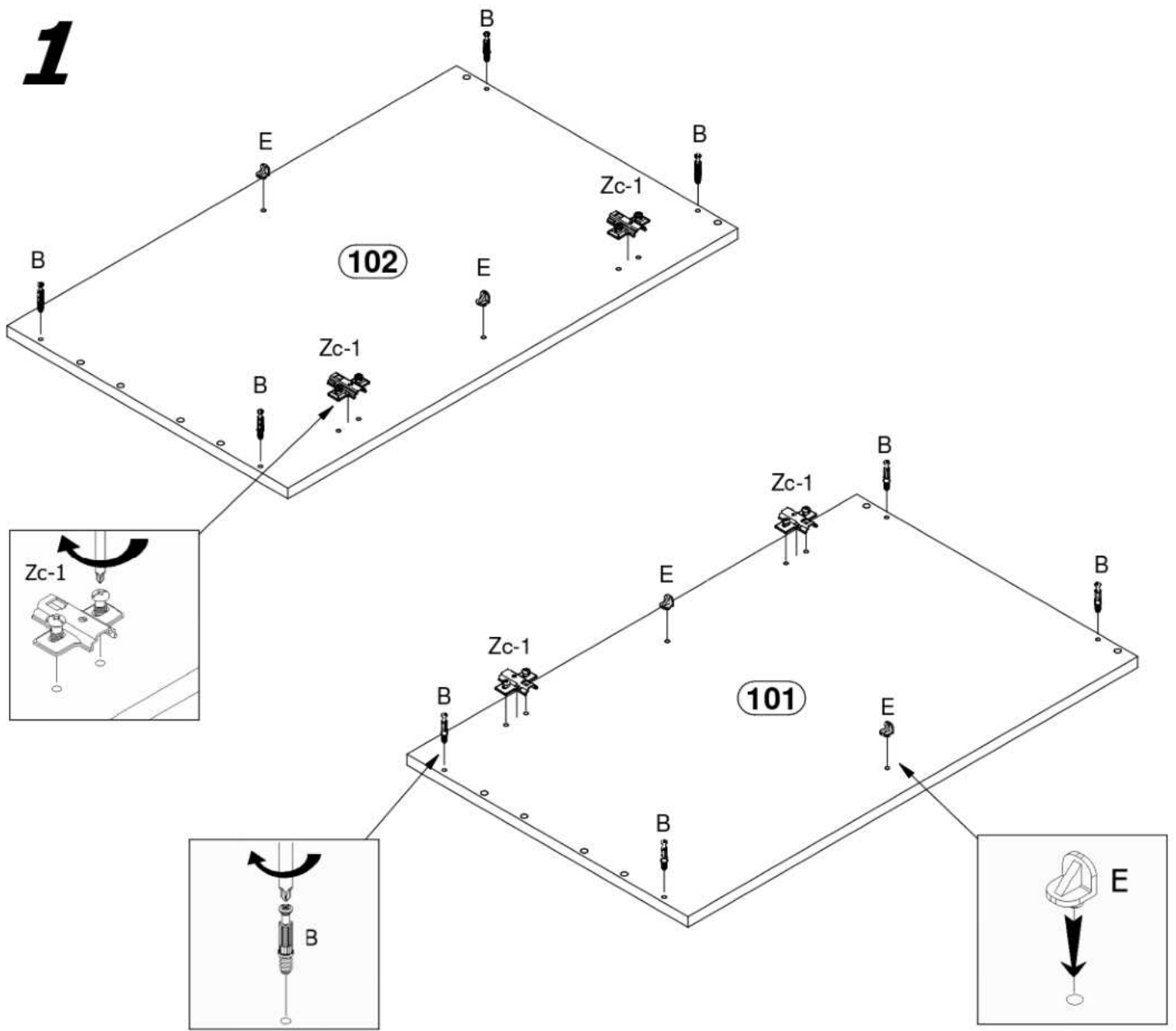

2

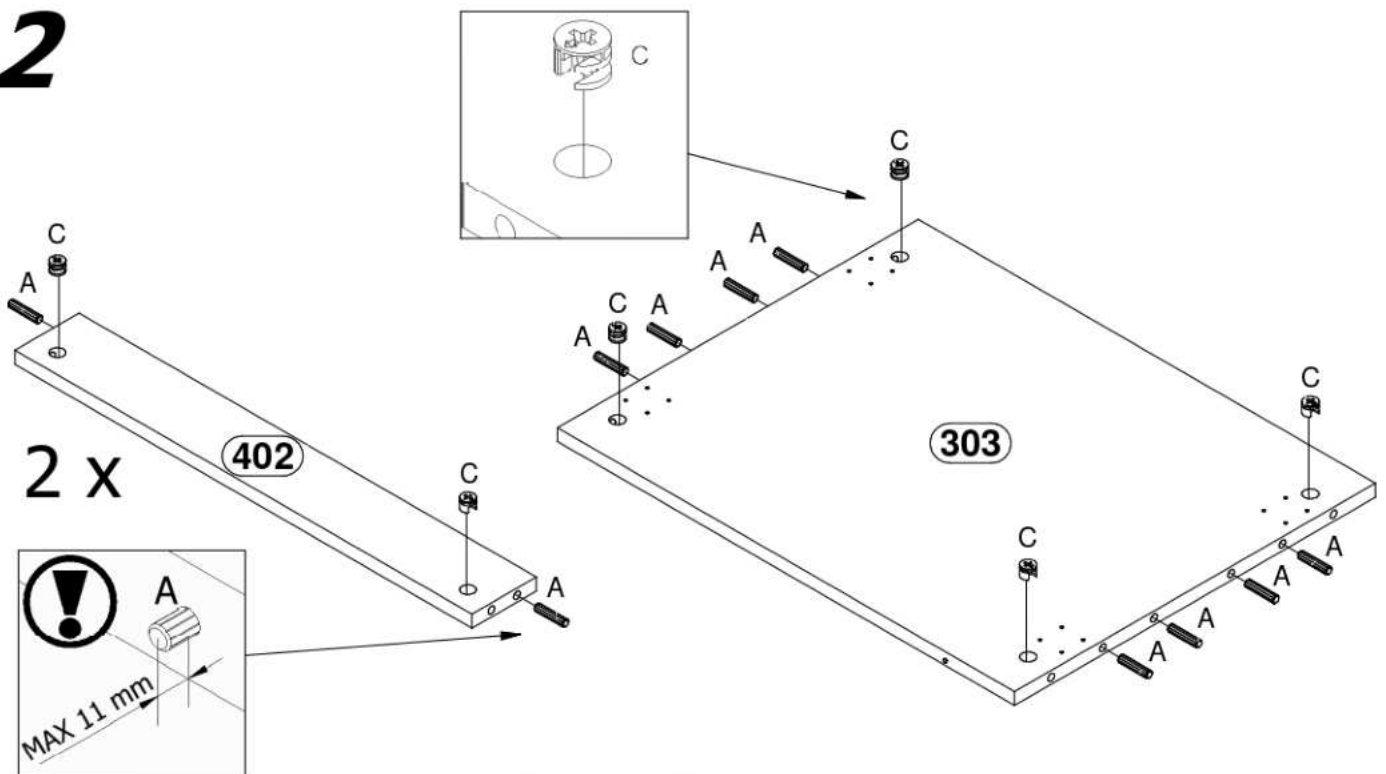

3

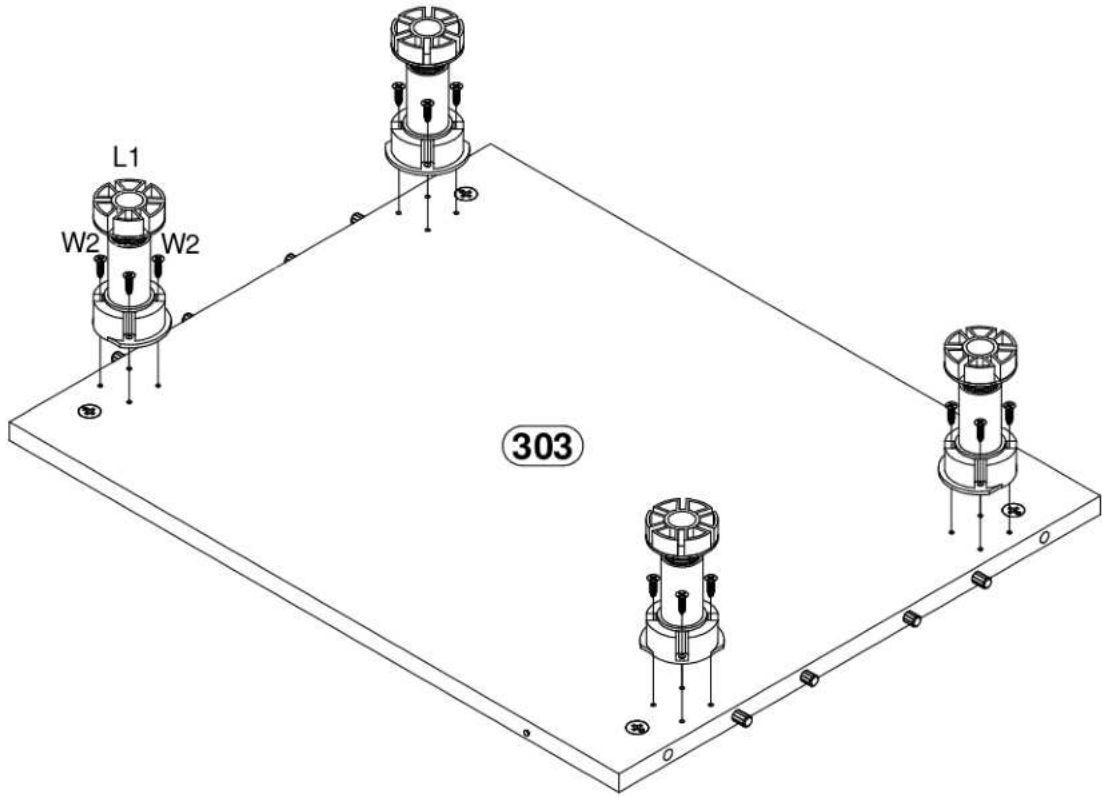

4

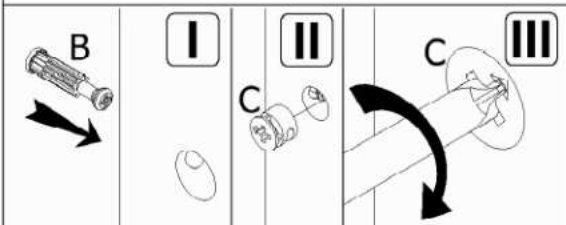
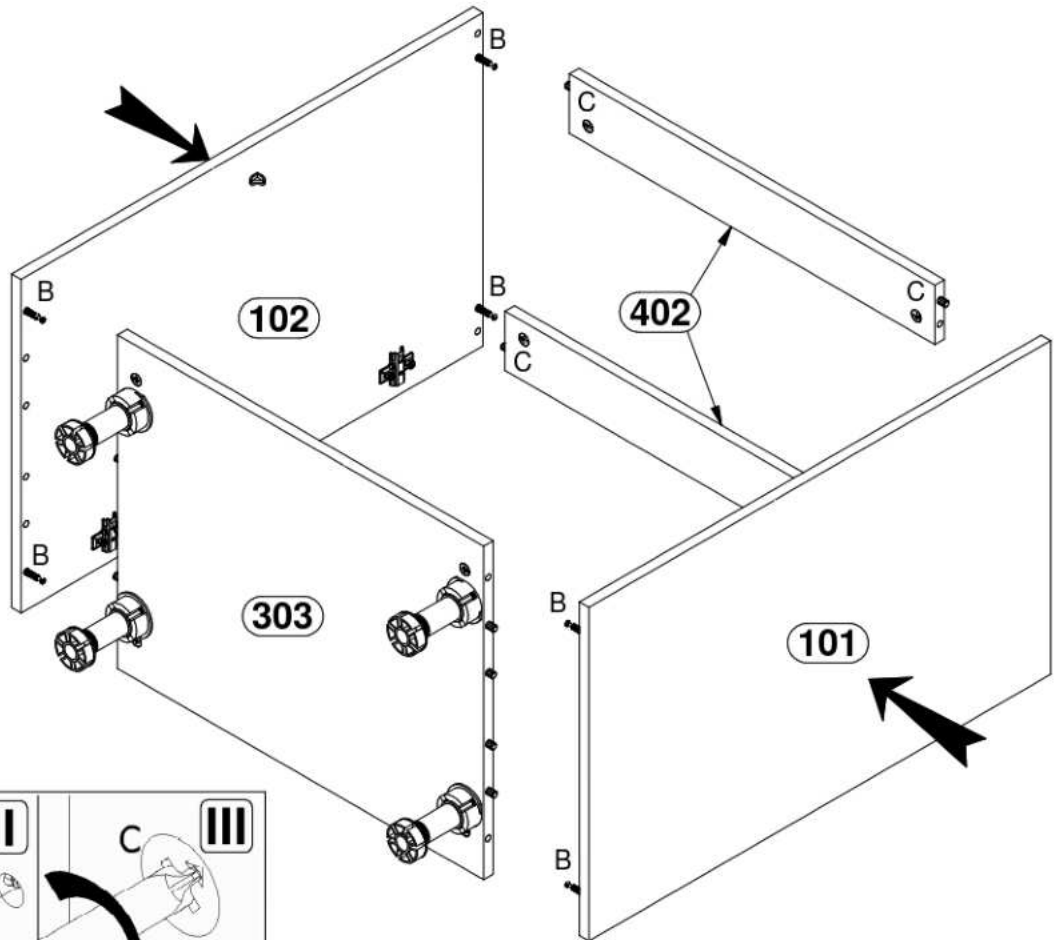

5

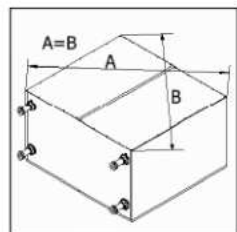
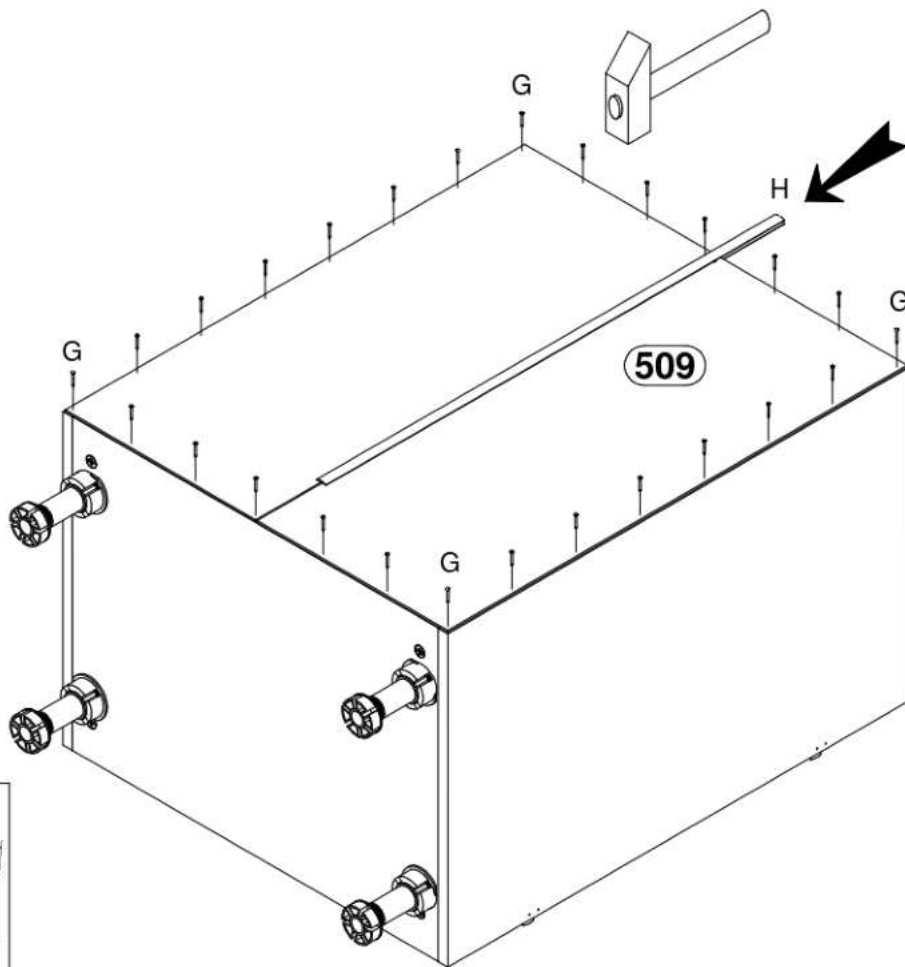

6

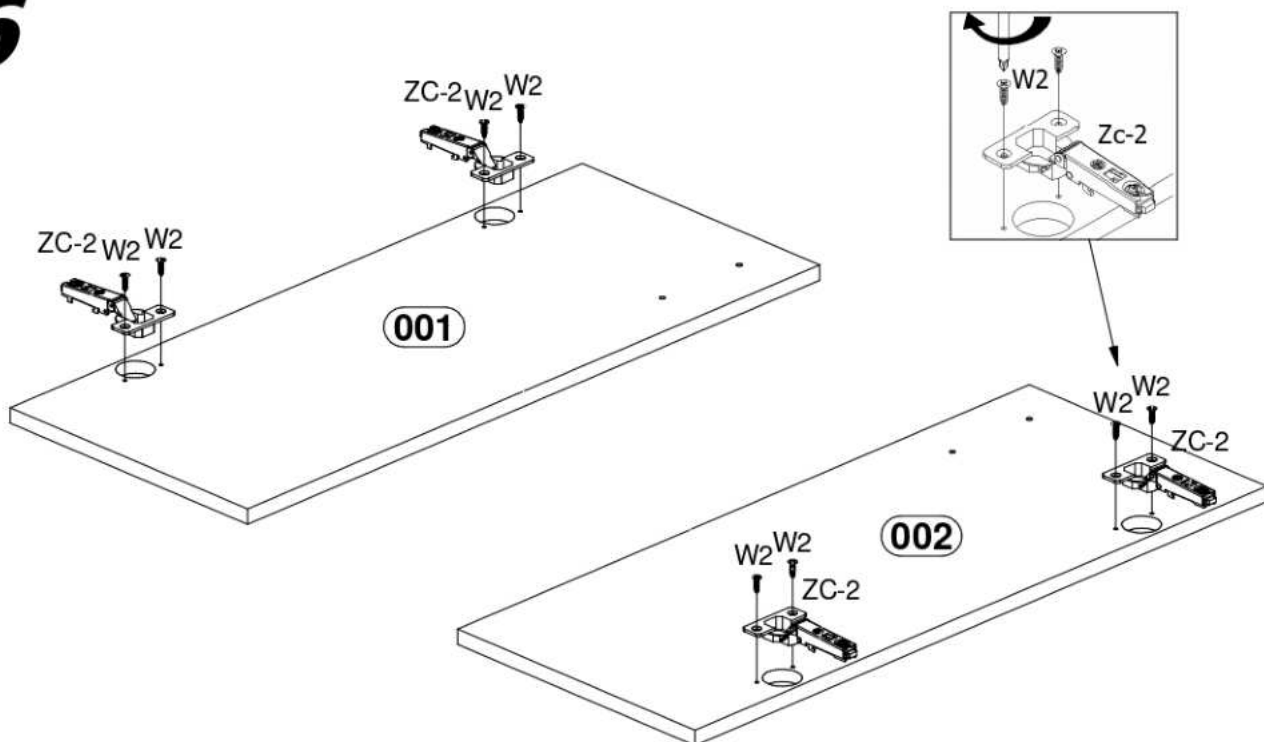

7

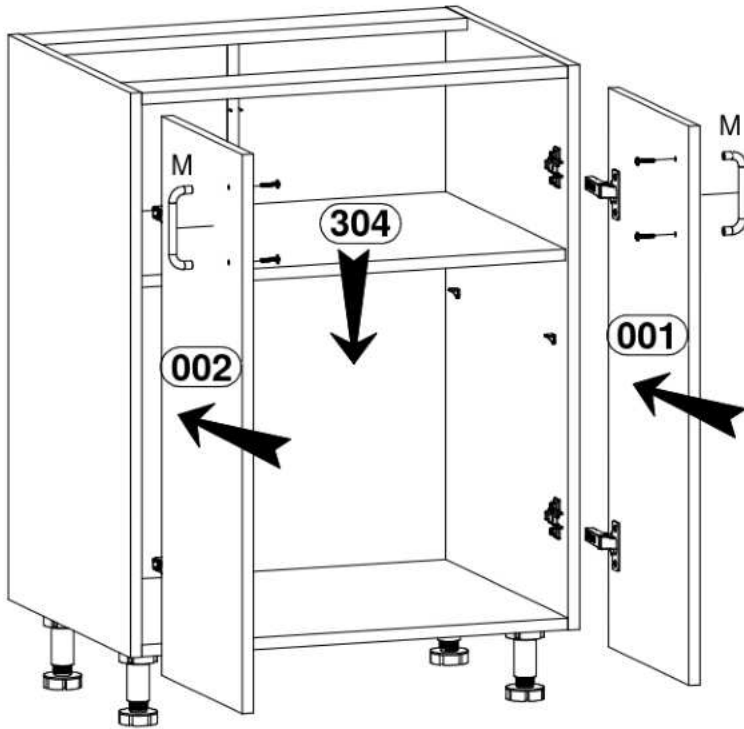

8

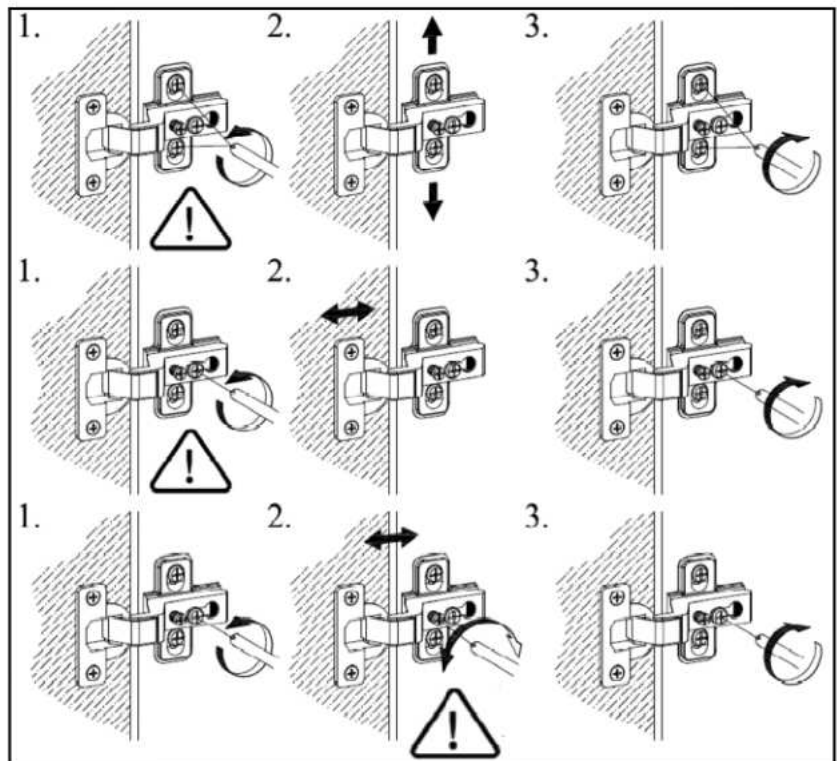

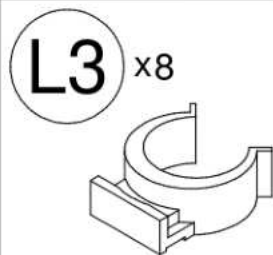
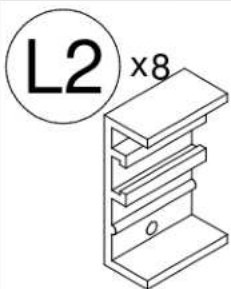
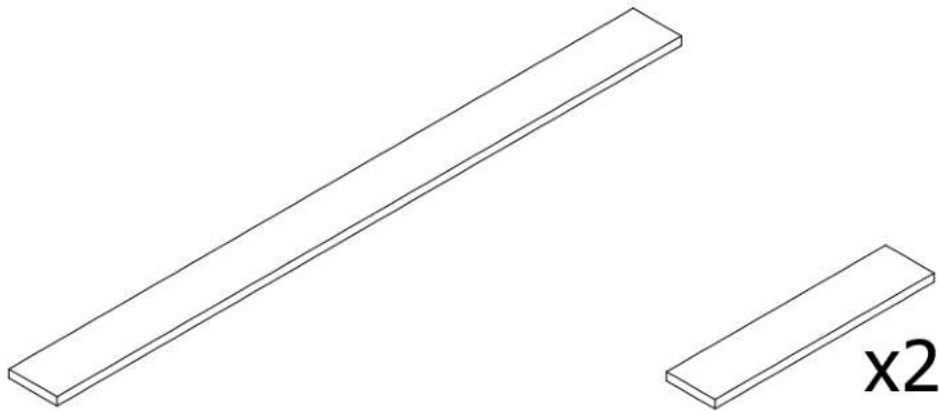
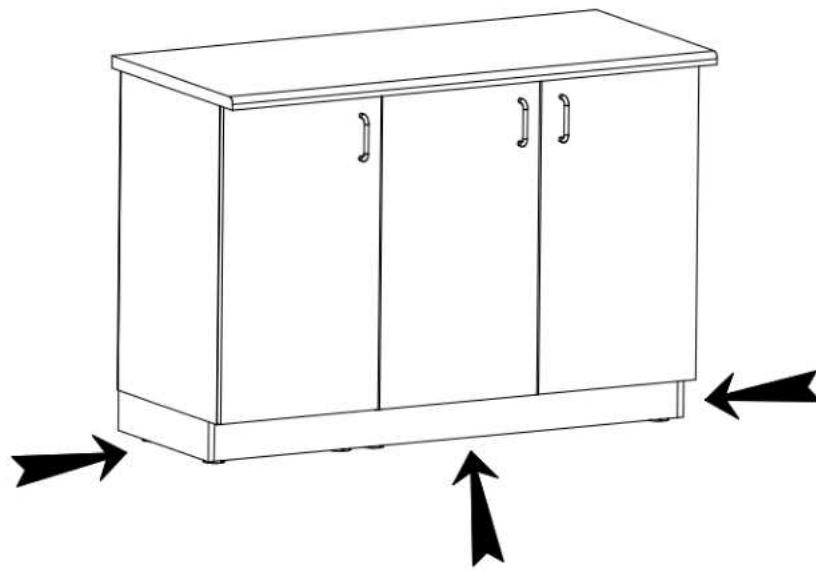

Ø3,5x16

9

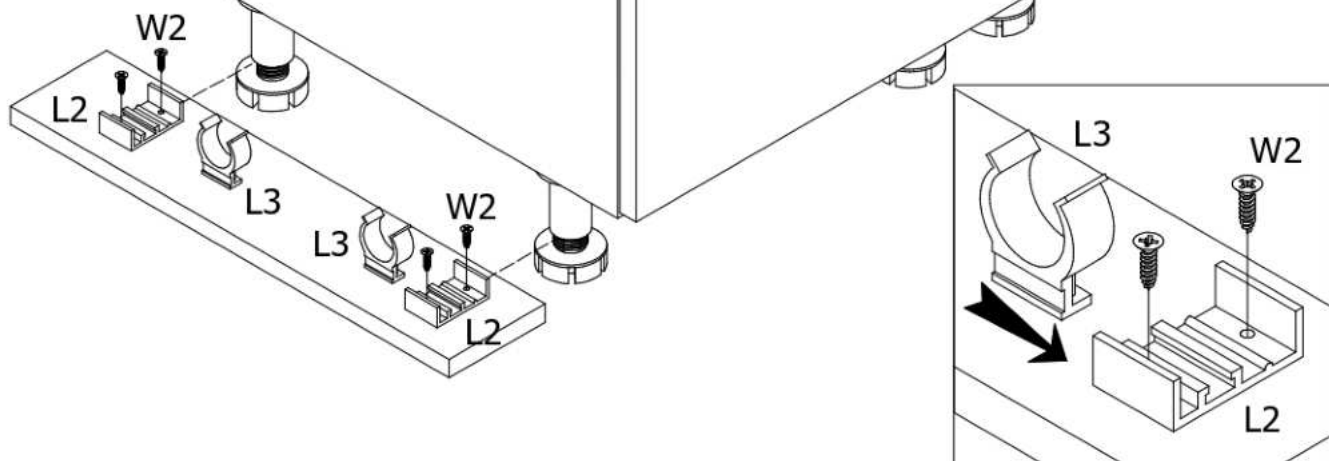

10

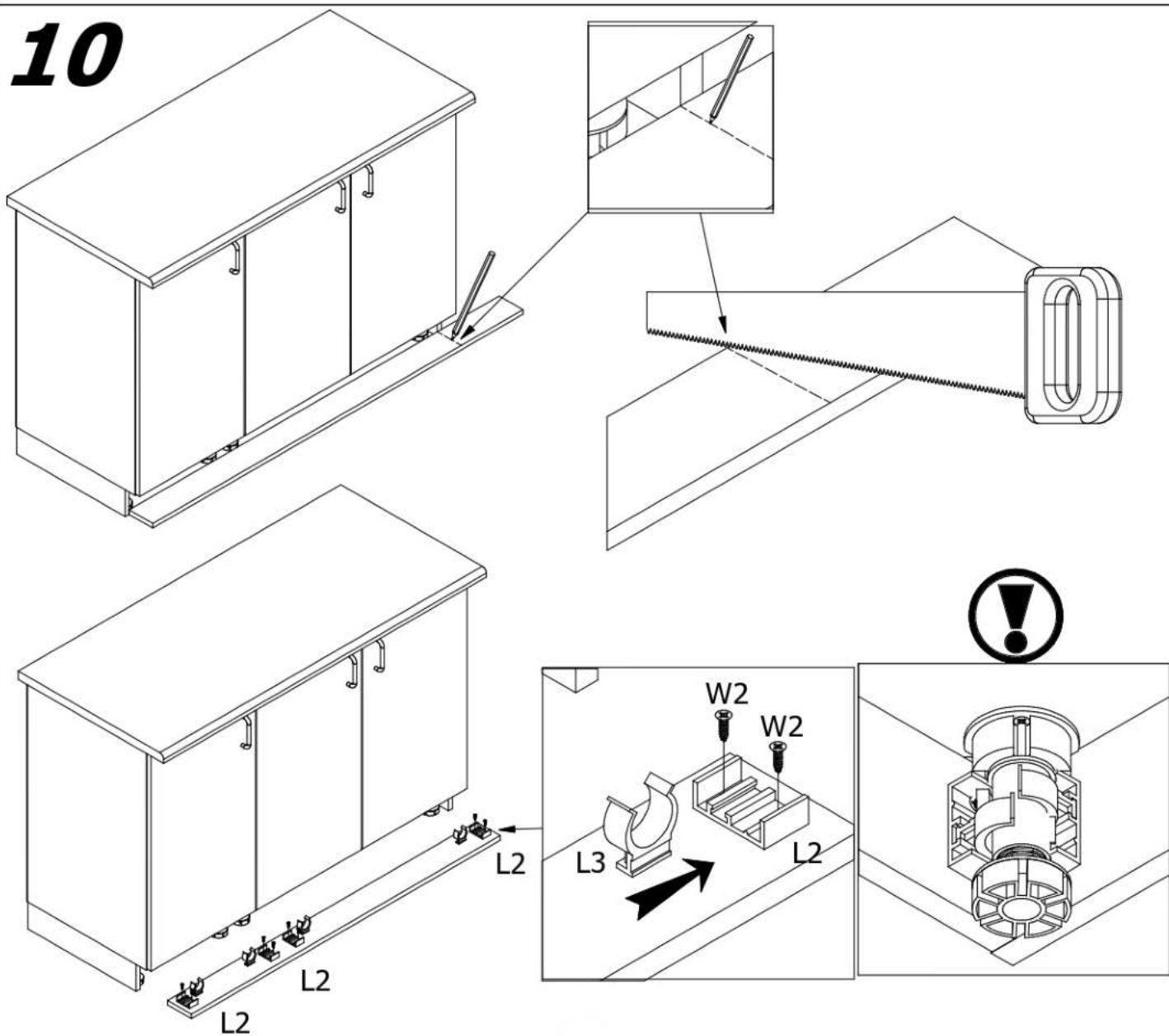

AURORA

D60P

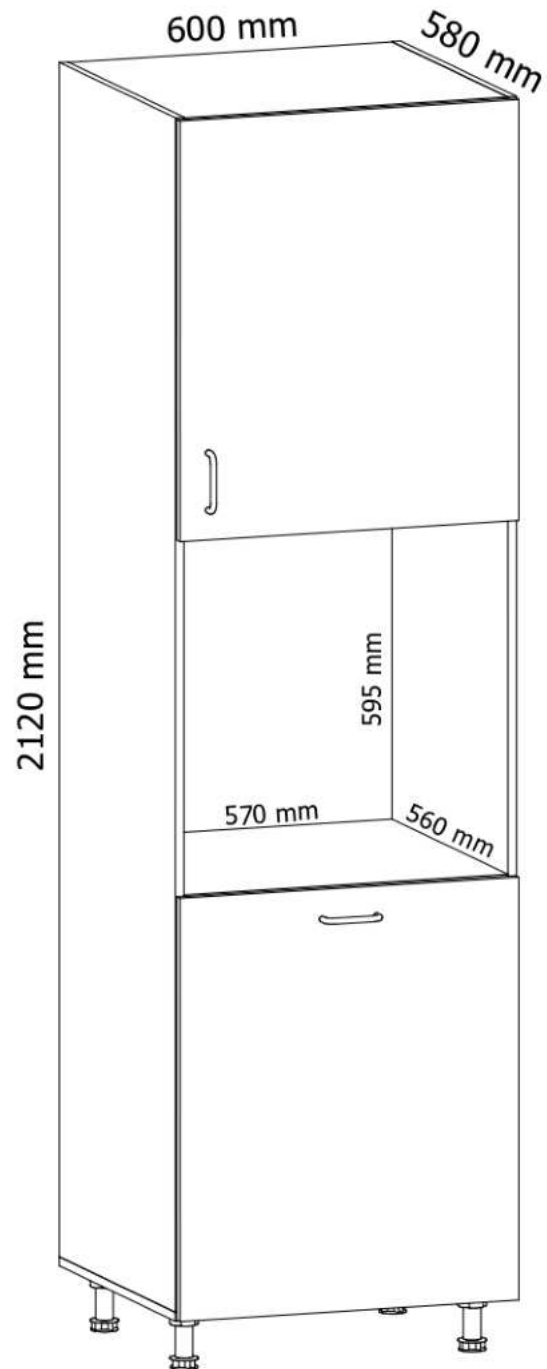

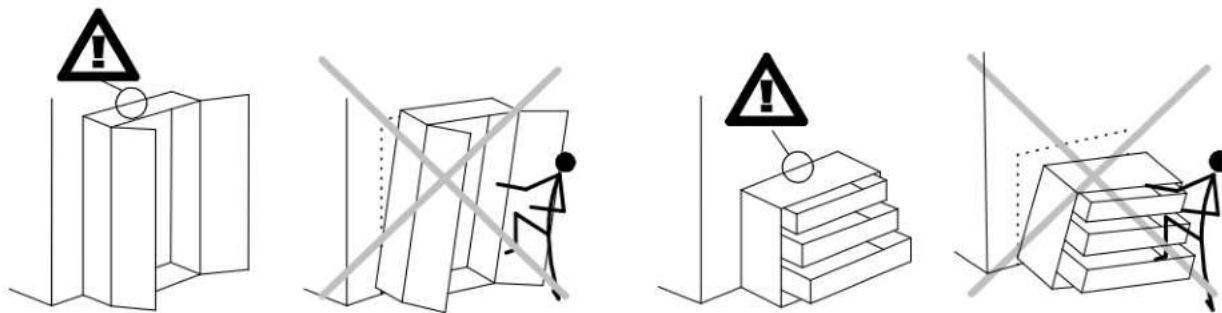

SK:

VÝSTRAHA PRED PREVRÁTENÍM!

Tento produkt musí byť natrvalo pripevnený k stene pomocou dodanej(-ých) konzoly (konzol), aby sa predišlo smrteľnému úrazu v prípade, že sa prevráti.

Balenie obsahuje iba skrutky, ktorými sa pripevňujú k produktu samotné konzoly chrániace pred prevrátaním. Kontaktujte miestnu predajňu pre domácich majstrov alebo železiarstvo, kde vám poradia ohľadom správneho typu skrutiek/príchytiiek pre váš typ steny.

CZ:

VAROVÁNÍ TÝKAJÍCÍ SE SKLOPENÍ!

Tento výrobek musí být trvale připevněn na stěnu pomocí přiložených držáků, aby nedošlo ke smrtelnému zranění, kdyby se sklopil. Sada obsahuje pouze šroubky pro upevnění držáků zabraňujících sklopení k výrobku. Ohledně správného typu vrutů/hmoždinek pro daný typ stěny se obraťte na vhodný obchod nebo železářství.

HR:

UPOZORENJE O OPASNOSTI OD PADA!

Ovaj proizvod mora stalno da bude pričvršćen za zid držačem (držačima) iz pakovanja, da bi se izbegla smrtonosna povreda u slučaju da proizvod padne.

Pakovanje sadrži samo šrafove za pričvršćavanje na proizvod držača protiv padanja. Kontaktirajte prodavnicu "Uradi sam" ili gvoždarsku radnju za savet o ispravnoj vrsti šrafova/tiplova za tip zida koji imate.

RO:

ATENȚIONATE RISC RĂSTURNARE!

Acest produs trebuie să fie atașat permanent de perete folosind suportului(rilor) furnizat(e) pentru a preveni rănirea mortală în cazul în care se răstoarnă.

Pachetul conține doar șuruburi, care sunt folosite pentru a atașa suporturile anti-răsturnare de produs. Contactați magazinul local de bricolaj sau magazinul de fierărie pentru sfaturi despre tipul corect de șuruburi/dibluri pentru tipul dumneavoastră de perete.

SI:

OPOZORILO PRED PREVRNITVIJO!

Ta izdelek mora biti trajno pritrjen na steno s pomočjo priloženih nosilcev, da se preprečijo smrtne poškodbe v primeru prevrnitve.

Paket vsebuje samo vijake, s katerimi se na izdelek pritrdijo sami nosilci za zaščito pred prevrnitvijo. Za nasvet o pravilni vrsti vijakov/vijakov za vaš tip stene se obrnite na lokalno trgovino z gradbenimi pripomočki.

HU:

FELBORULÁSRA VONATKOZÓ FIGYELMEZTETÉS!

Ezt a terméket tartósan a falhoz kell rögzíteni a mellékelt konzol(ok) segítségével, hogy elkerülje a halálos sérülést felborulás esetén.

A csomag csak csavarokat tartalmaz, amelyekkel a borulásgátló konzolokat rögzítik a termékhez. Forduljon a helyi lakberendezési bolthoz vagy hardverbolthoz, hogy tanácsot kapjon az Ön faltípusának megfelelő csavarok/kapcsok típusával kapcsolatban.

D60P

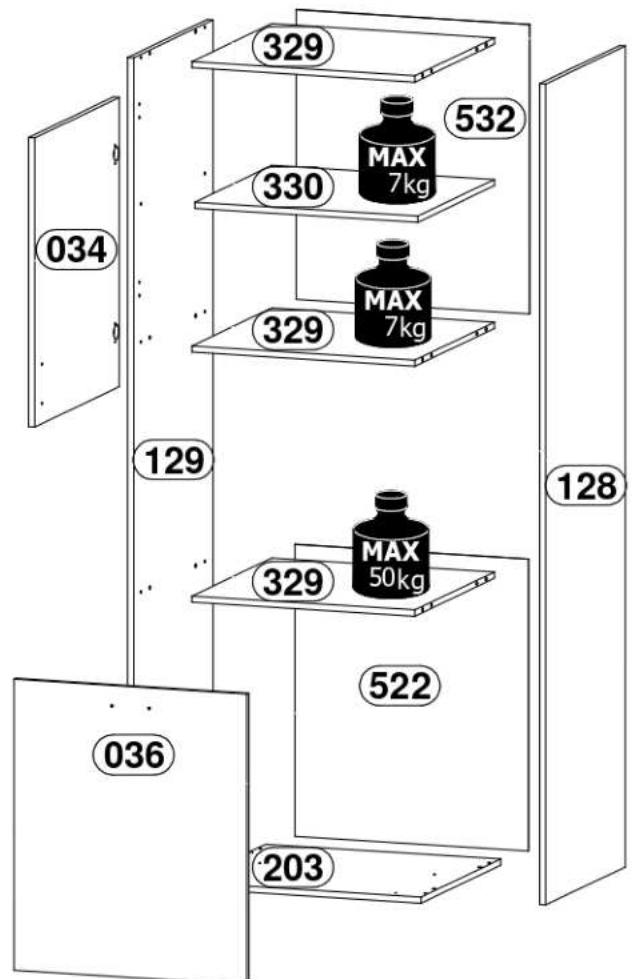
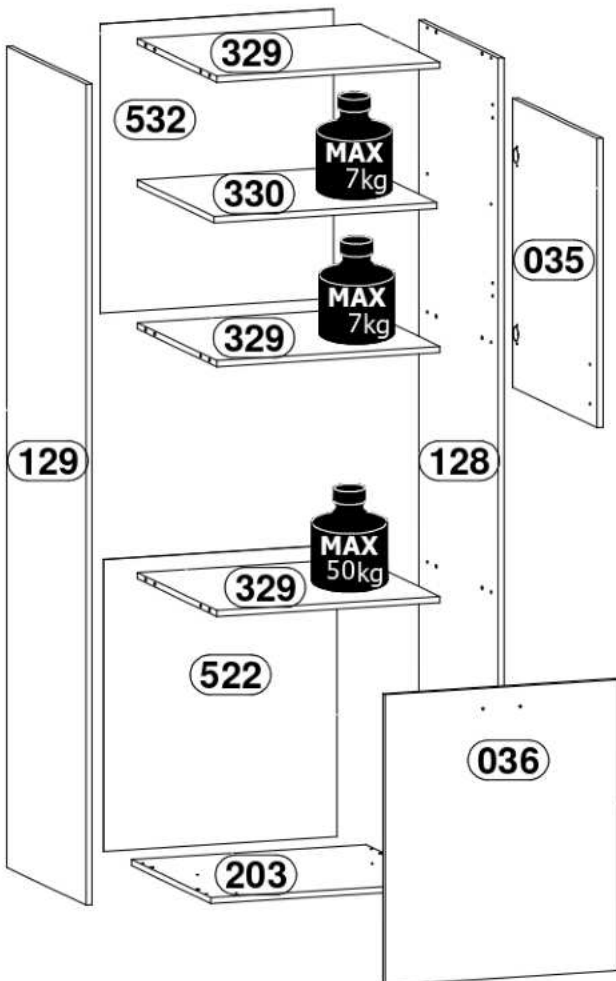
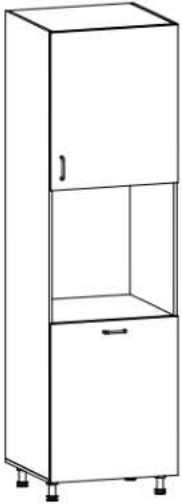

1

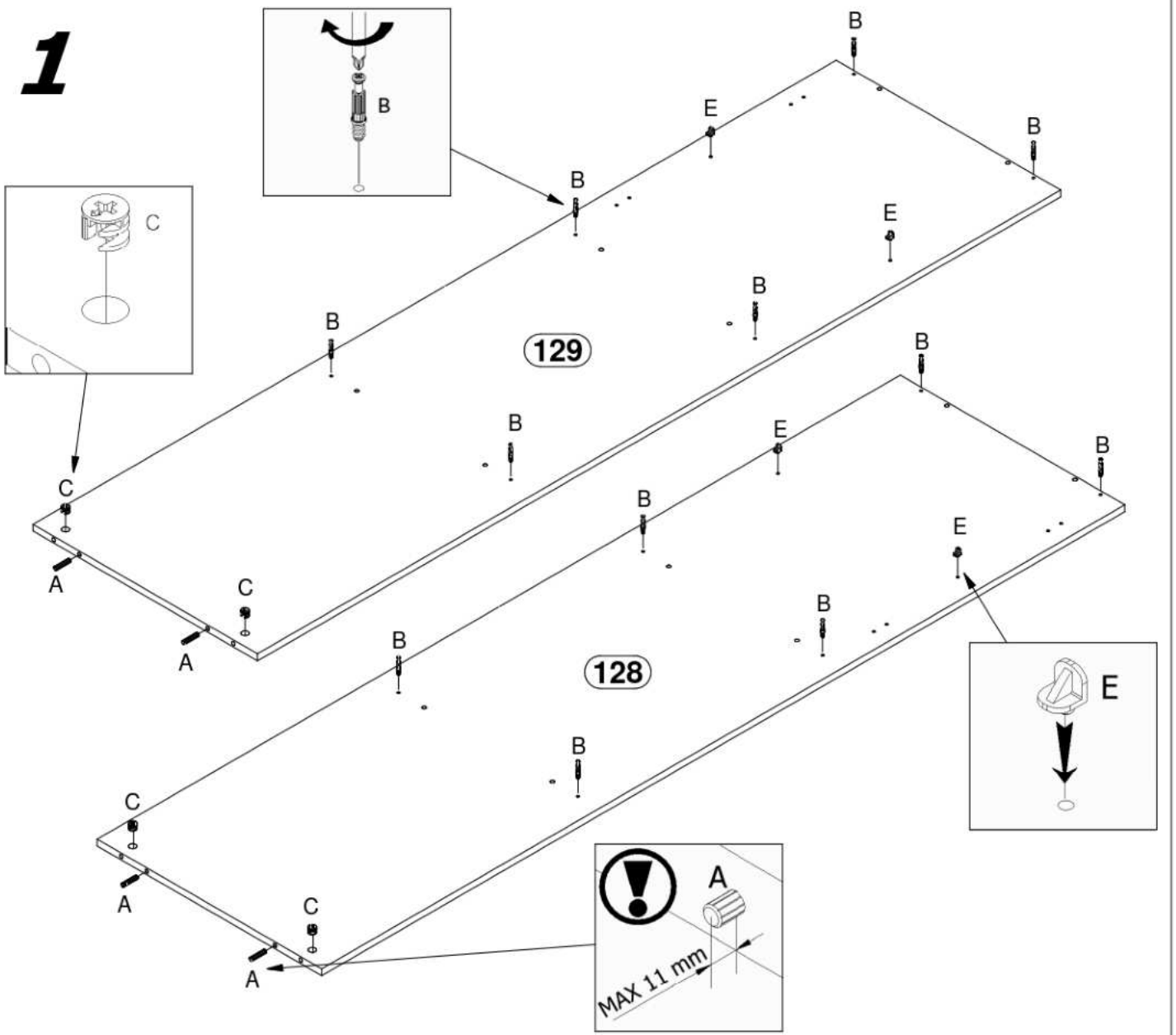

2

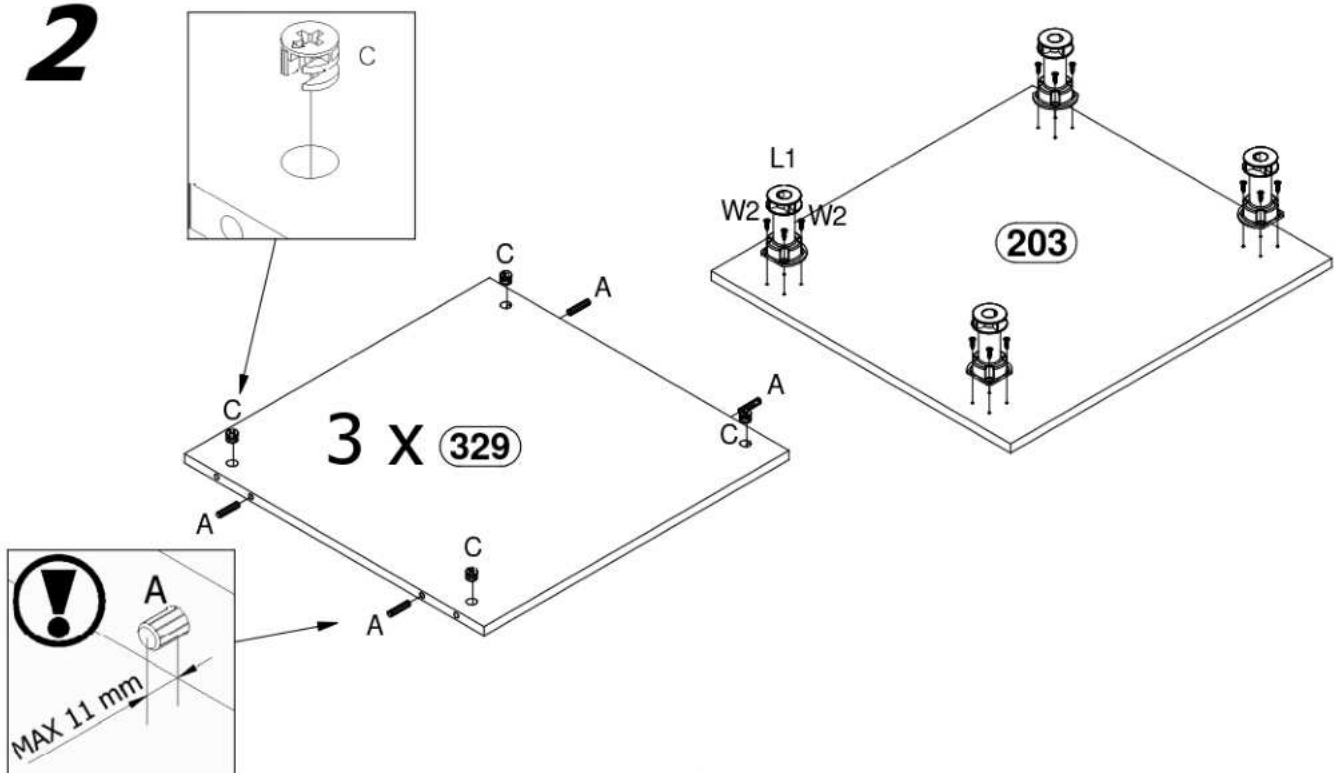

3

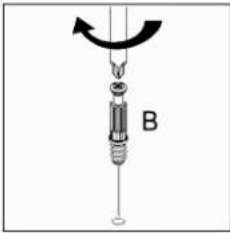
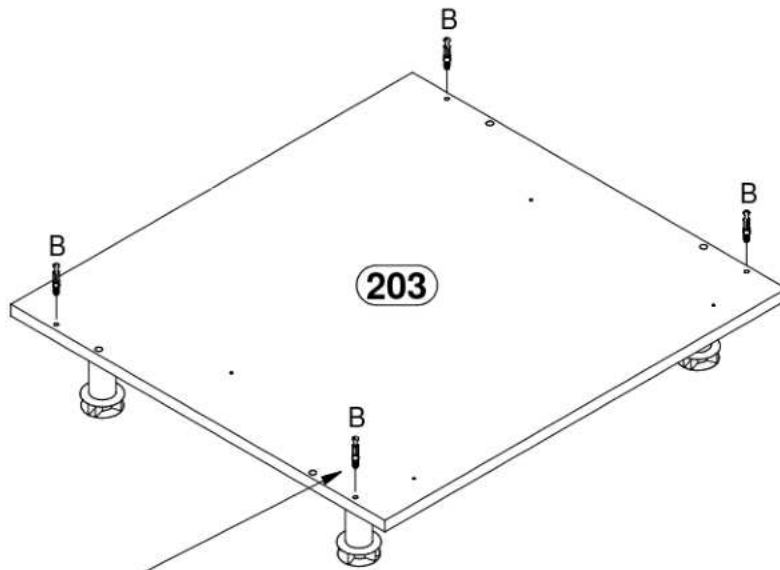

4

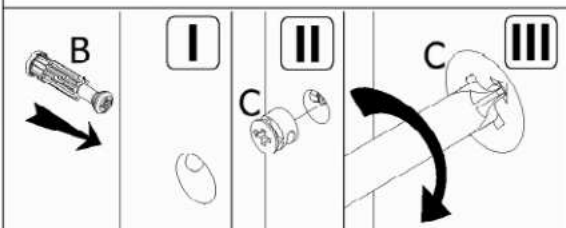
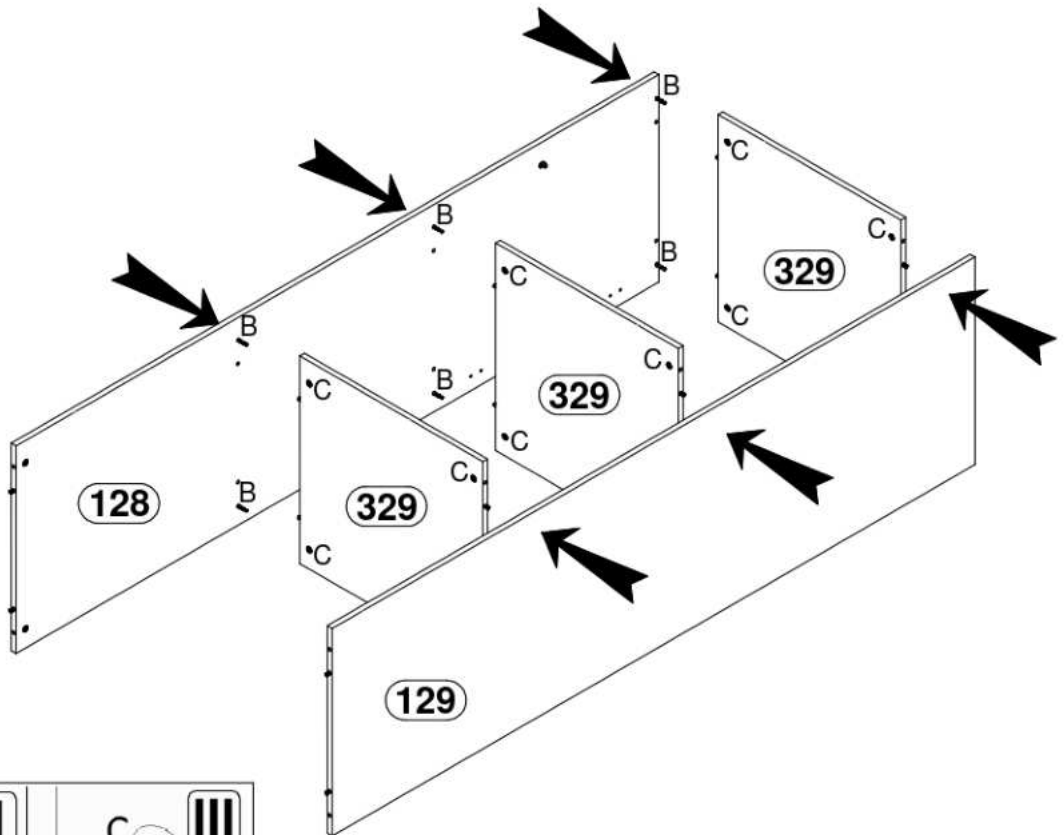

5

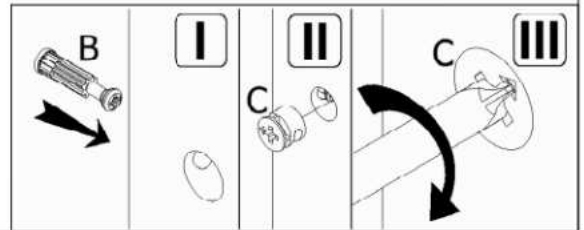
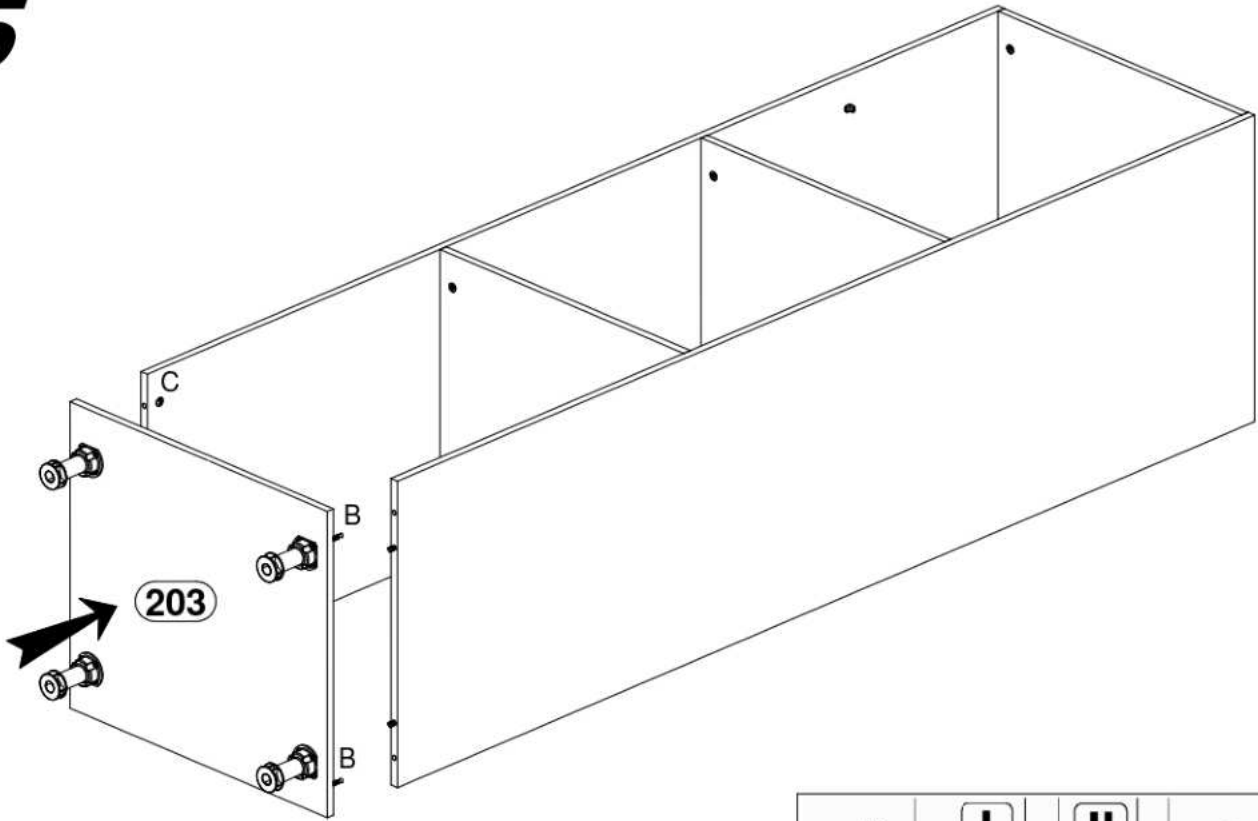

6

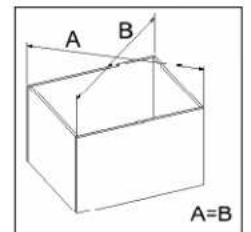
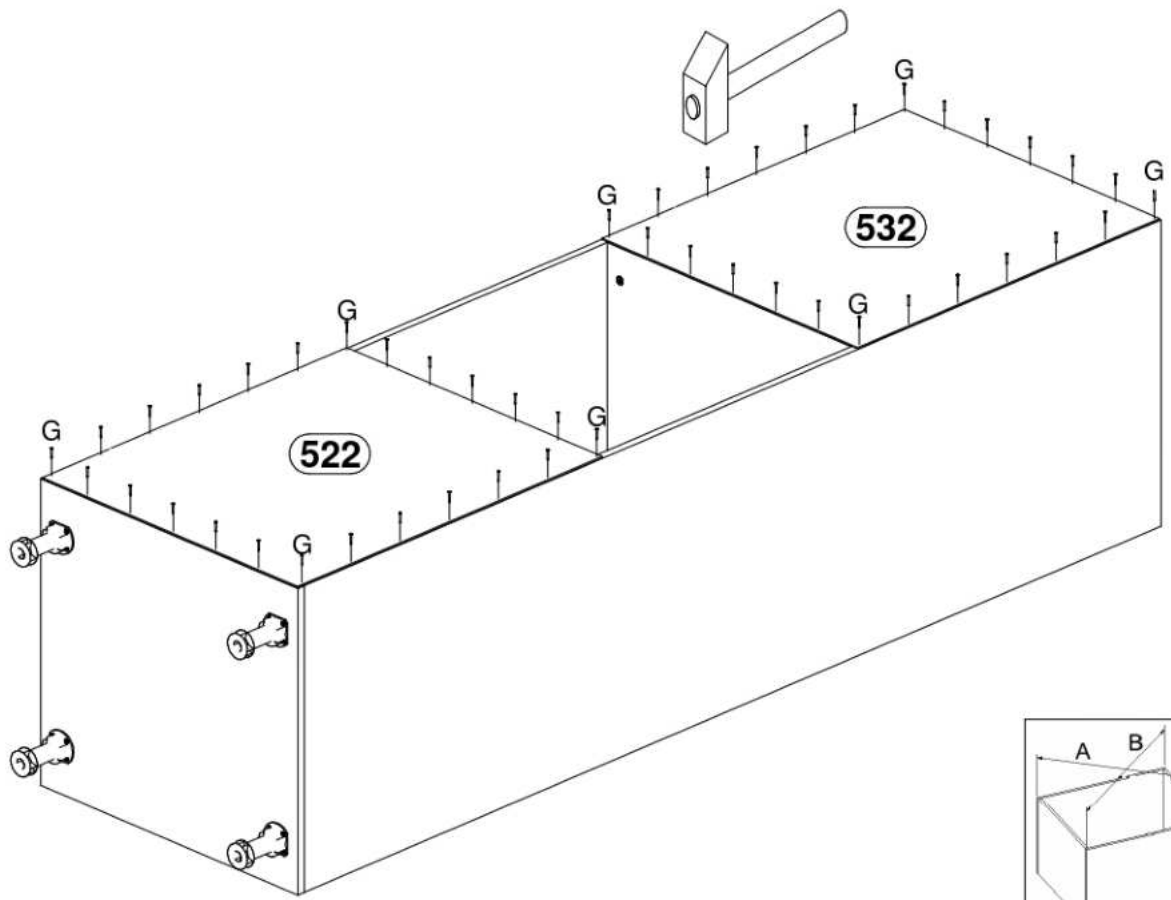

7

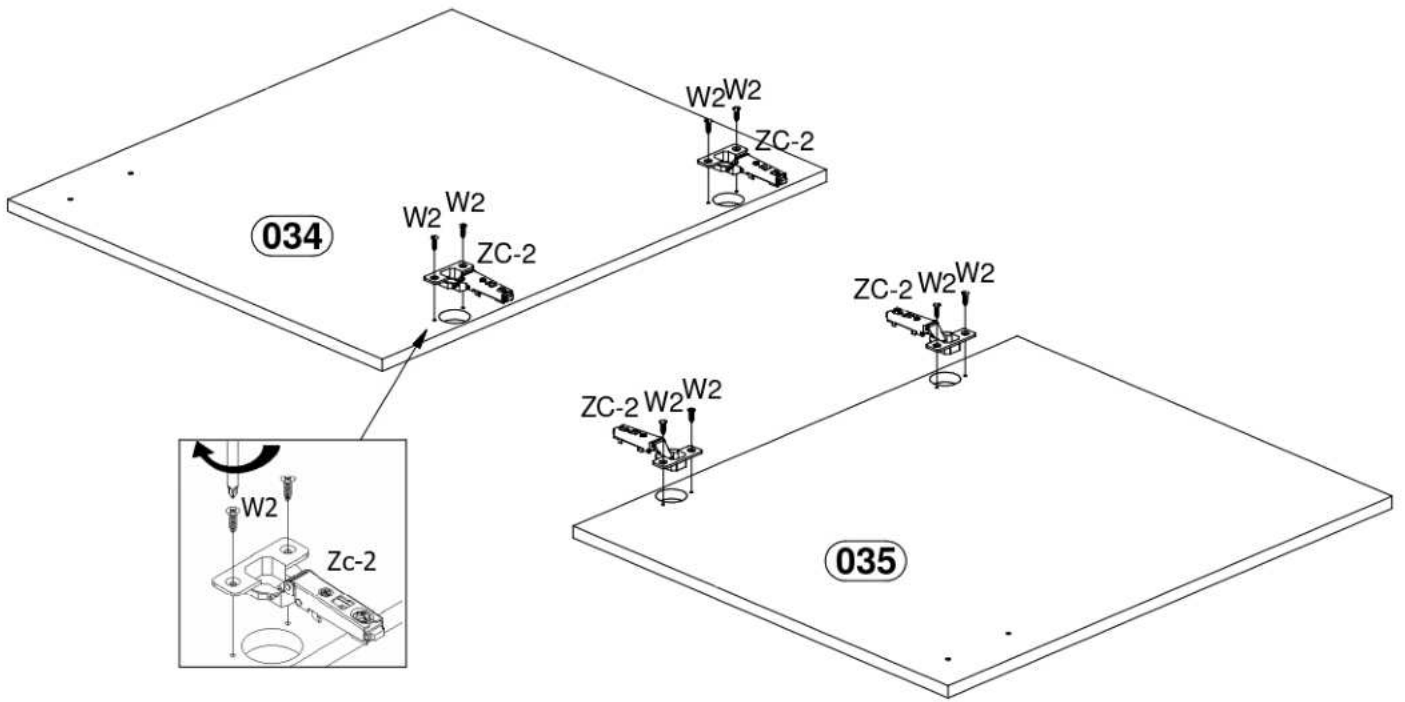

8

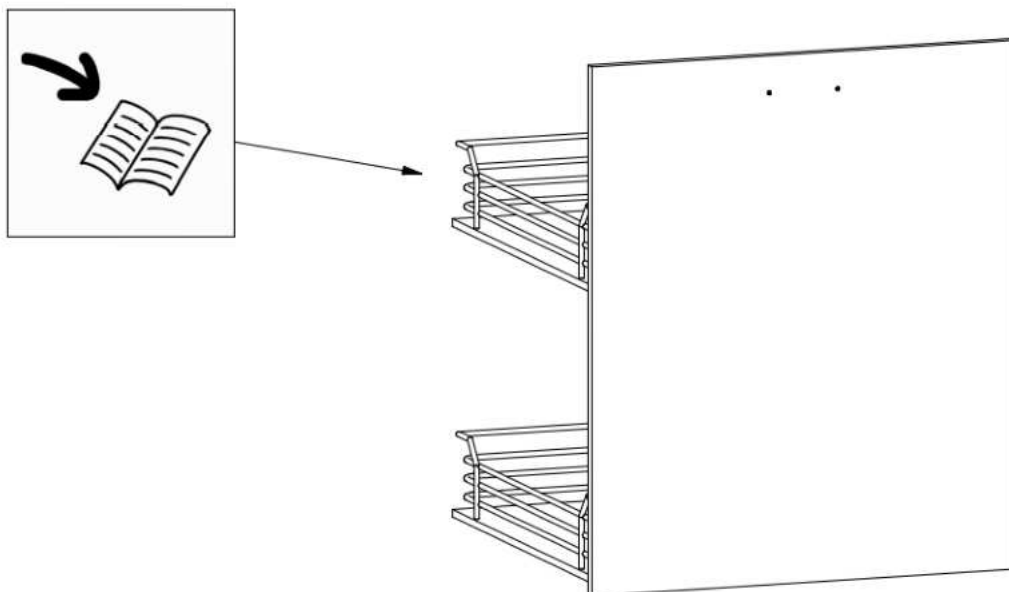

9

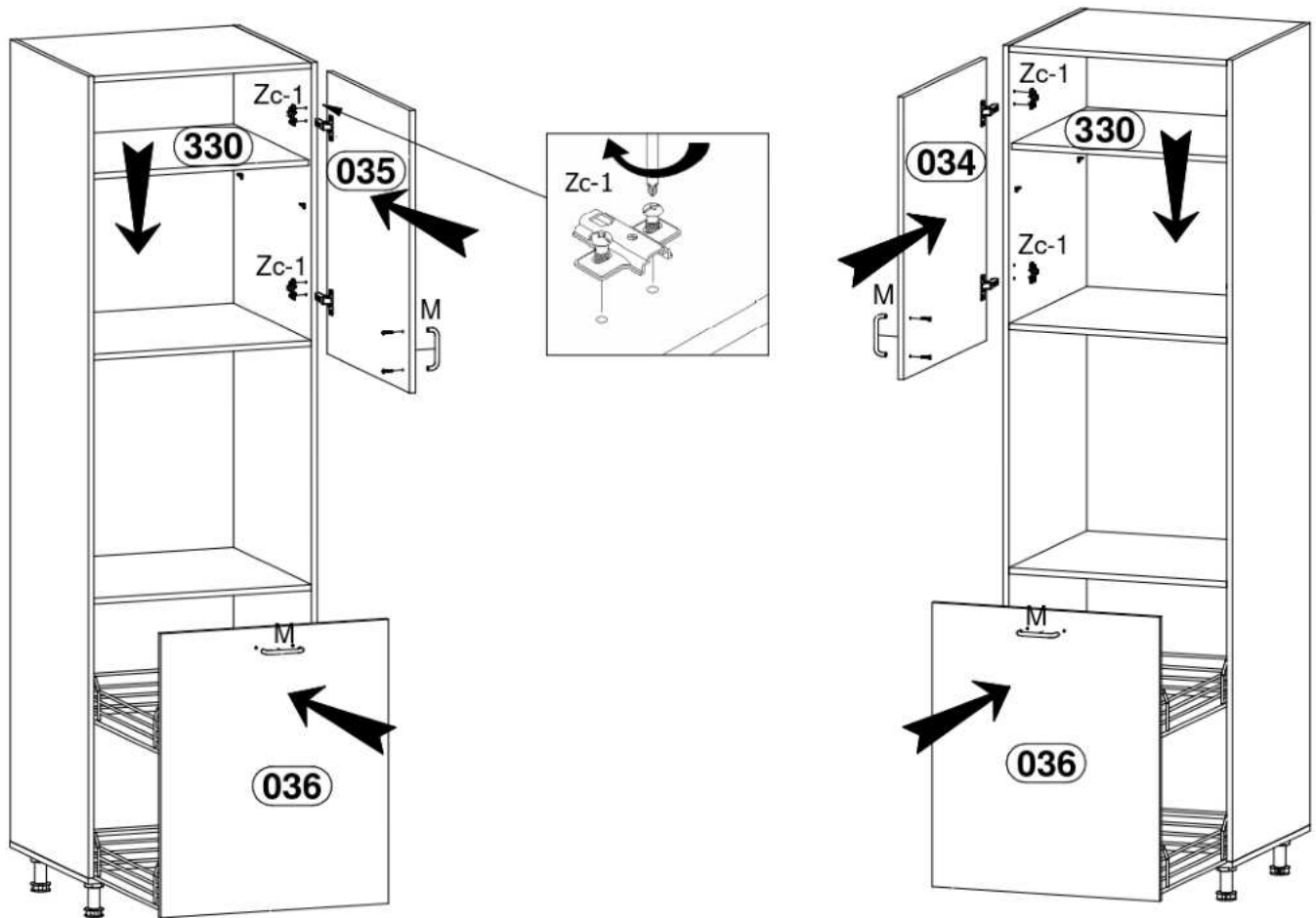

10

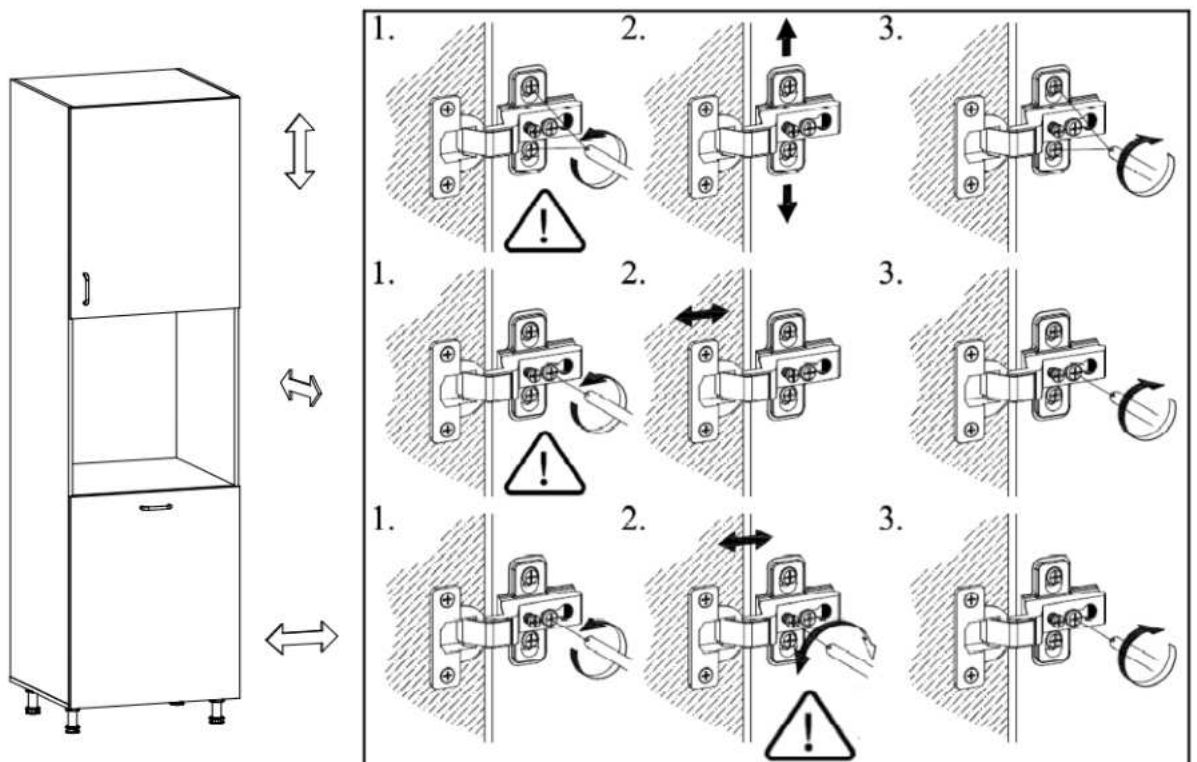

11

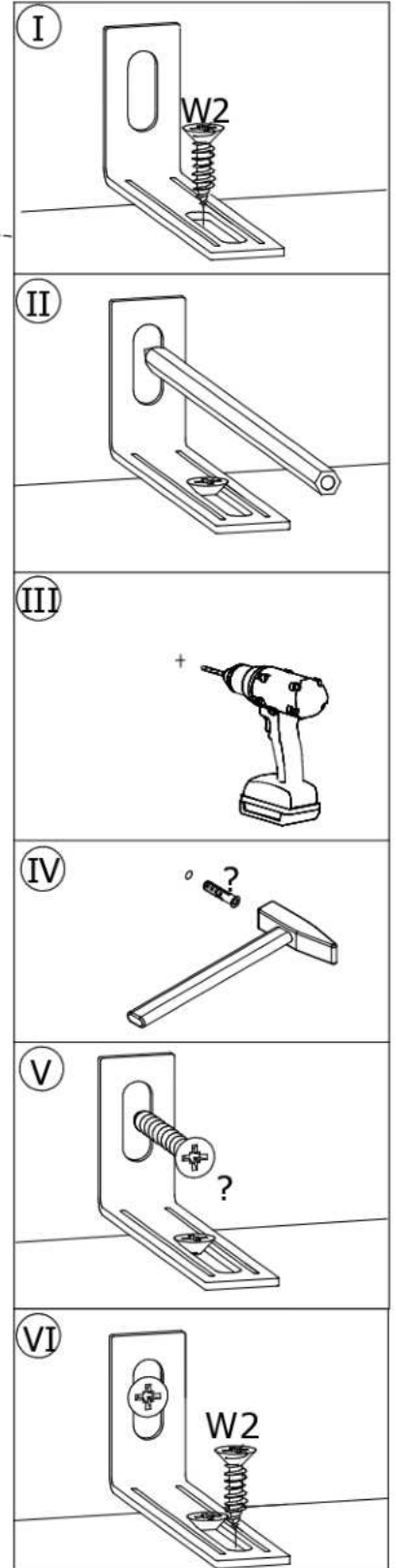
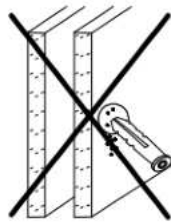
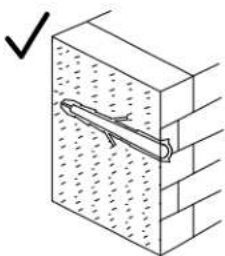
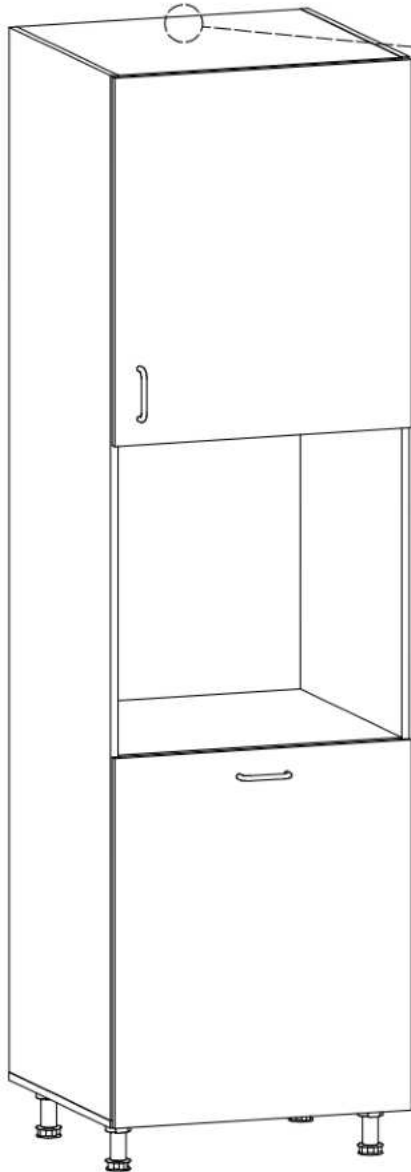
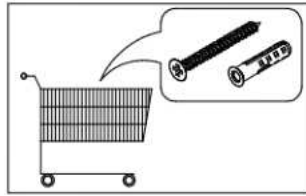
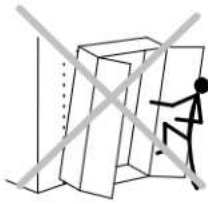
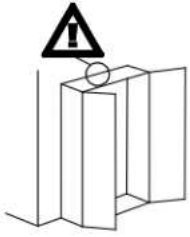

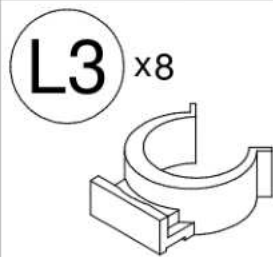
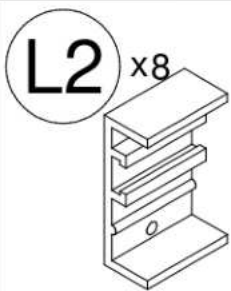
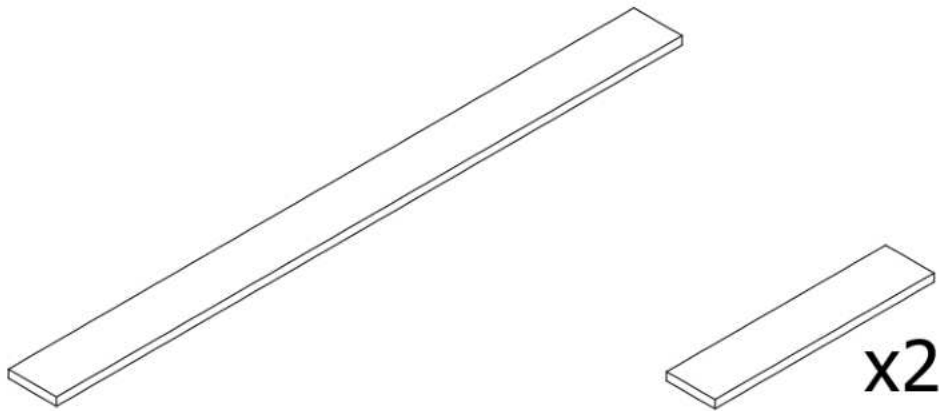
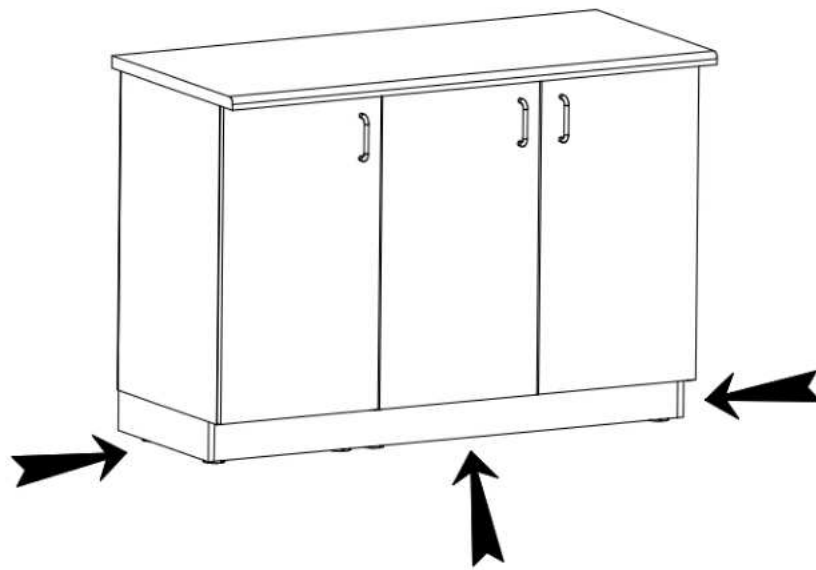

Ø3,5x16

12

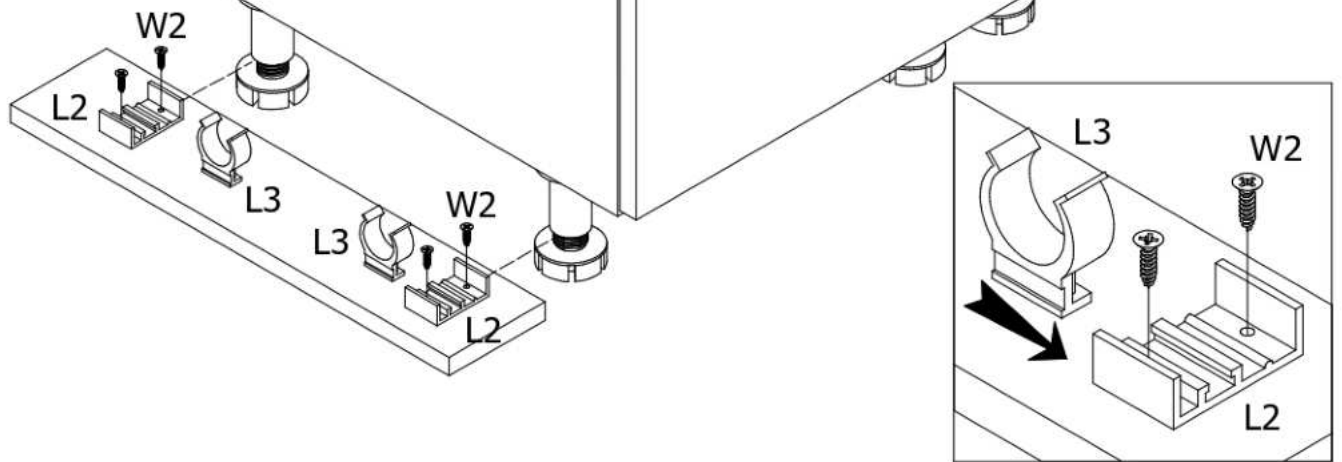

13

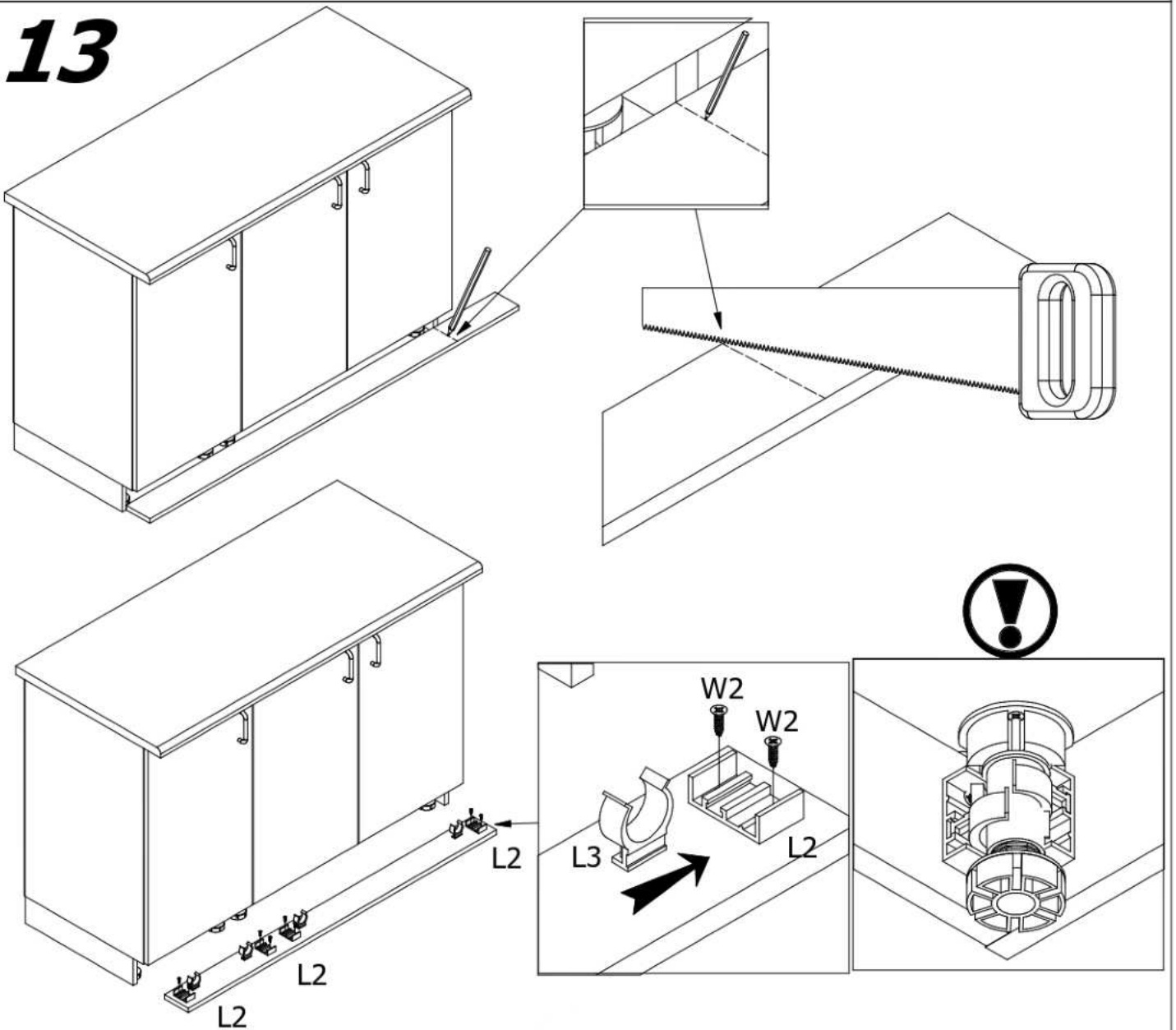

AURORA

D60R

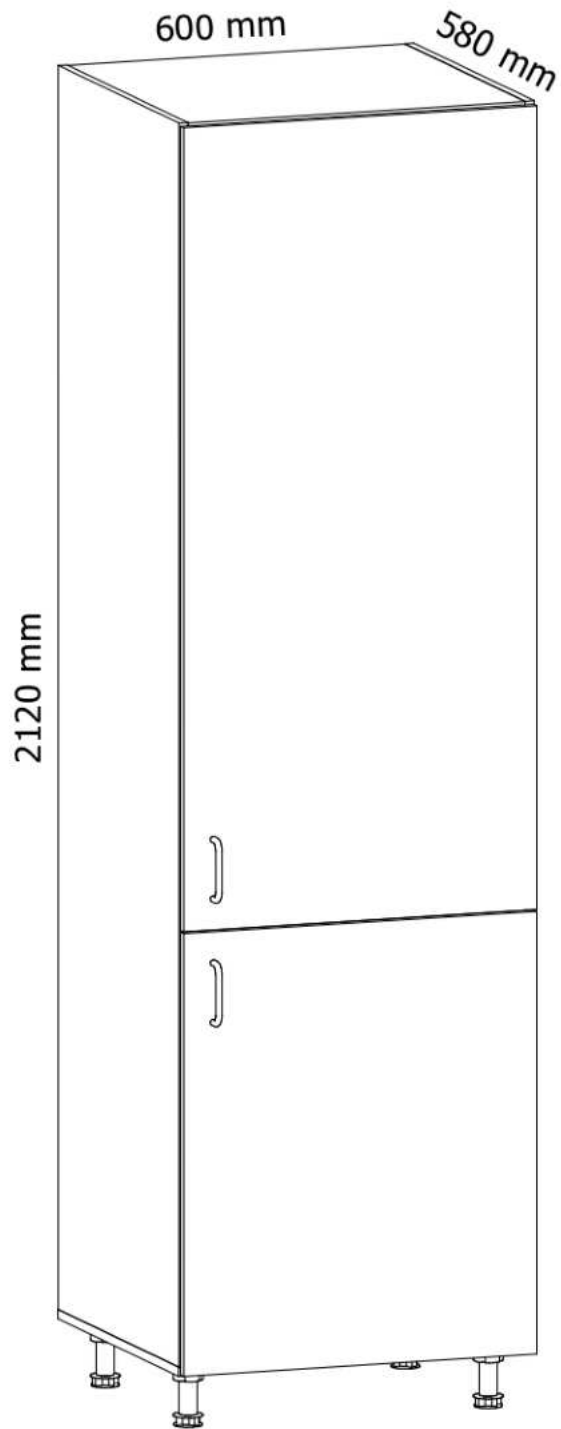

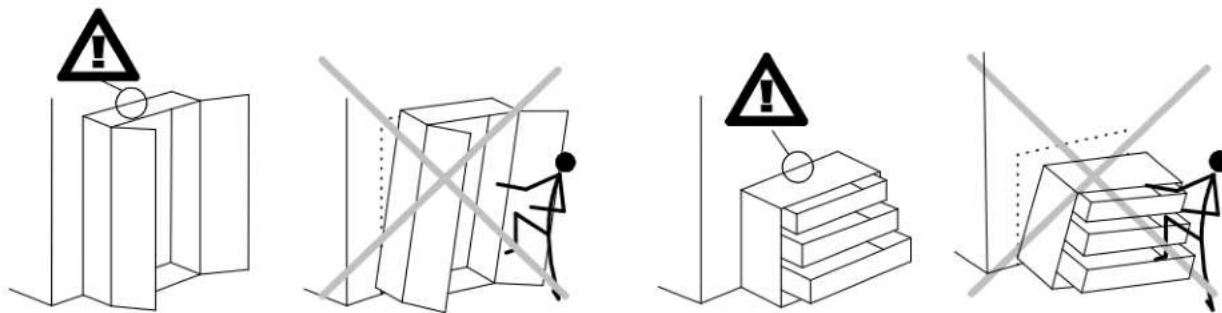

SK:

VÝSTRAHA PRED PREVRÁTENÍM!

Tento produkt musí byť natrvalo pripevnený k stene pomocou dodanej(-ých) konzoly (konzol), aby sa predišlo smrteľnému úrazu v prípade, že sa prevráti.

Balenie obsahuje iba skrutky, ktorými sa pripevňujú k produktu samotné konzoly chrániace pred prevrátením. Kontaktujte miestnu predajňu pre domácich majstrov alebo železiarstvo, kde vám poradia ohľadom správneho typu skrutiek/príchytiiek pre váš typ steny.

CZ:

VAROVÁNÍ TÝKAJÍCÍ SE SKLOPENÍ!

Tento výrobek musí být trvale připevněn na stěnu pomocí přiložených držáků, aby nedošlo ke smrteľnému zranění, kdyby se sklopil. Sada obsahuje pouze šroubky pro upevnění držáků zabraňujících sklopení k výrobku. Ohledně správného typu vrutů/hmoždinek pro daný typ stěny se obraťte na vhodný obchod nebo železářství.

HR:

UPOZORENJE O OPASNOSTI OD PADA!

Ovaj proizvod mora stalno da bude pričvršćen za zid držačem (držačima) iz pakovanja, da bi se izbegla smrtonosna povreda u slučaju da proizvod padne.

Pakovanje sadrži samo šrafove za pričvršćavanje na proizvod držača protiv padanja. Kontaktirajte prodavnicu "Uradi sam" ili gvoždarsku radnju za savet o ispravnoj vrsti šrafova/tiplova za tip zida koji imate.

RO:

ATENȚIONATE RISC RĂSTURNARE!

Acest produs trebuie să fie atașat permanent de perete folosind suportului(rilor) furnizat(e) pentru a preveni rănirea mortală în cazul în care se răstoarnă.

Pachetul conține doar șuruburi, care sunt folosite pentru a atașa suporturile anti-răsturnare de produs. Contactați magazinul local de bricolaj sau magazinul de fierărie pentru sfaturi despre tipul corect de șuruburi/dibluri pentru tipul dumneavoastră de perete.

SI:

OPOZORILO PRED PREVRNITVIJO!

Ta izdelek mora biti trajno pritrjen na steno s pomočjo priloženih nosilcev, da se preprečijo smrtne poškodbe v primeru prevrnitve.

Paket vsebuje samo vijake, s katerimi se na izdelek pritrdijo sami nosilci za zaščito pred prevrnitvijo. Za nasvet o pravilni vrsti vijakov/vijakov za vaš tip stene se obrnite na lokalno trgovino z gradbenimi pripomočki.

HU:









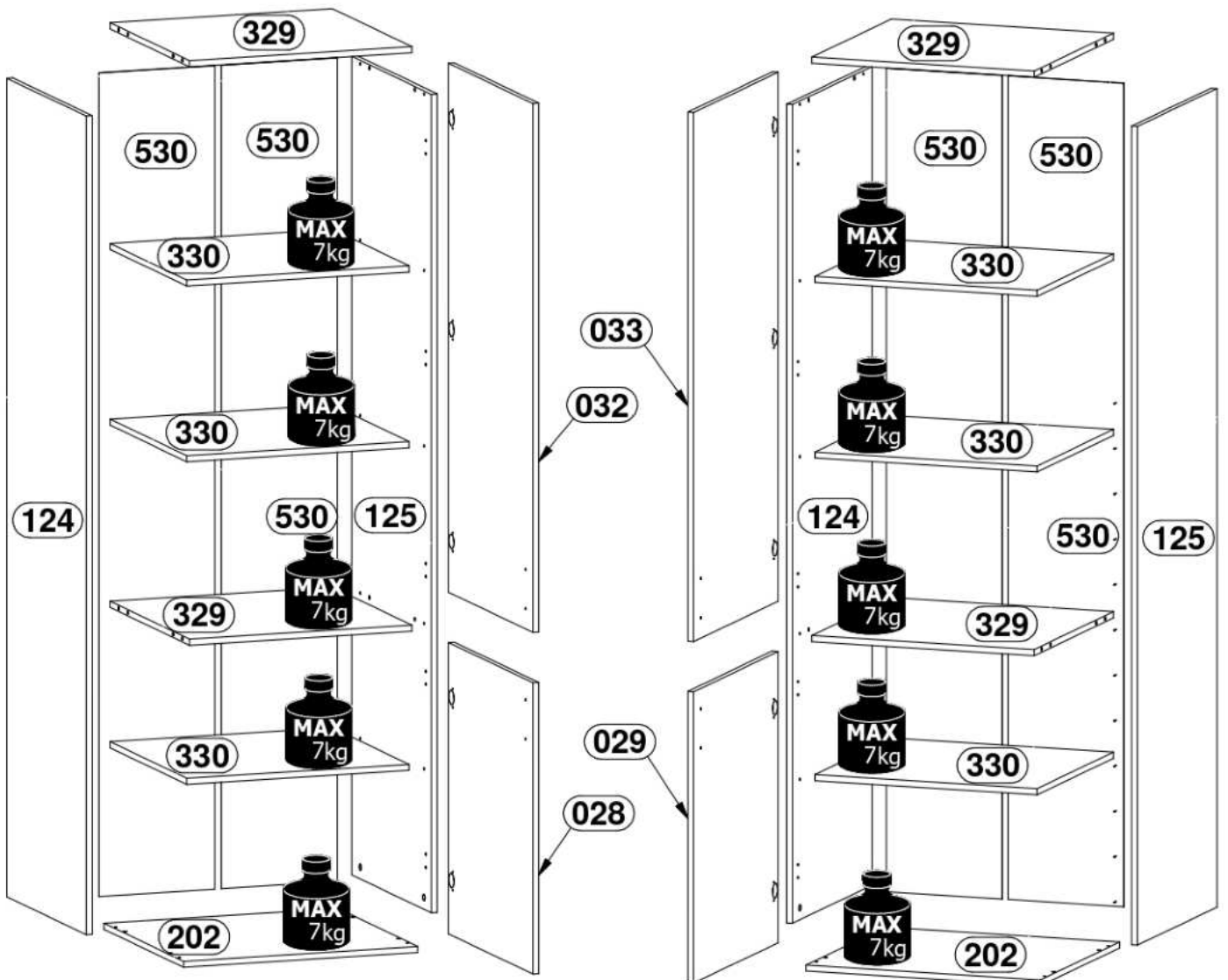
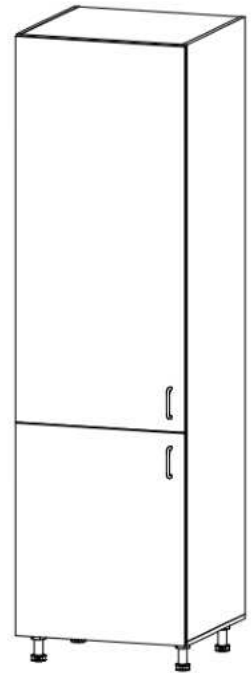
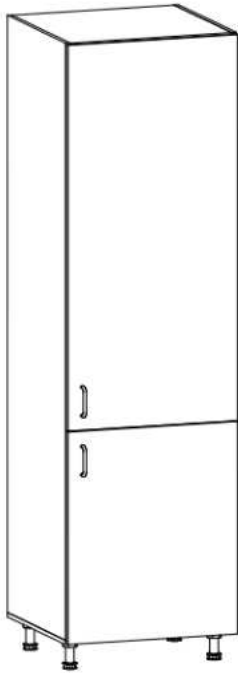

FELBORULÁSRA VONATKOZÓ FIGYELMEZTETÉS!

Ezt a terméket tartósan a falhoz kell rögzíteni a mellékelt konzol(ok) segítségével, hogy elkerülje a halálos sérülést felborulás esetén.

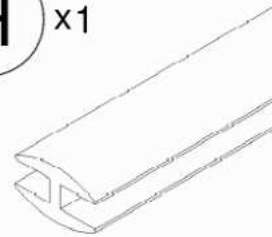
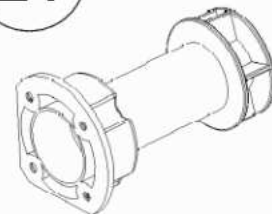
A csomag csak csavarokat tartalmaz, amelyekkel a borulásgátló konzolokat rögzítik a termékhez. Forduljon a helyi lakberendezési bolthoz vagy hardverbolthoz, hogy tanácsot kapjon az Ön faltípusának megfelelő csavarok/kapcsok típusával kapcsolatban.

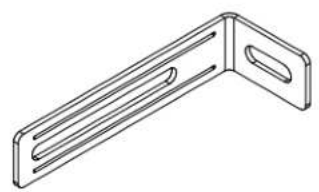
D60R

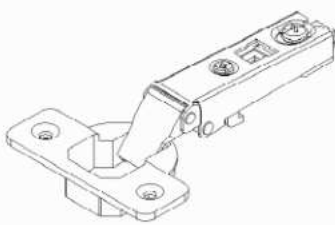

<p>A x12</p>  <p>Ø8x35mm</p>	<p>B x12</p> 	<p>C x12</p>  <p>Ø15x12mm</p>	<p>E x12</p> 
<p>G x40</p> 	<p>H x1</p>  <p>2015 mm</p>	<p>L1 x4</p> 	<p>M x2</p> 
<p>T4 x1</p>  <p>75x28x16 mm</p>	<p>W2 x28</p>  <p>Ø3,5x16mm</p>	<p>Y x12</p>  <p>Ø18 mm</p>	
<p>Zc x5</p>  <p>Zc-1</p>  <p>Zc-2</p>			

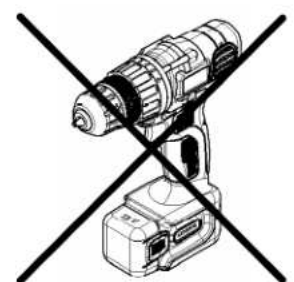

1

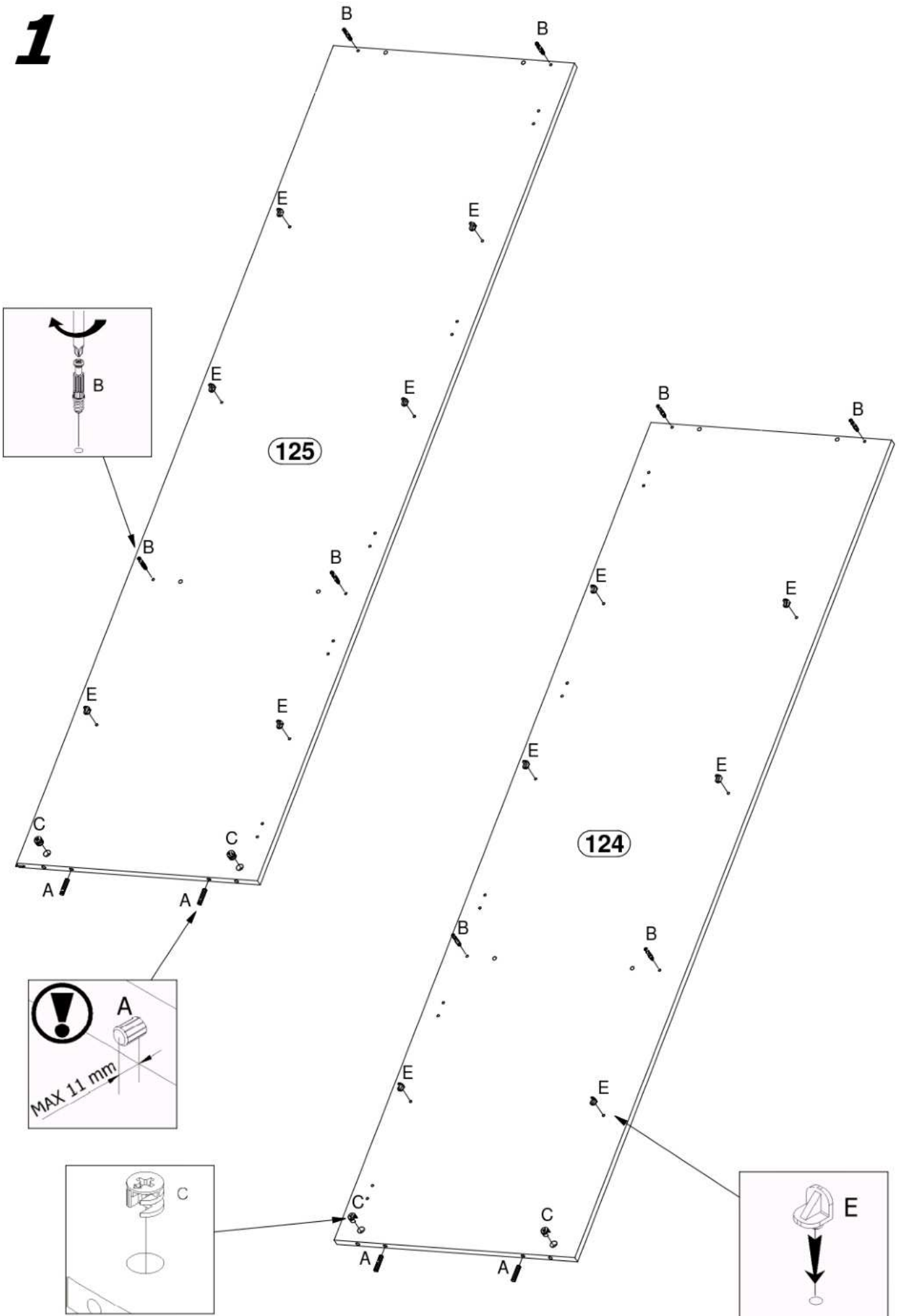

2

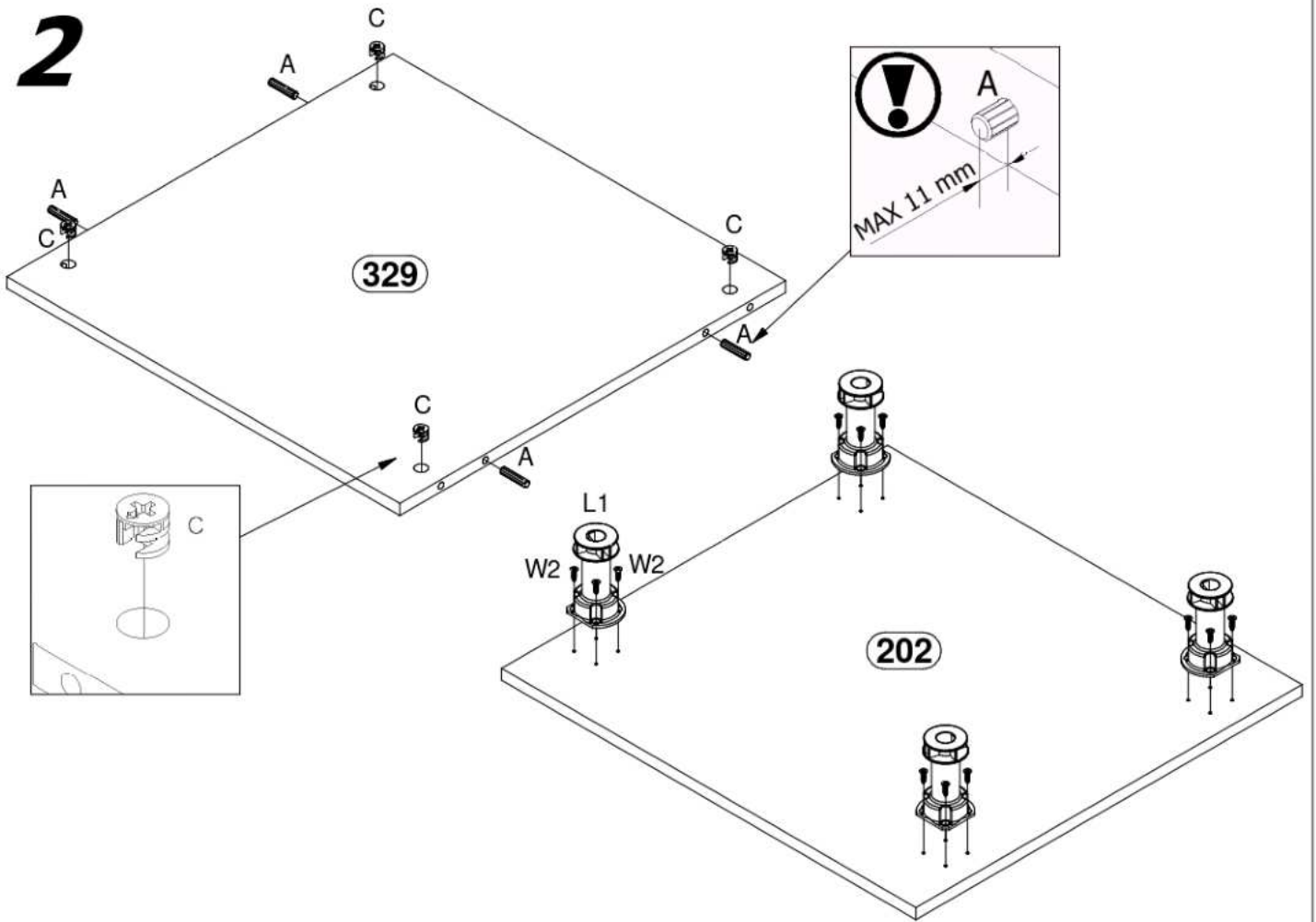

3

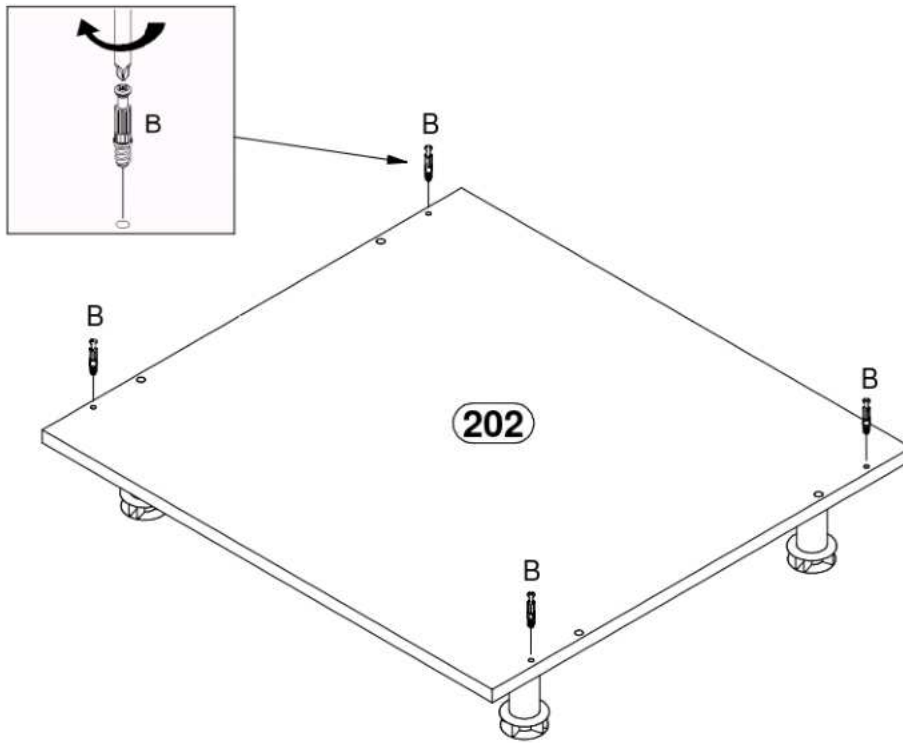

4

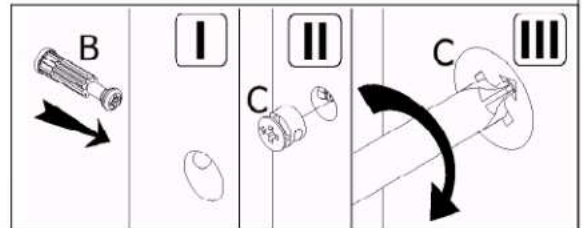
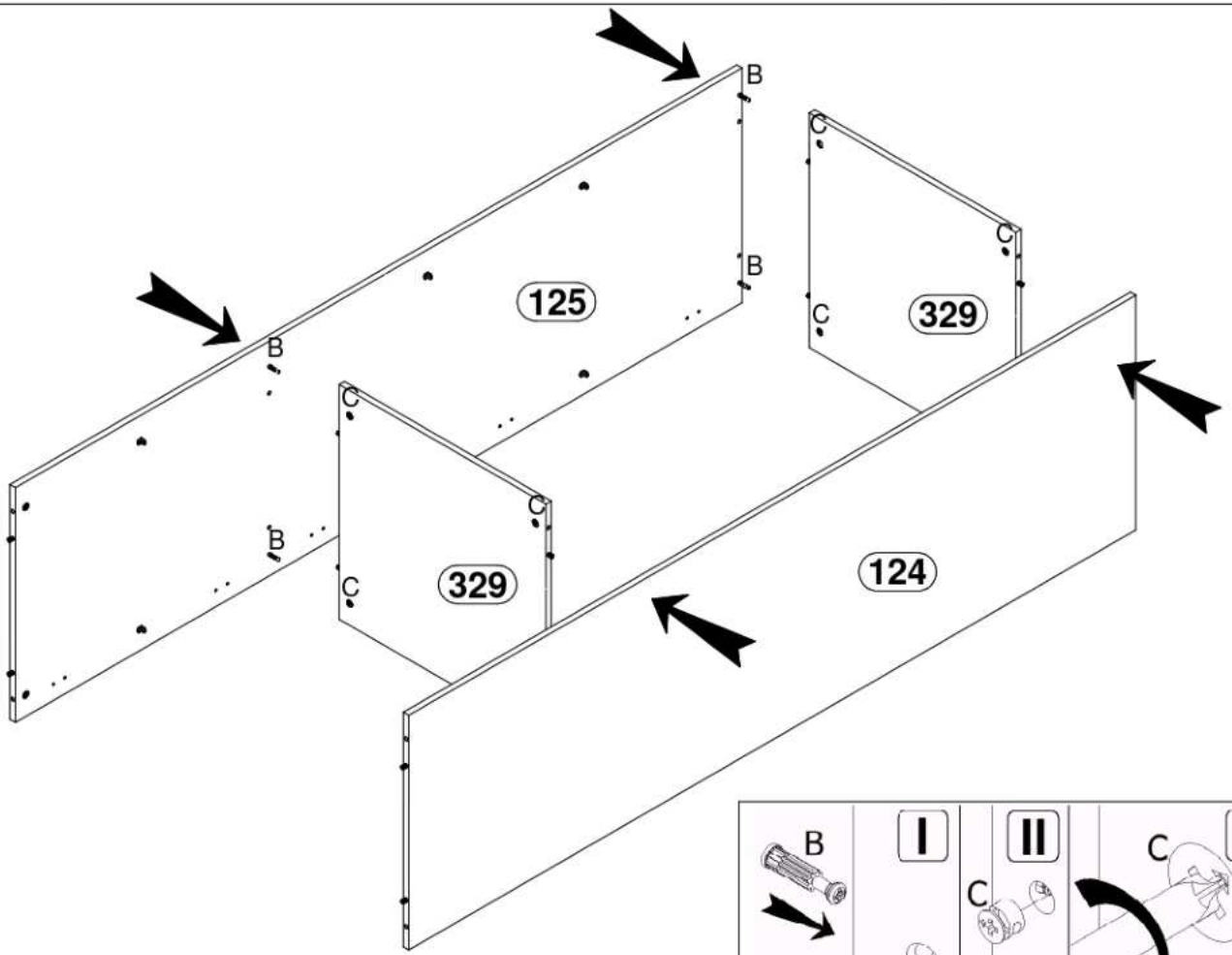

5

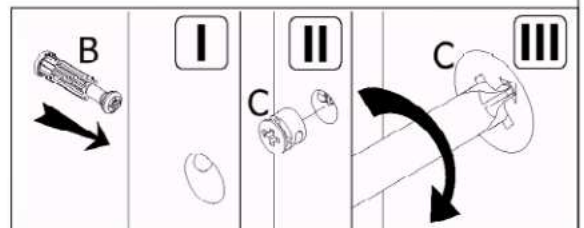
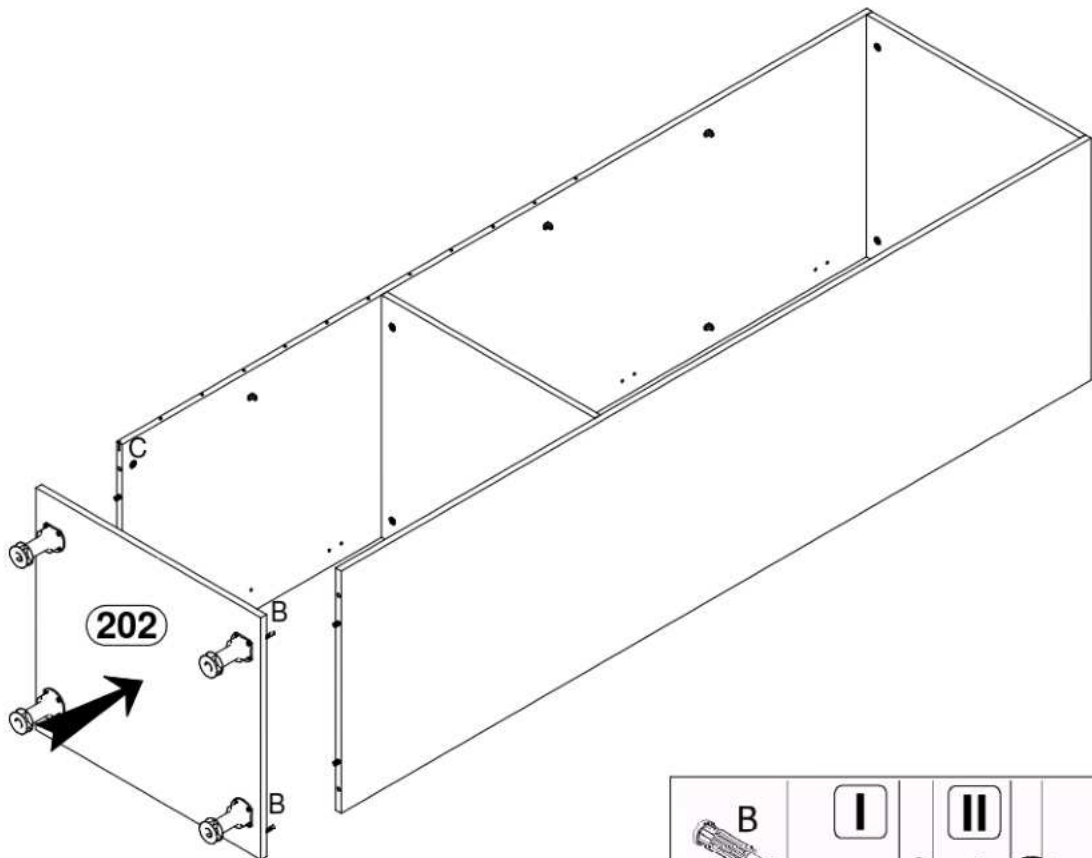

6

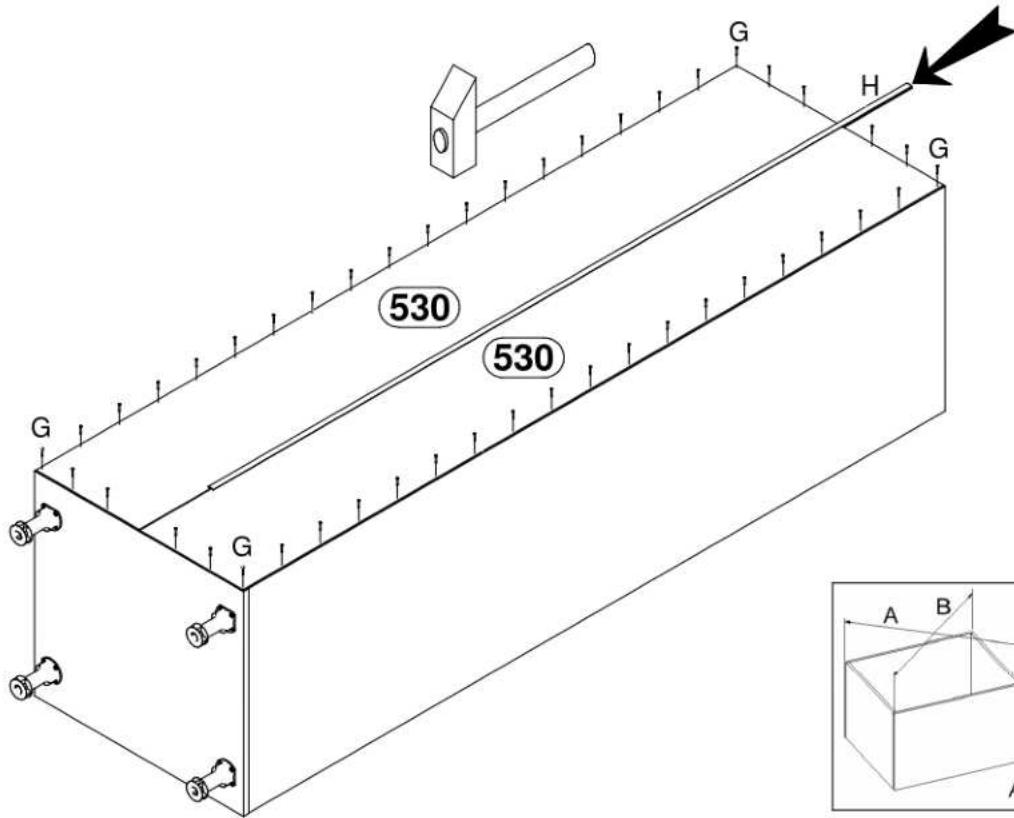

7

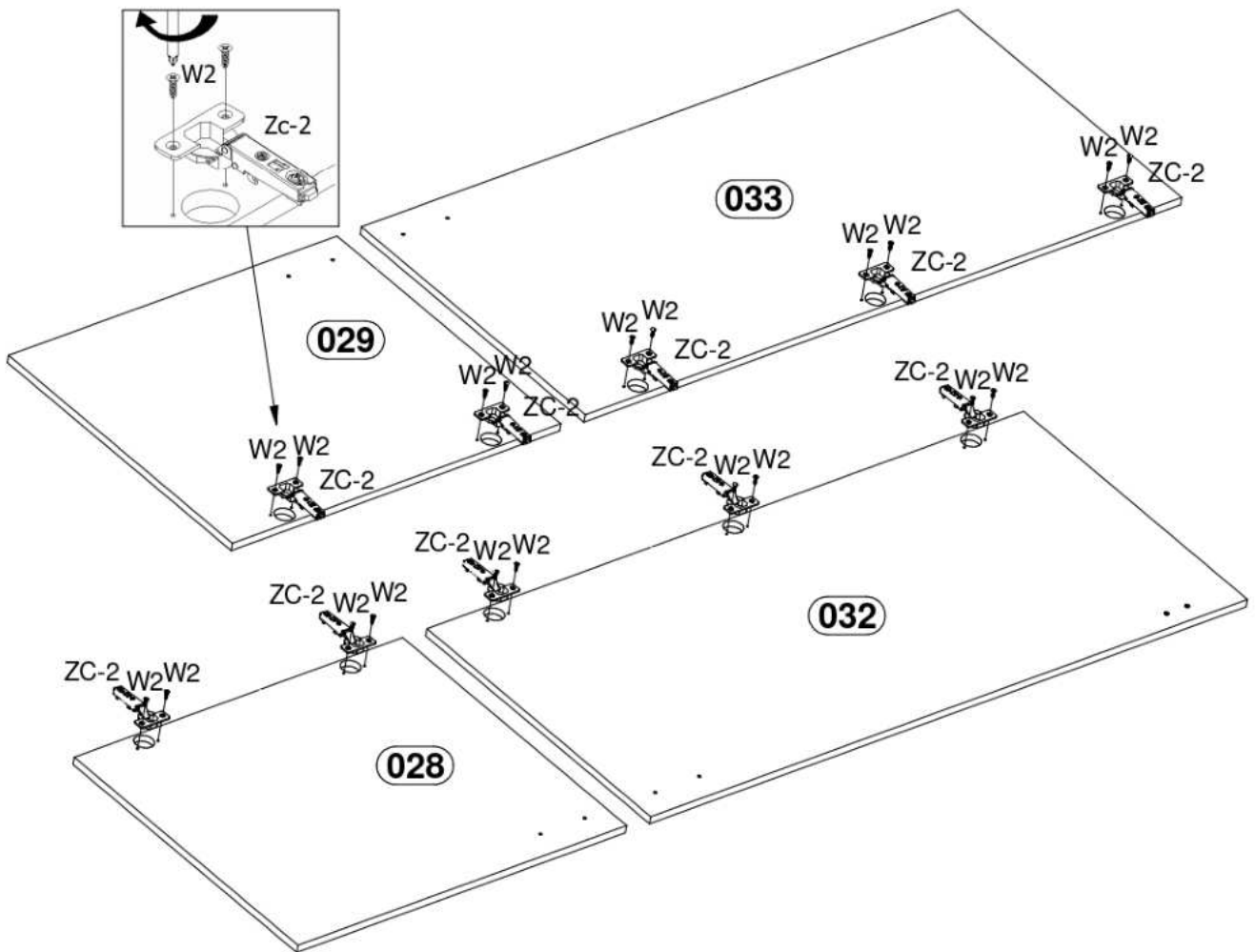

8

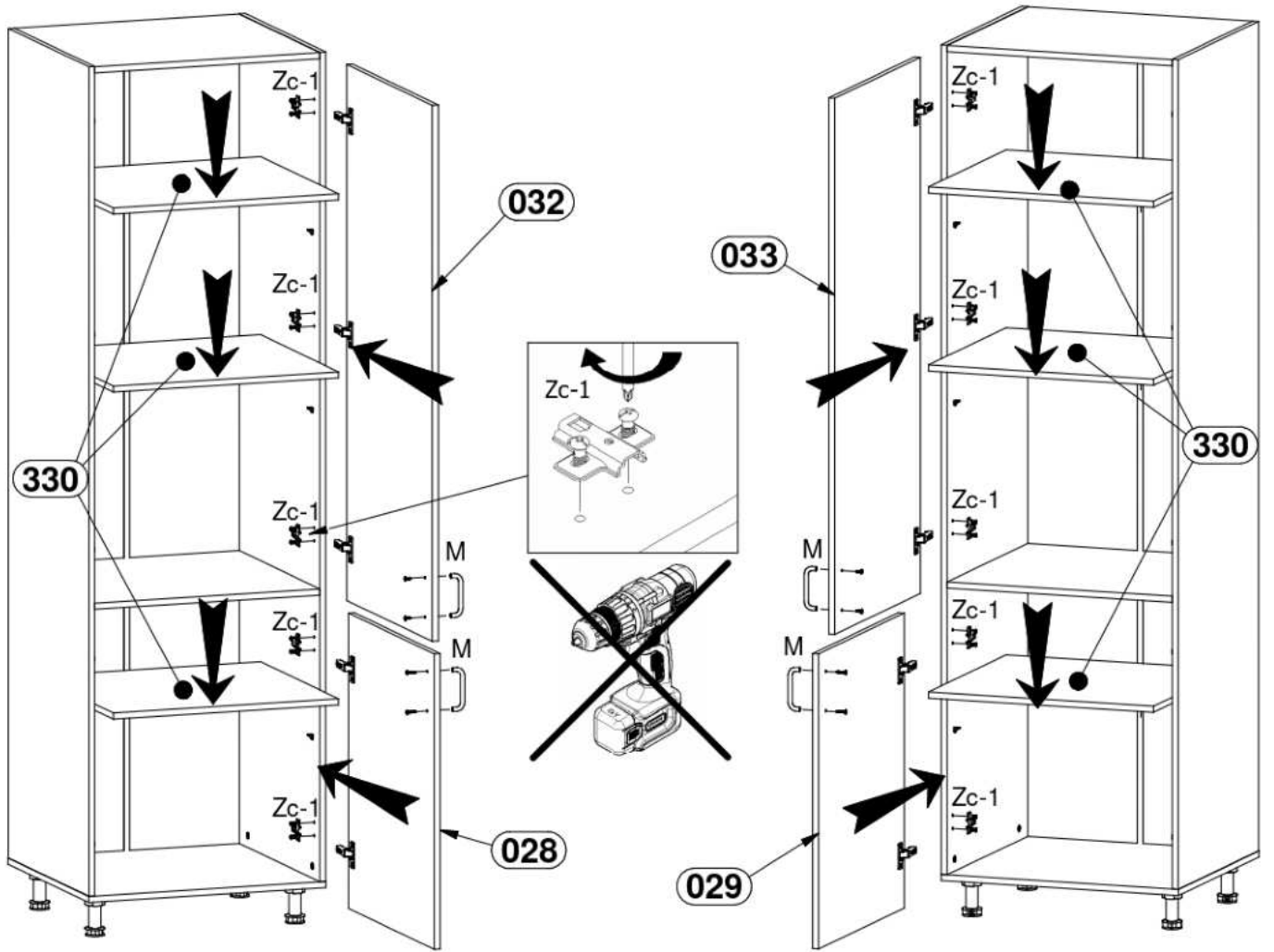

9

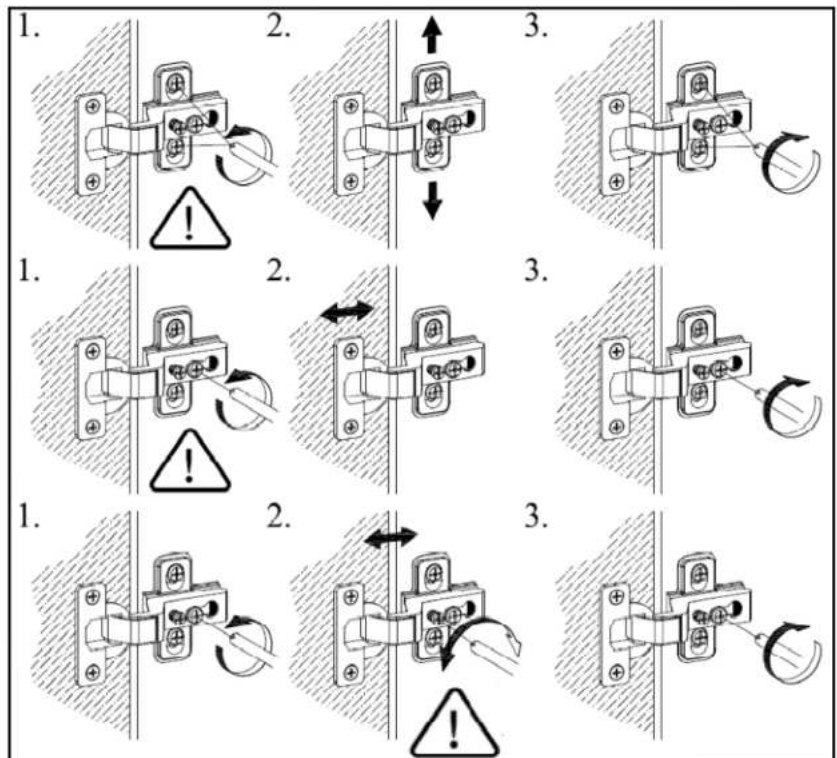
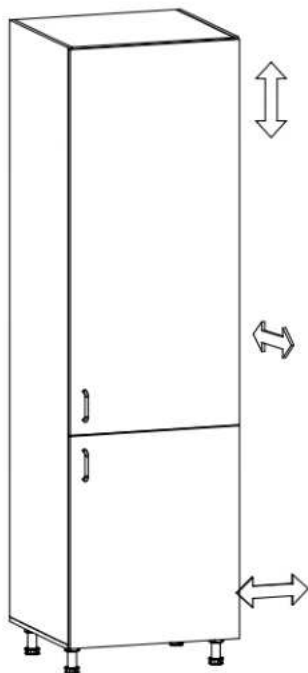

11

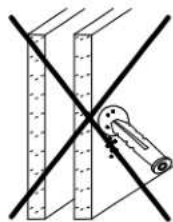
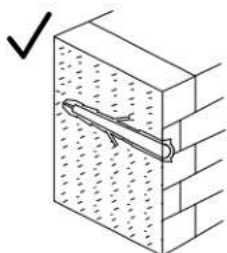
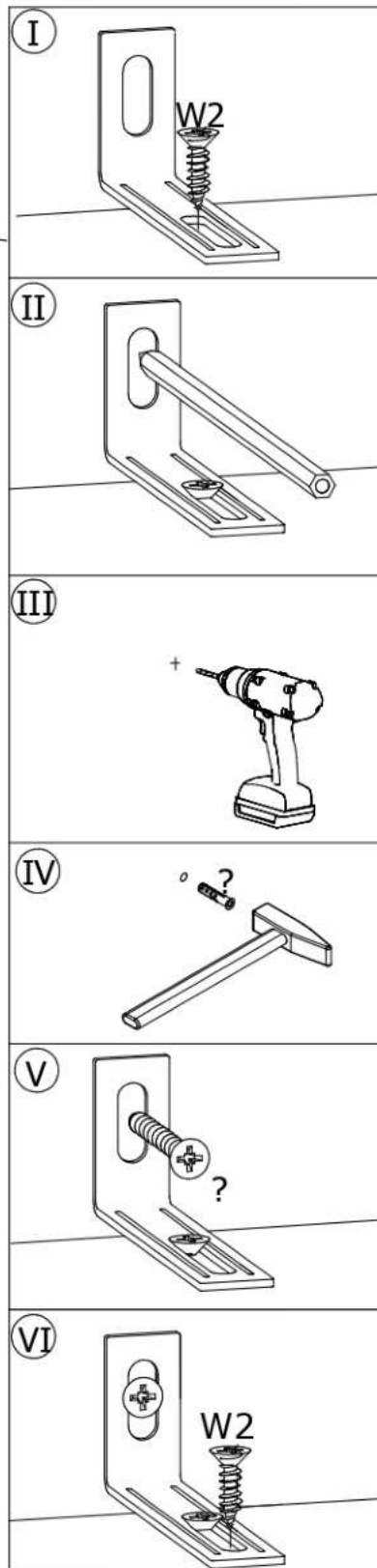
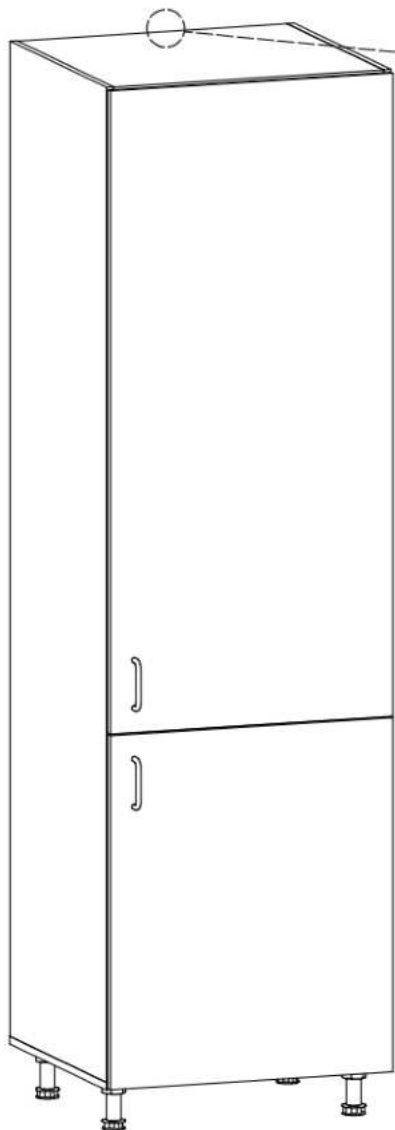
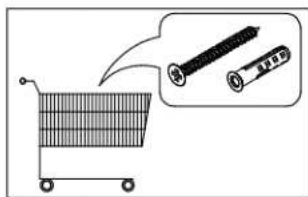
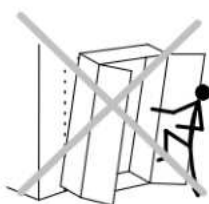

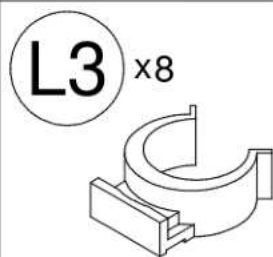
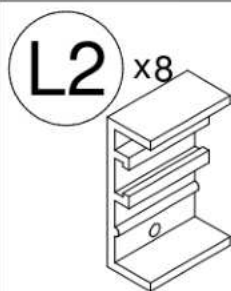
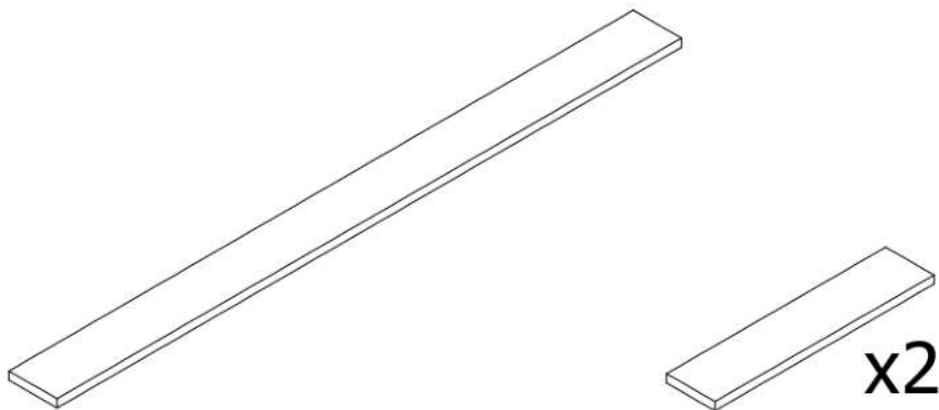
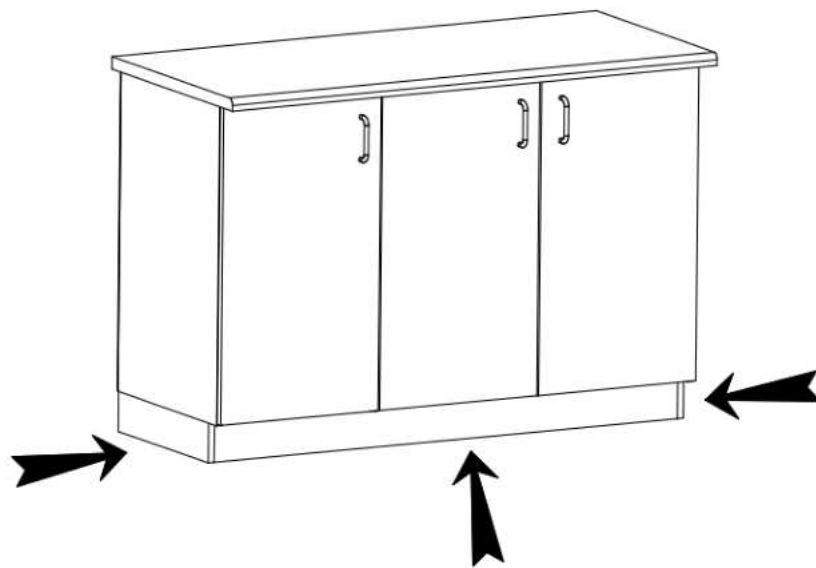

Ø3,5x16

10

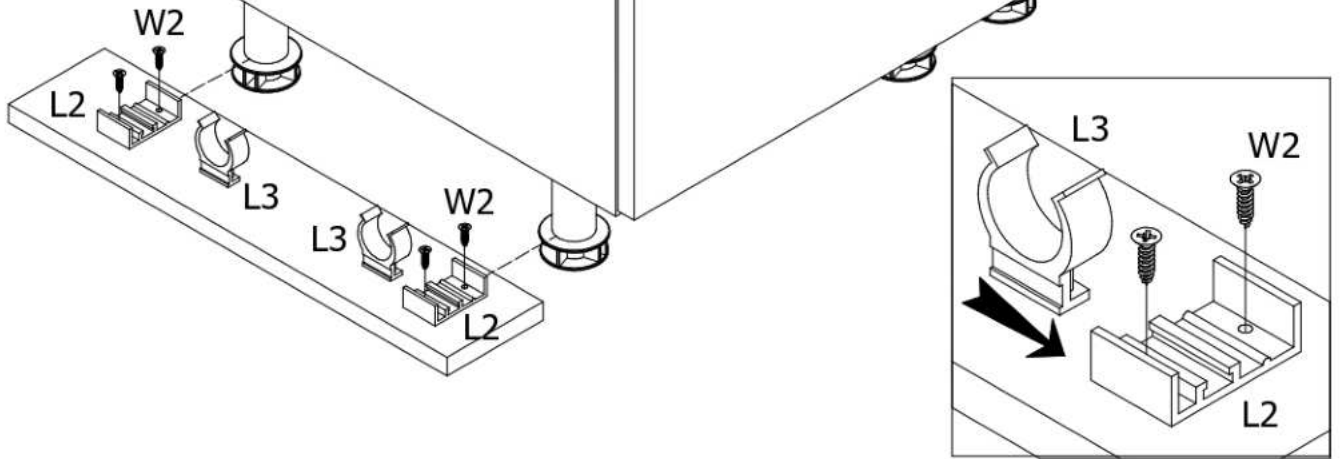

11

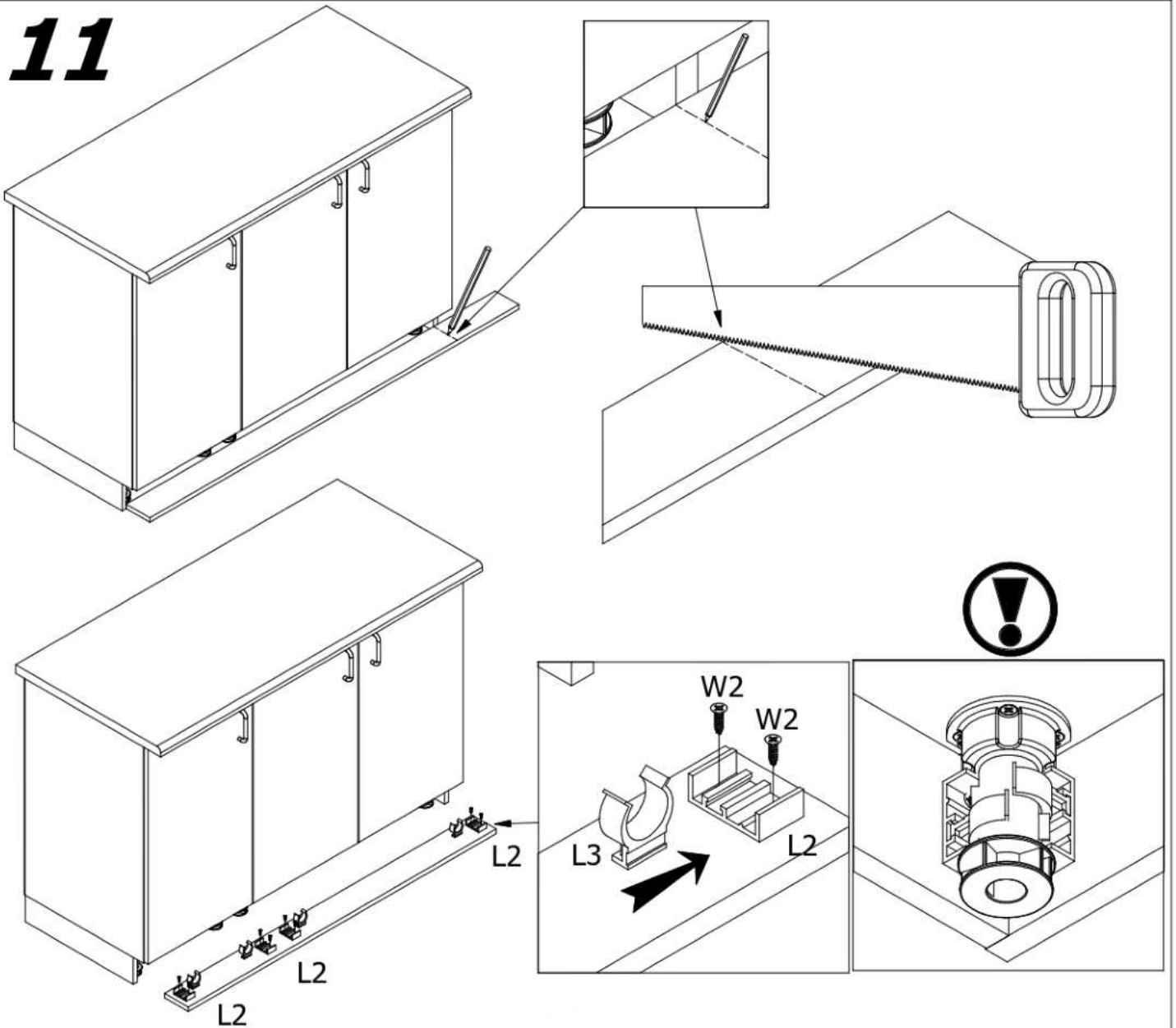

AURORA

D60S3

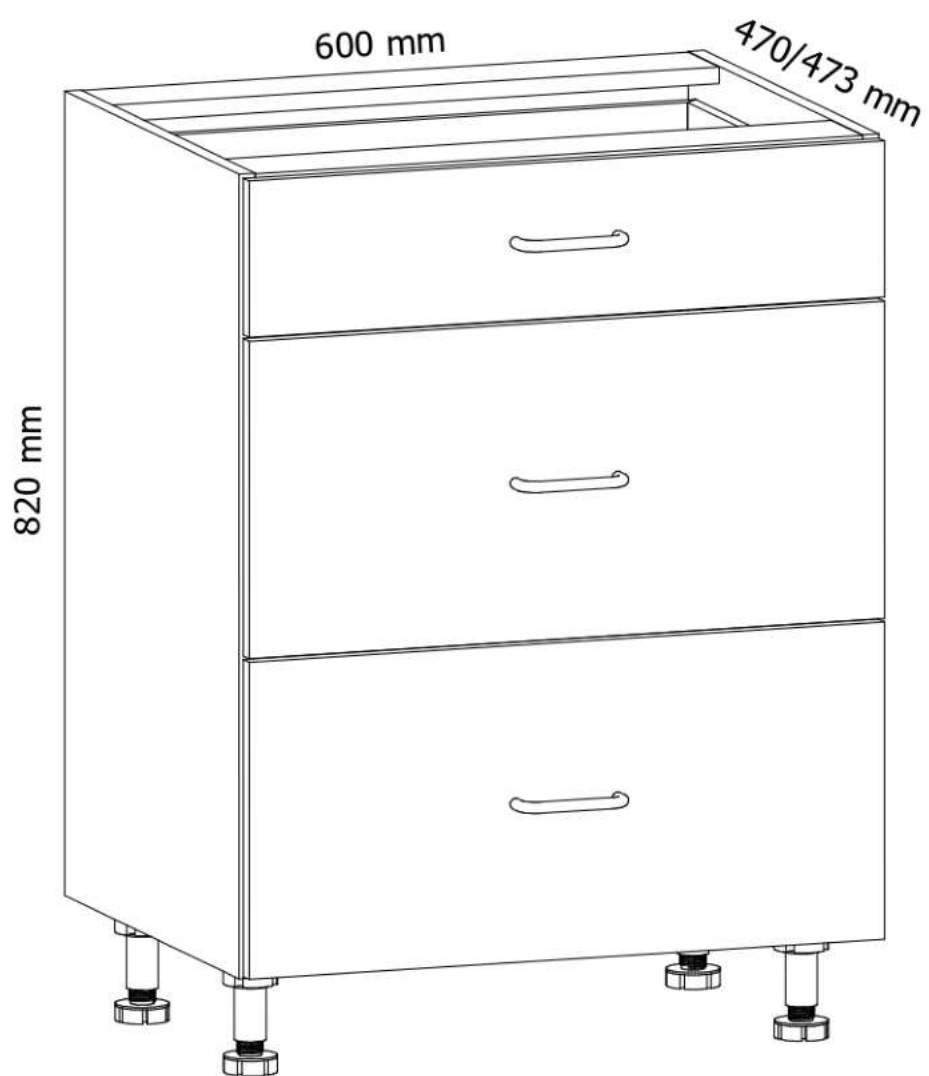

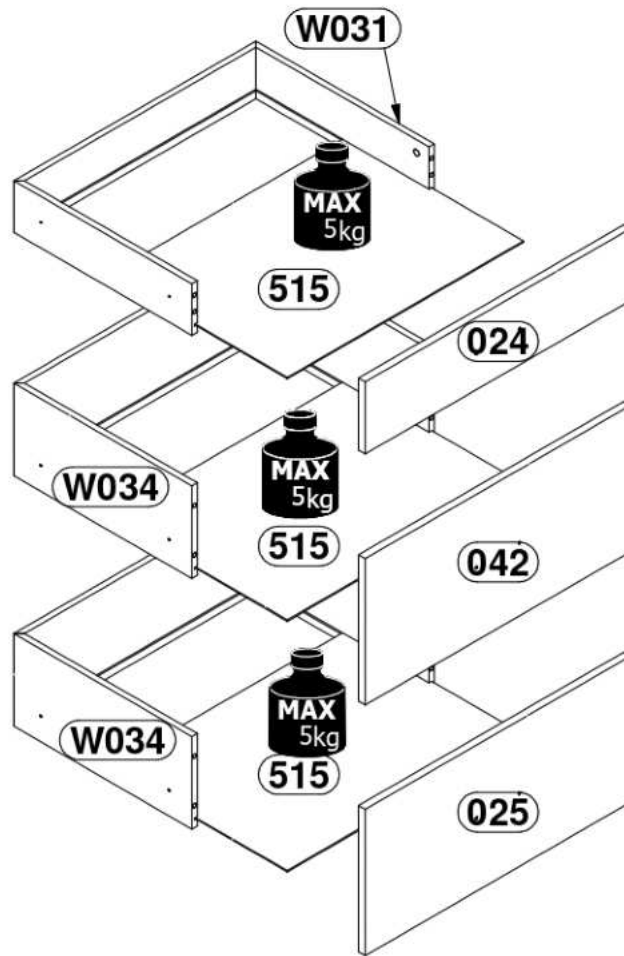
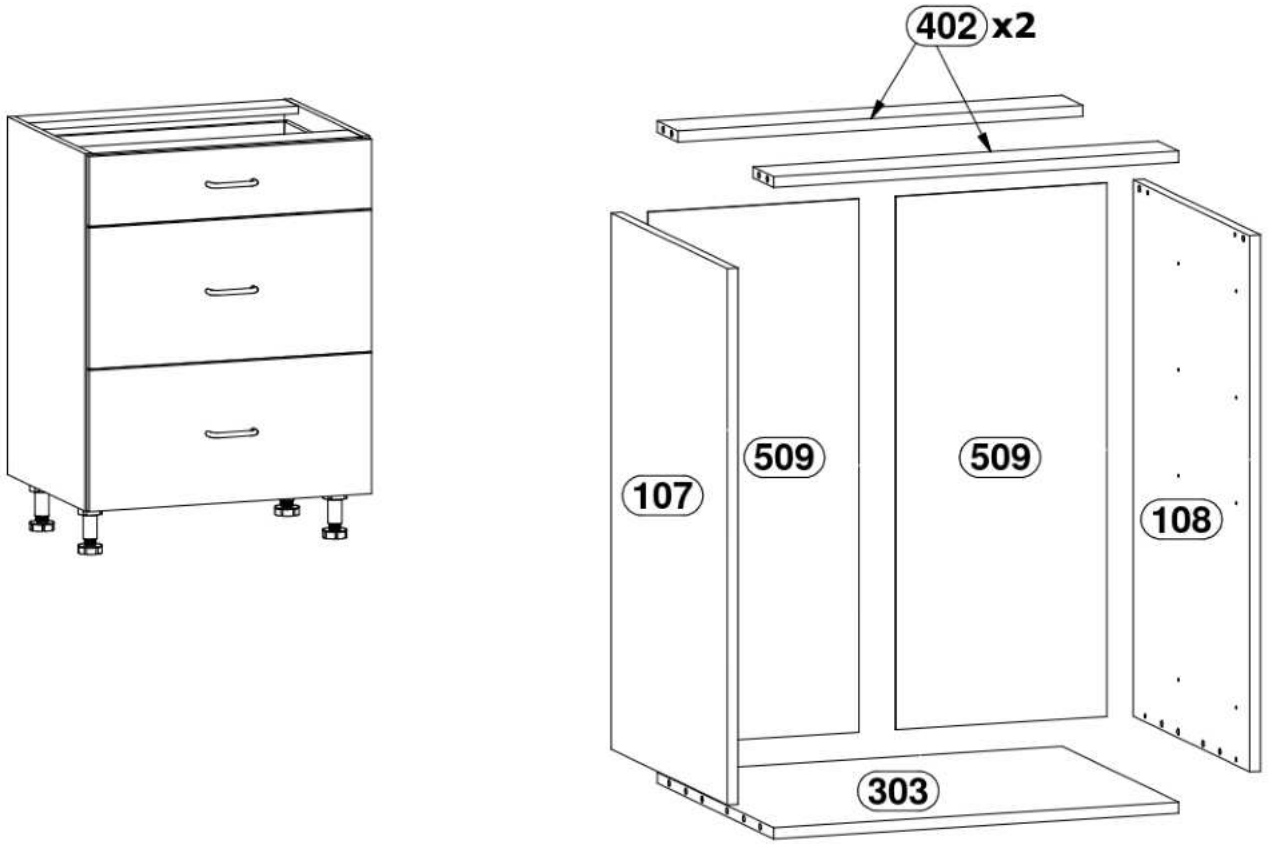

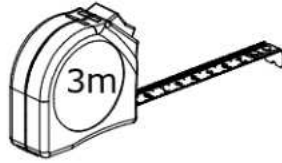
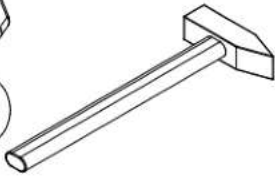
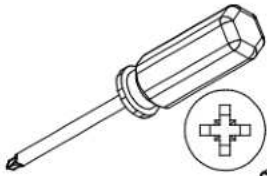

A1 x18

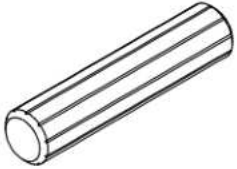

Ø8x35mm

B1 x14



Ø5x38mm

C1 x8

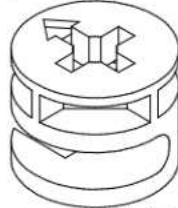

Ø15x12mm

C2 x6



Ø12x10mm

G1 x26



26mm

Hx1

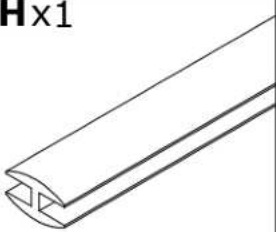

715mm

J x 6

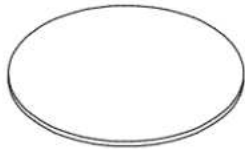

Ø21mm

L1 x 4



Ø50x95mm

Pc x6

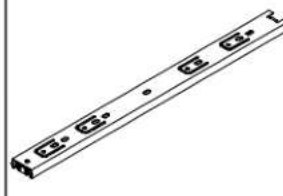

400mm

S3 x 3



400mm

Ux 3

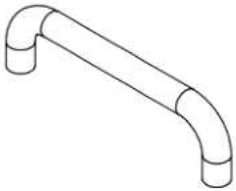

W1 x24



Ø3,5x13mm

W2x28

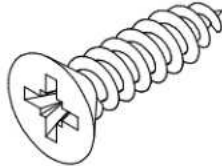

Ø3,5x16mm

X x6

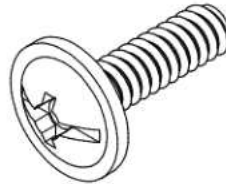

1

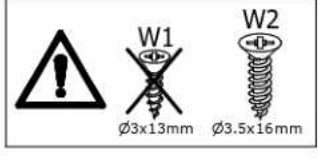
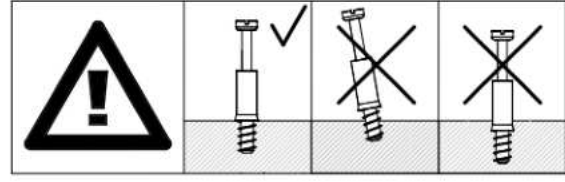
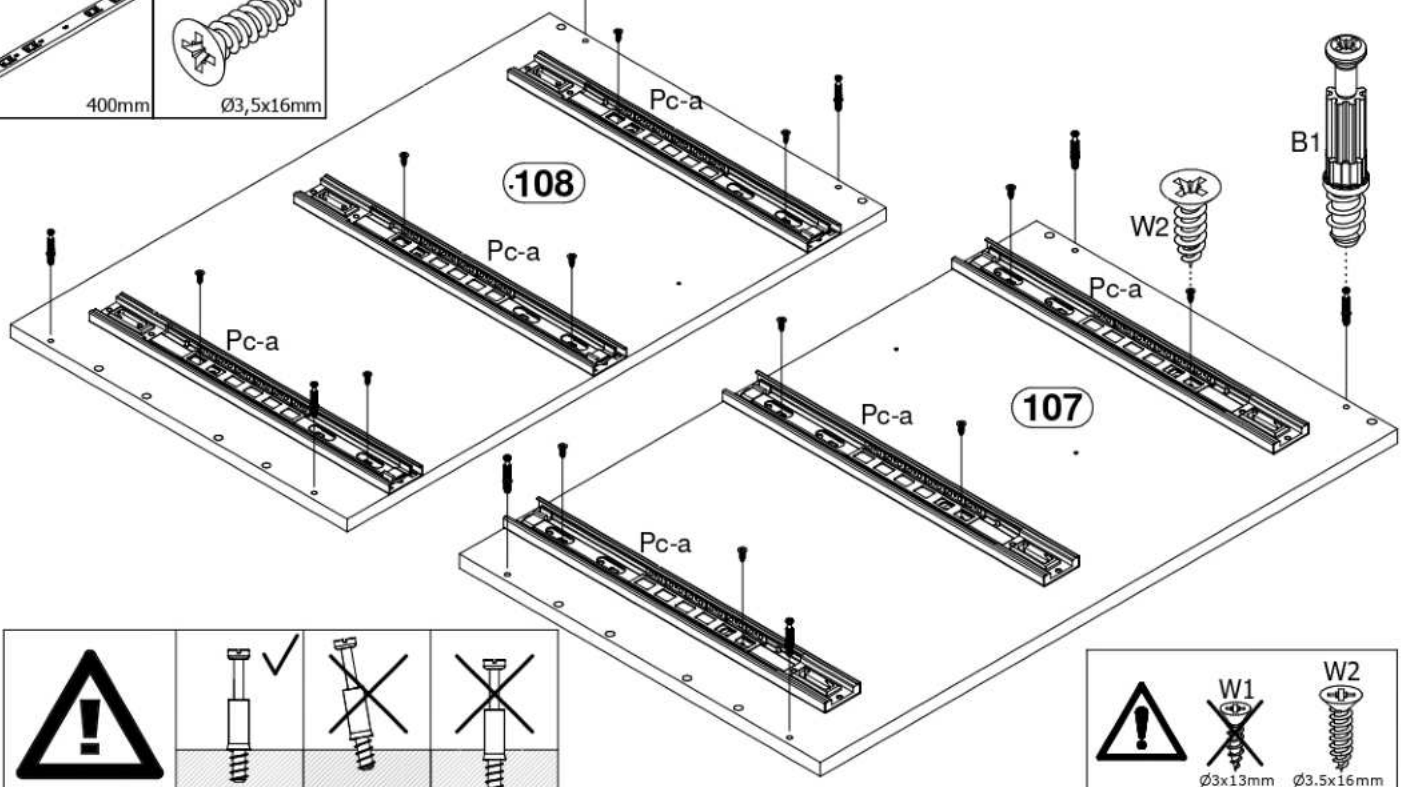
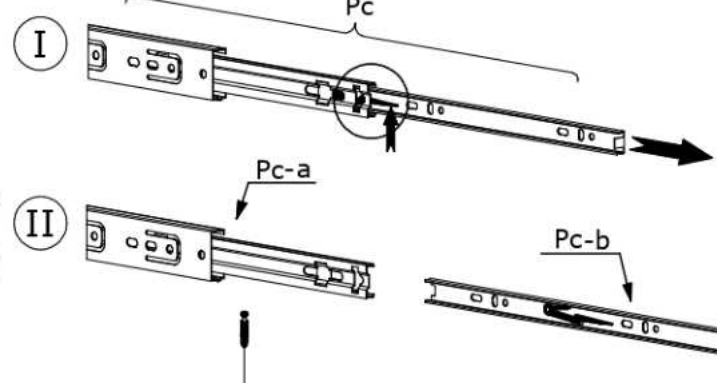
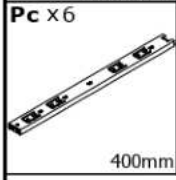
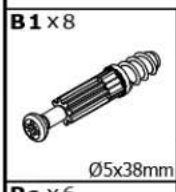

2

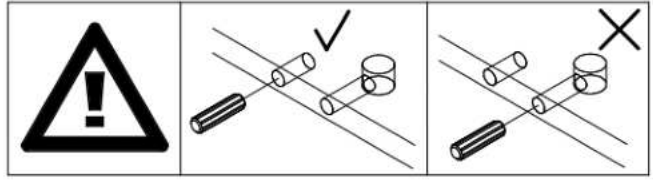
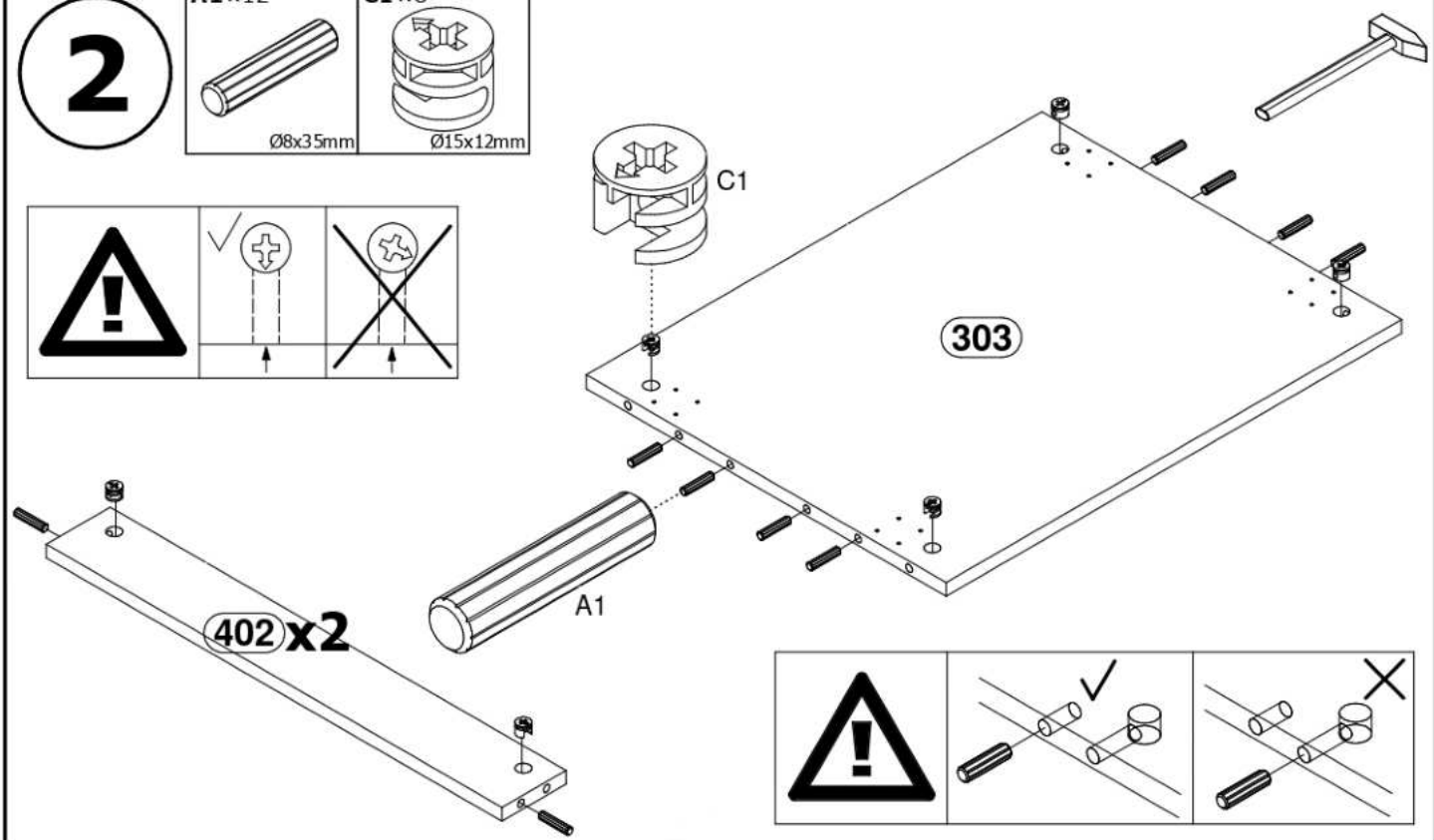
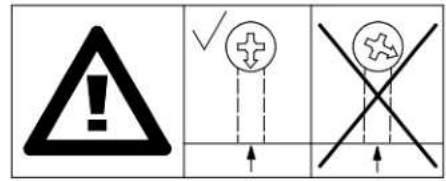
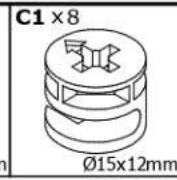
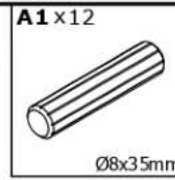

3

L1 x4



Ø50x95mm

W2 x16



Ø3,5x16mm

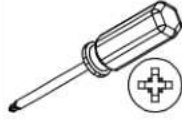

Ø3x13mm



Ø3,5x16mm

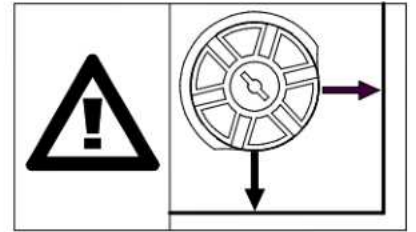
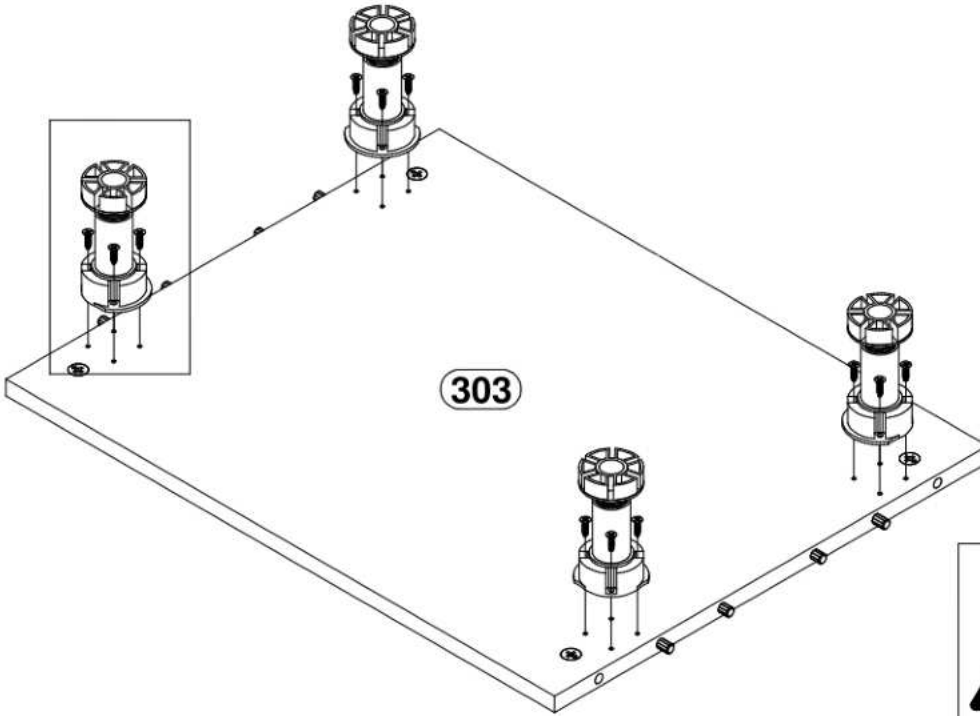
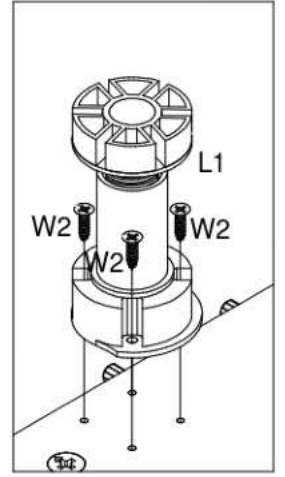

4

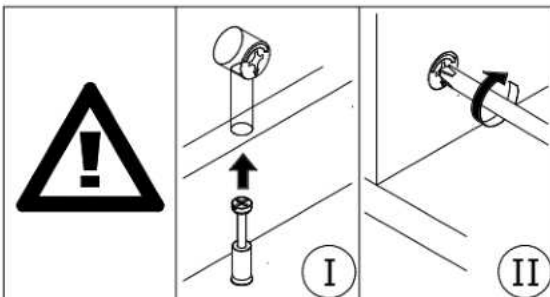
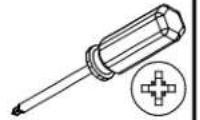
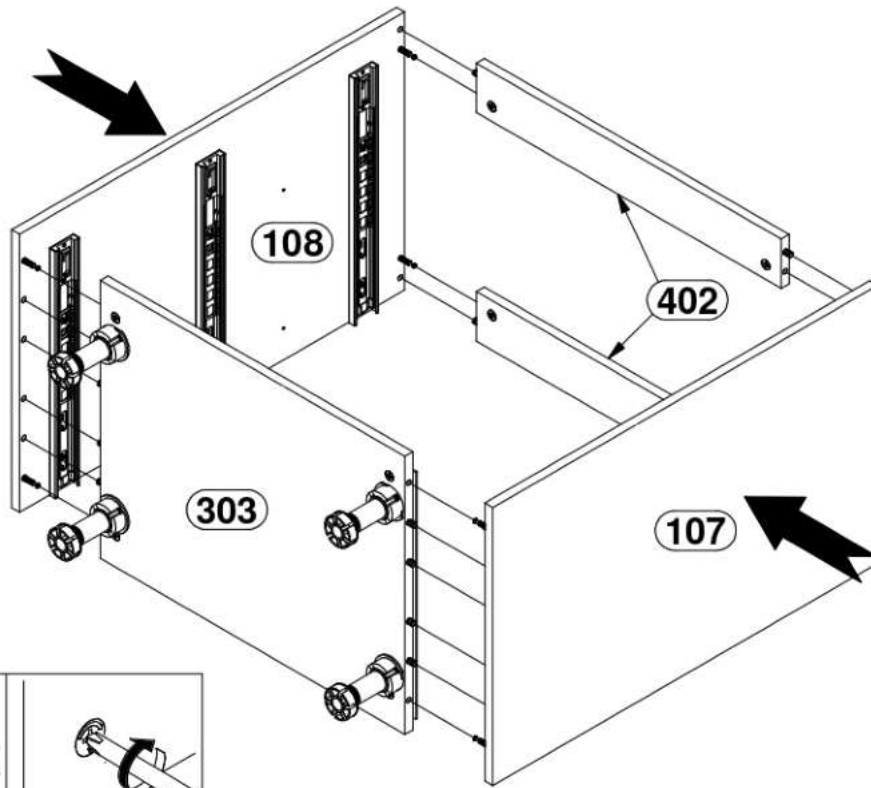

5

G1 x 26

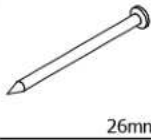

26mm

H x 1

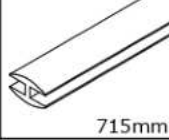

715mm

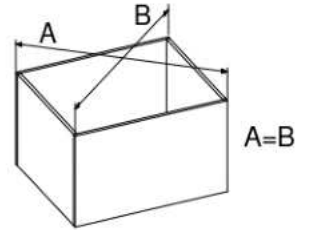
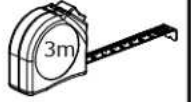
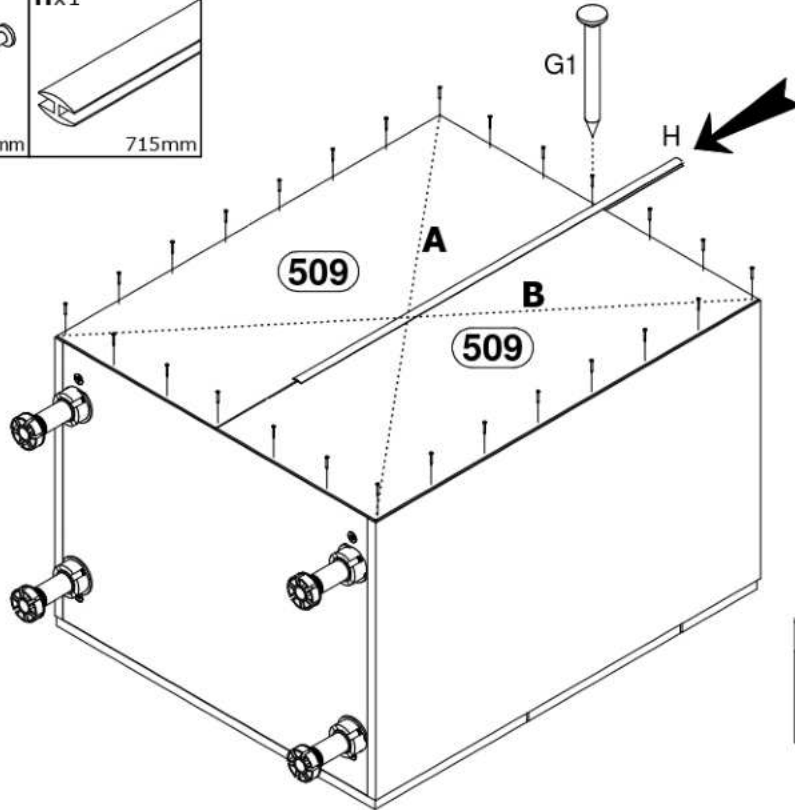

A=B ≡ 90°

6

A1 x 6



Ø8x35mm

B1 x 6



Ø5x38mm

Pc-b x 6

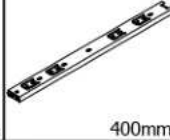

400mm

W1 x 12



Ø3,5x13mm

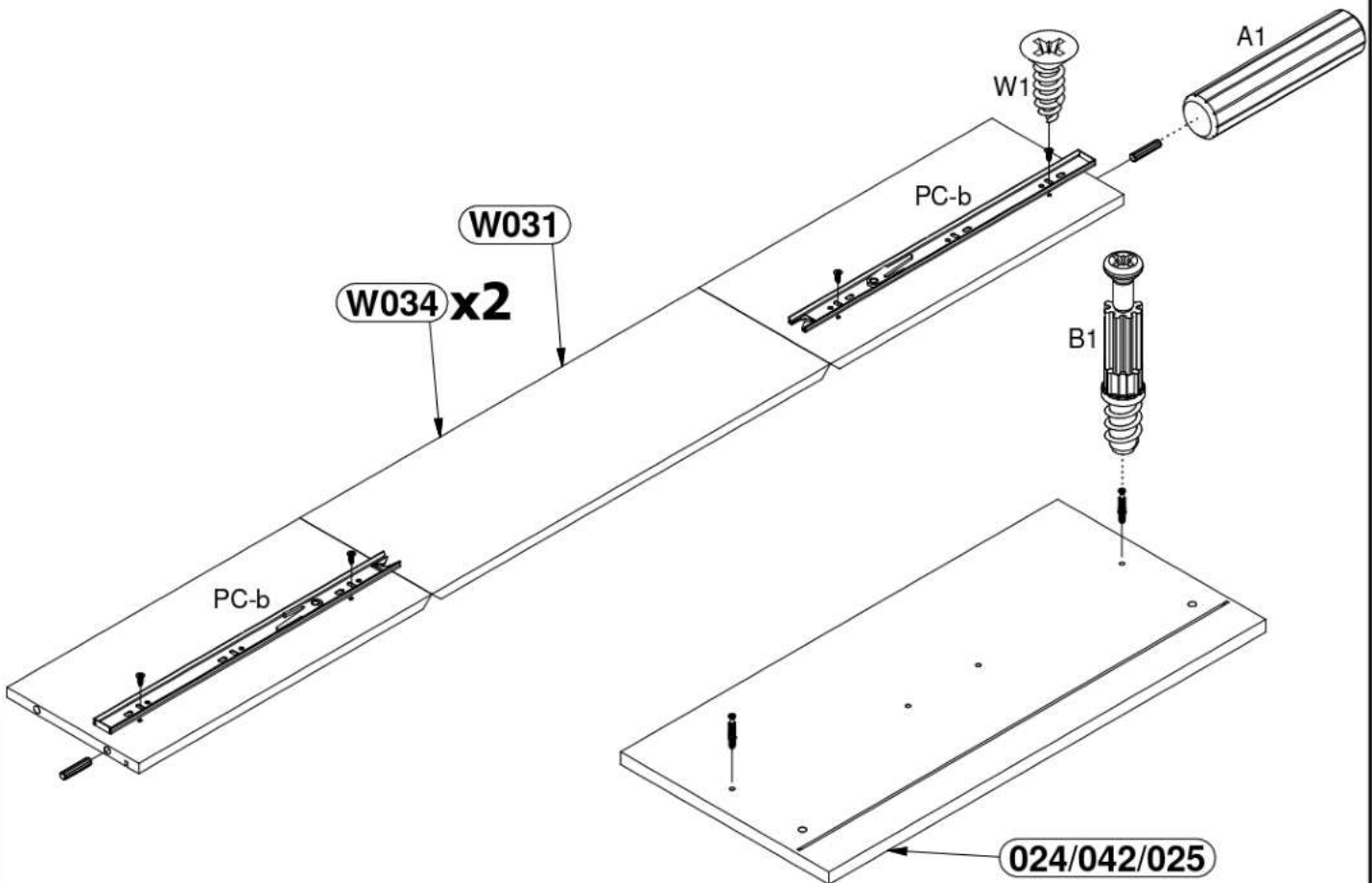
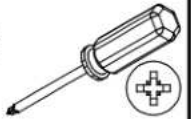

024/042/025

7

C2 x6

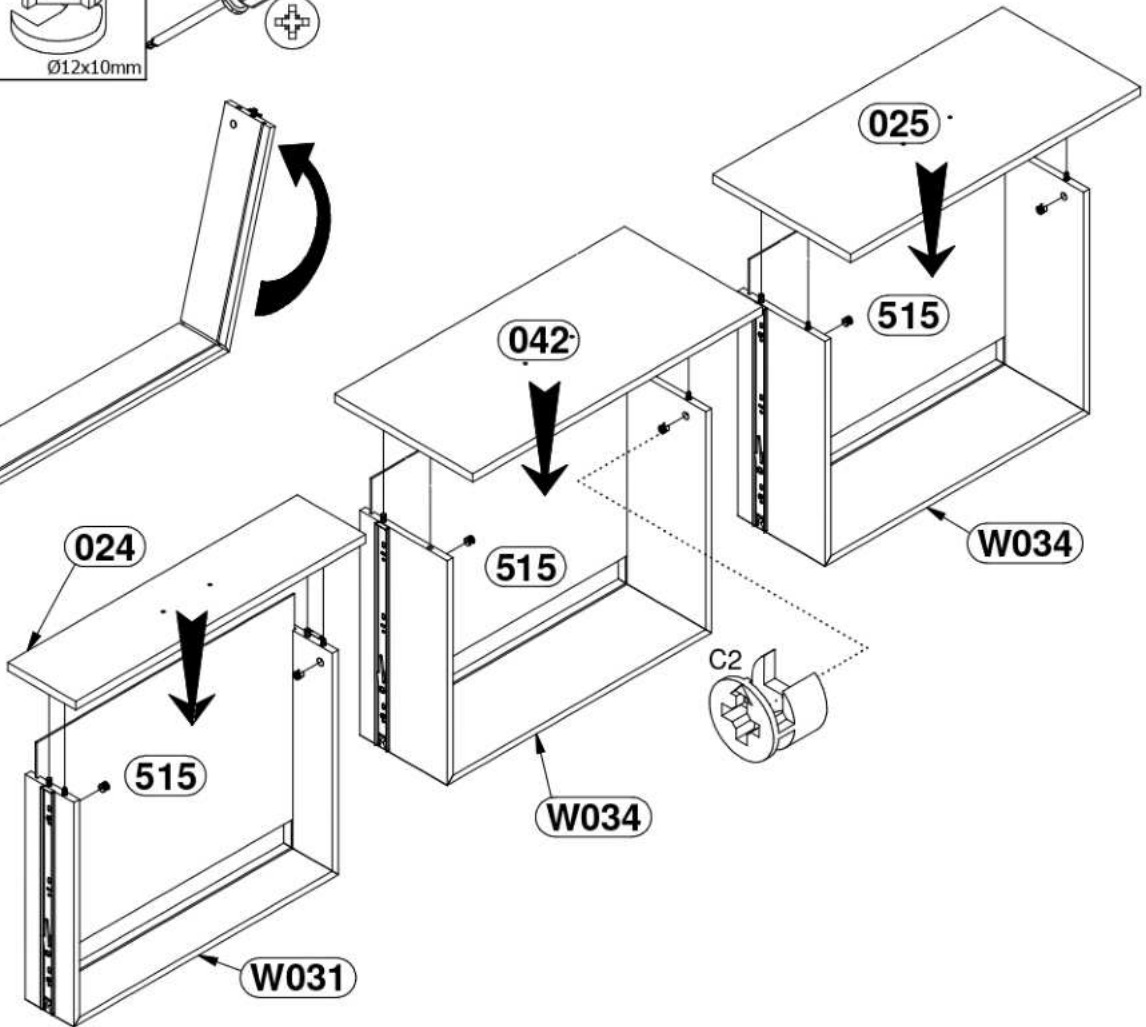
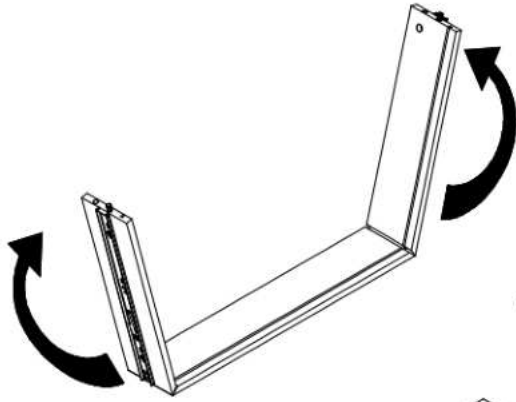
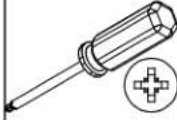

8

J x 6

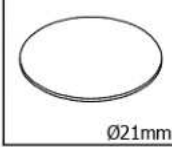

S3 x3



U x3



W1 x6



X x6

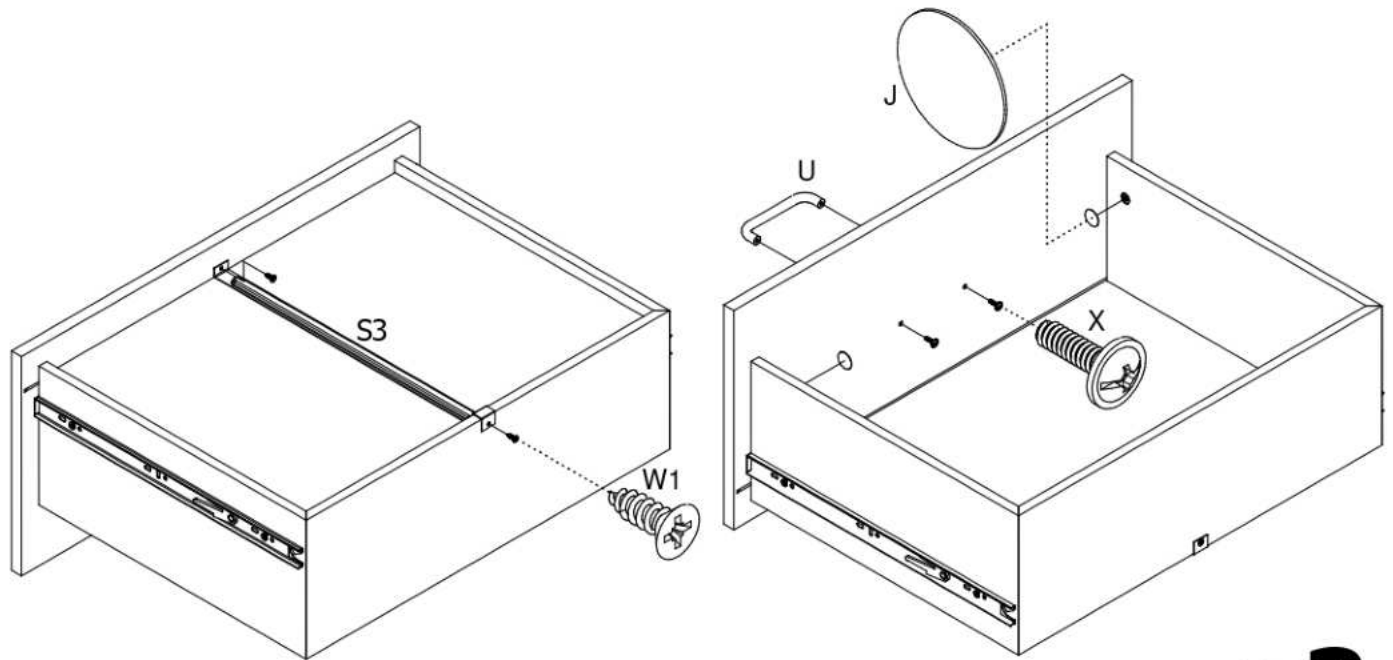
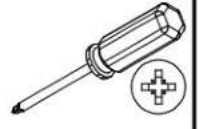

x3

9

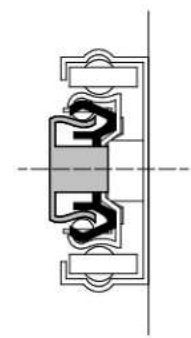
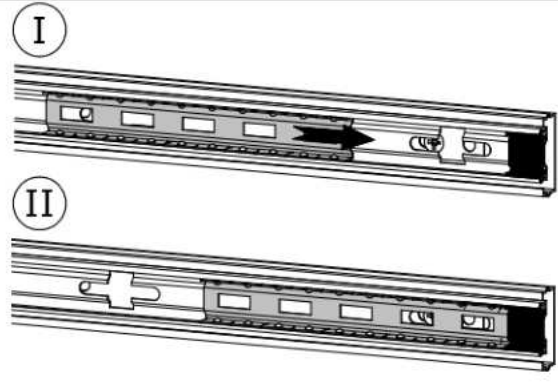
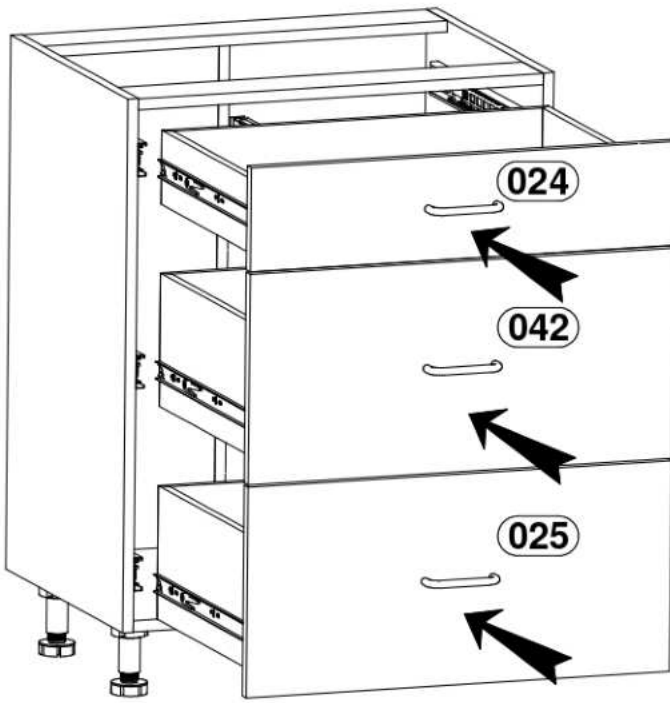

10

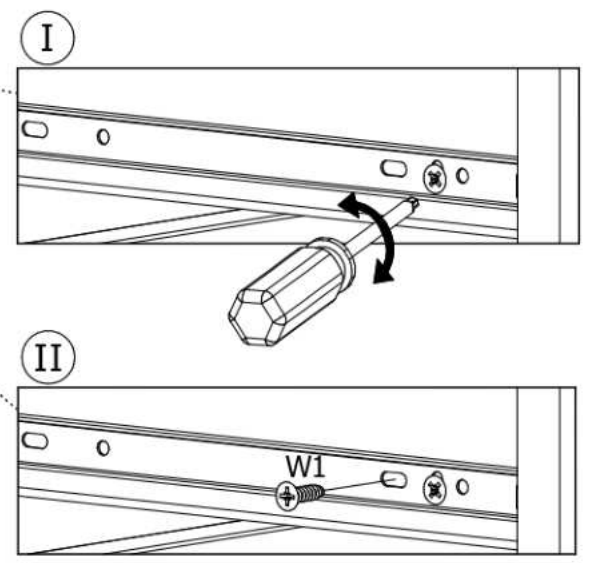
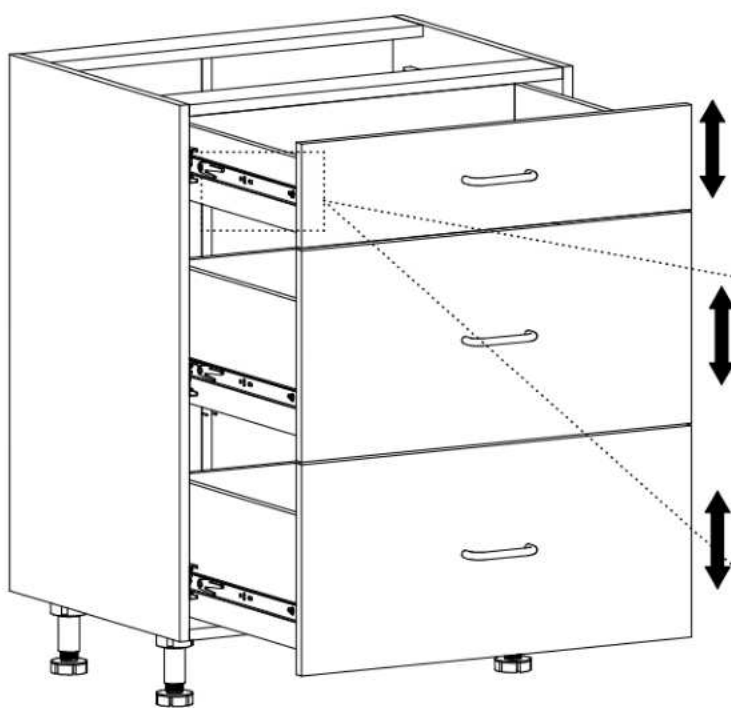
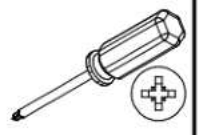

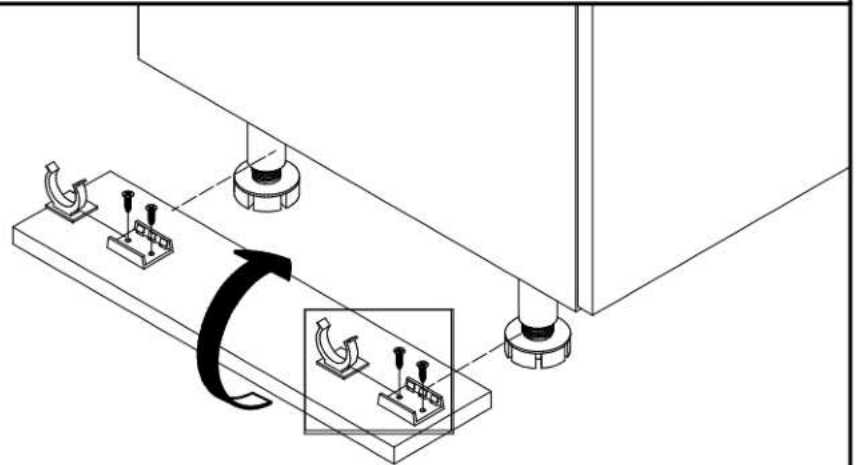
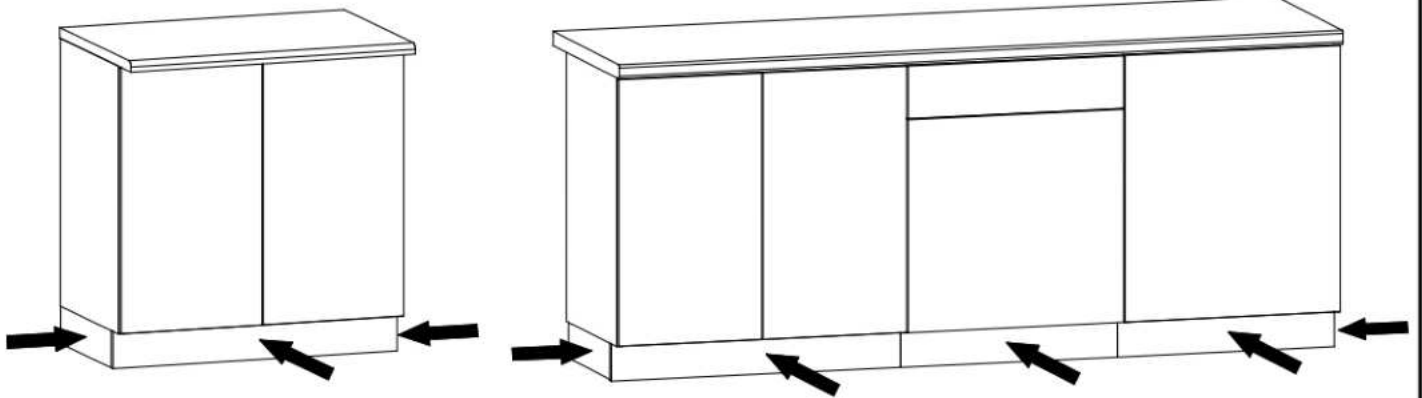
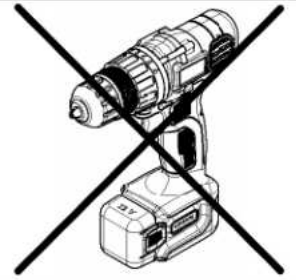
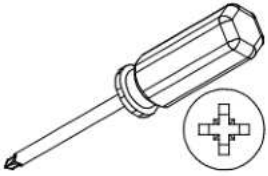

L6-a x4

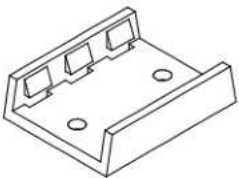

38x30x10mm

L6-b x4

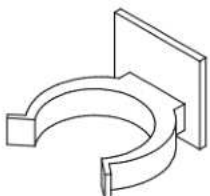

35x32x25mm

W2 x8

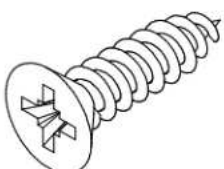

Ø3,5x16mm

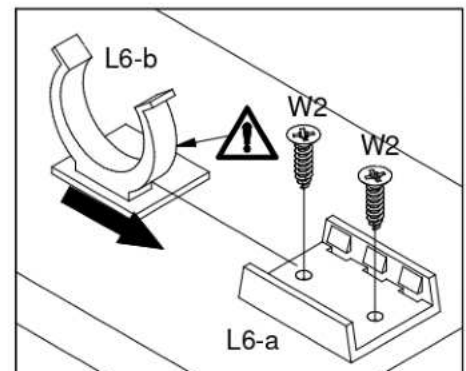

C2

L6-a x2

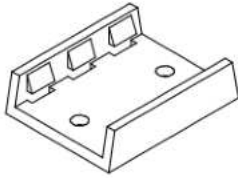

38x30x10mm

L6-b x2

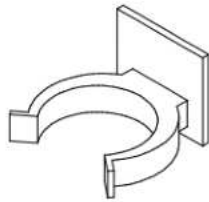

35x32x25mm

W2 x4

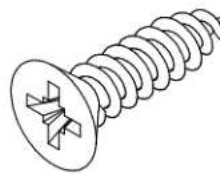

Ø3,5x16mm

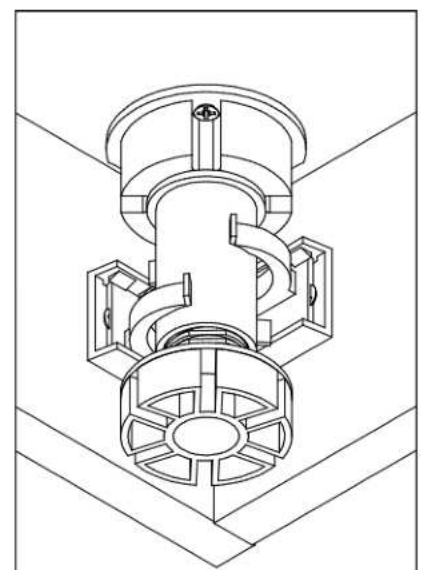
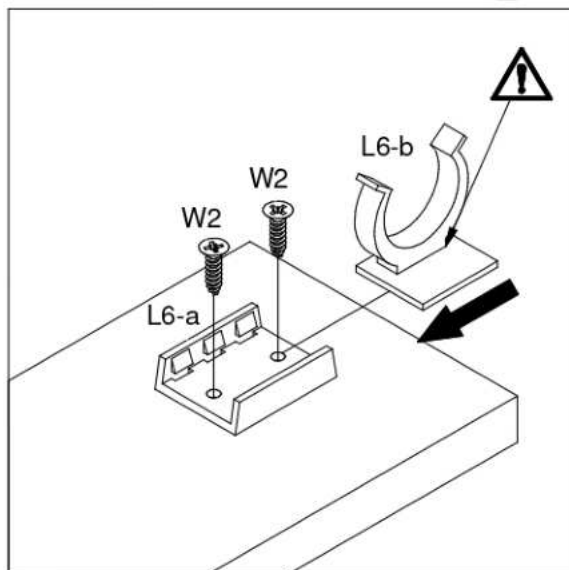
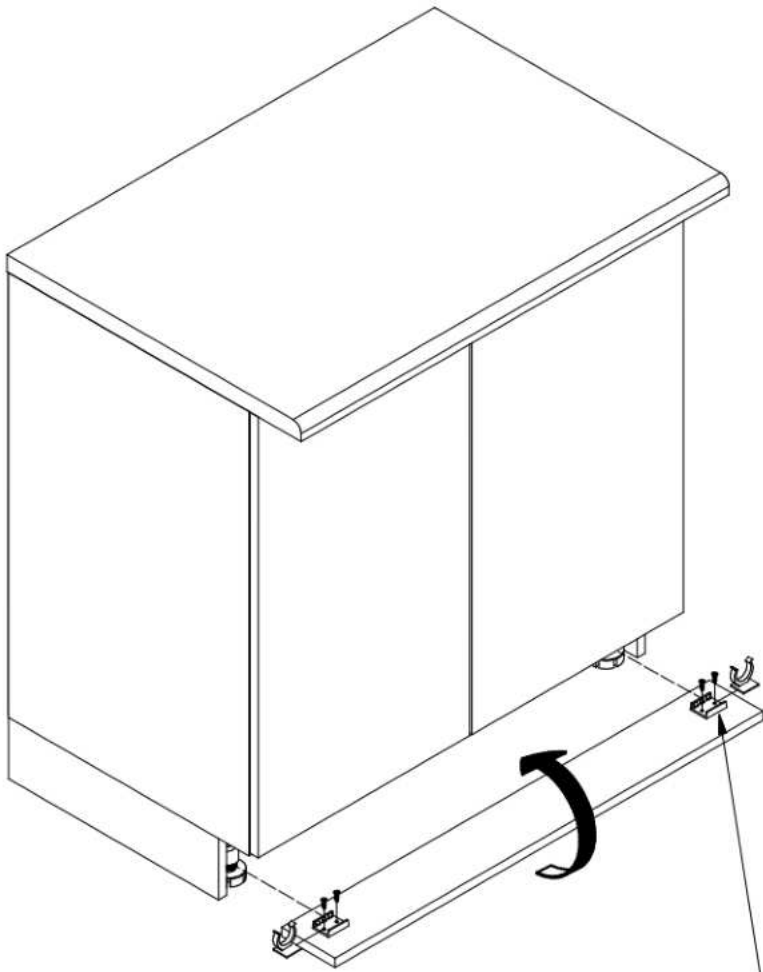
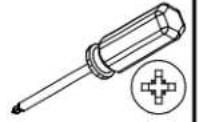





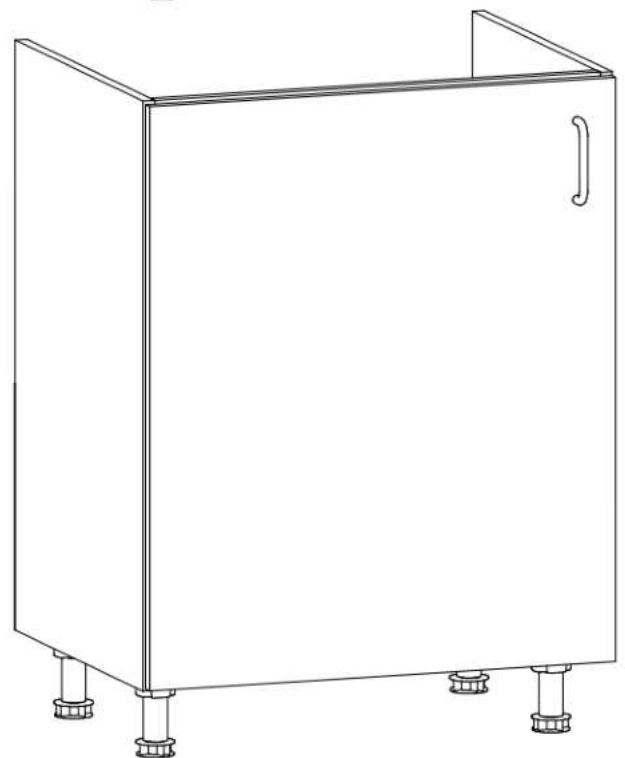
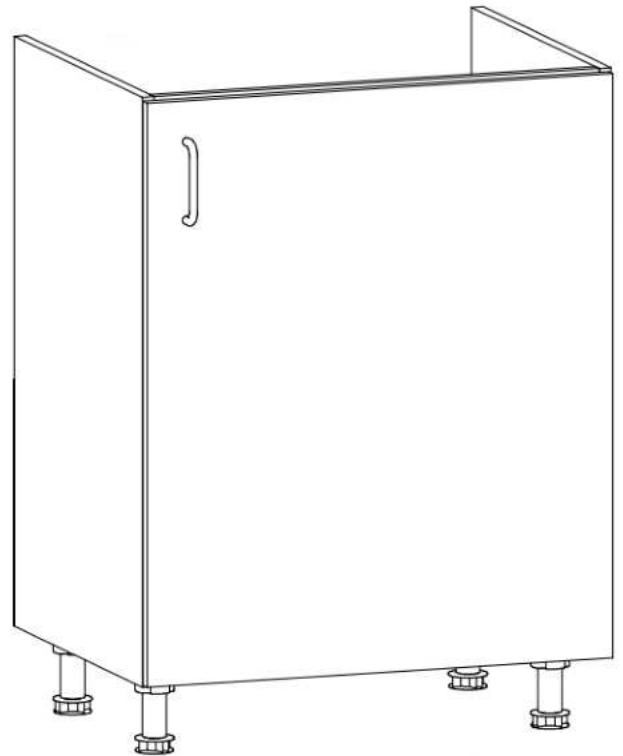
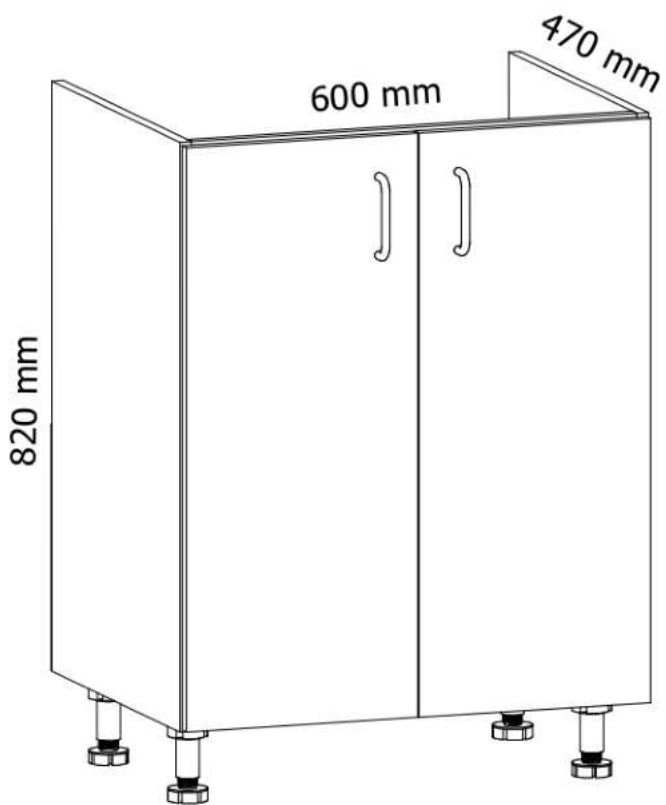

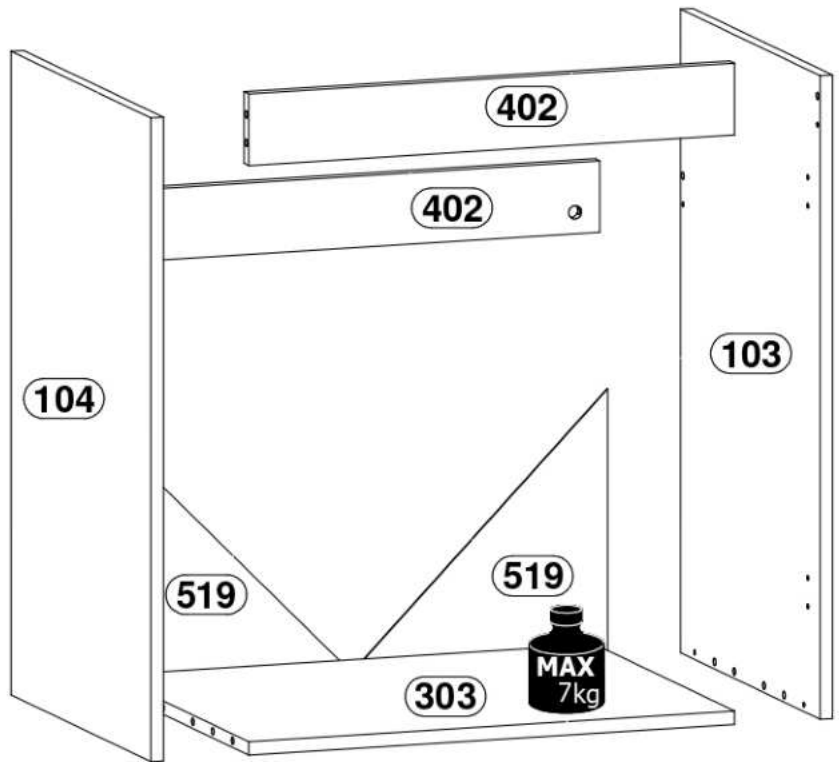
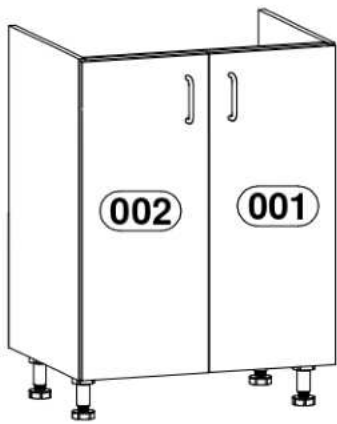
AURORA

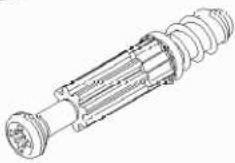
D60Z/D60Z-P/D60Z-L

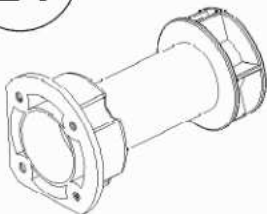

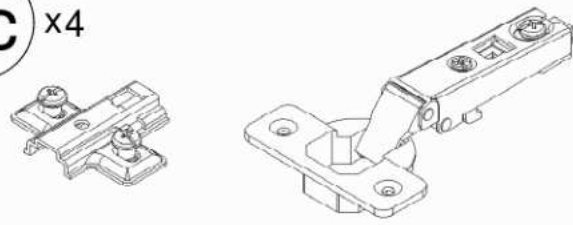

<p>A x12</p>  <p>Ø8x35mm</p>	<p>B x8</p> 	<p>C x8</p>  <p>Ø15x12mm</p>	<p>G x15</p> 
<p>L1 x4</p> 	<p>M x2</p> 	<p>W2 x24</p>  <p>Ø3,5x16mm</p>	<p>Y x8</p>  <p>Ø18 mm</p>
<p>Zc x4</p>  <p>Zc-1 Zc-2</p>			

1

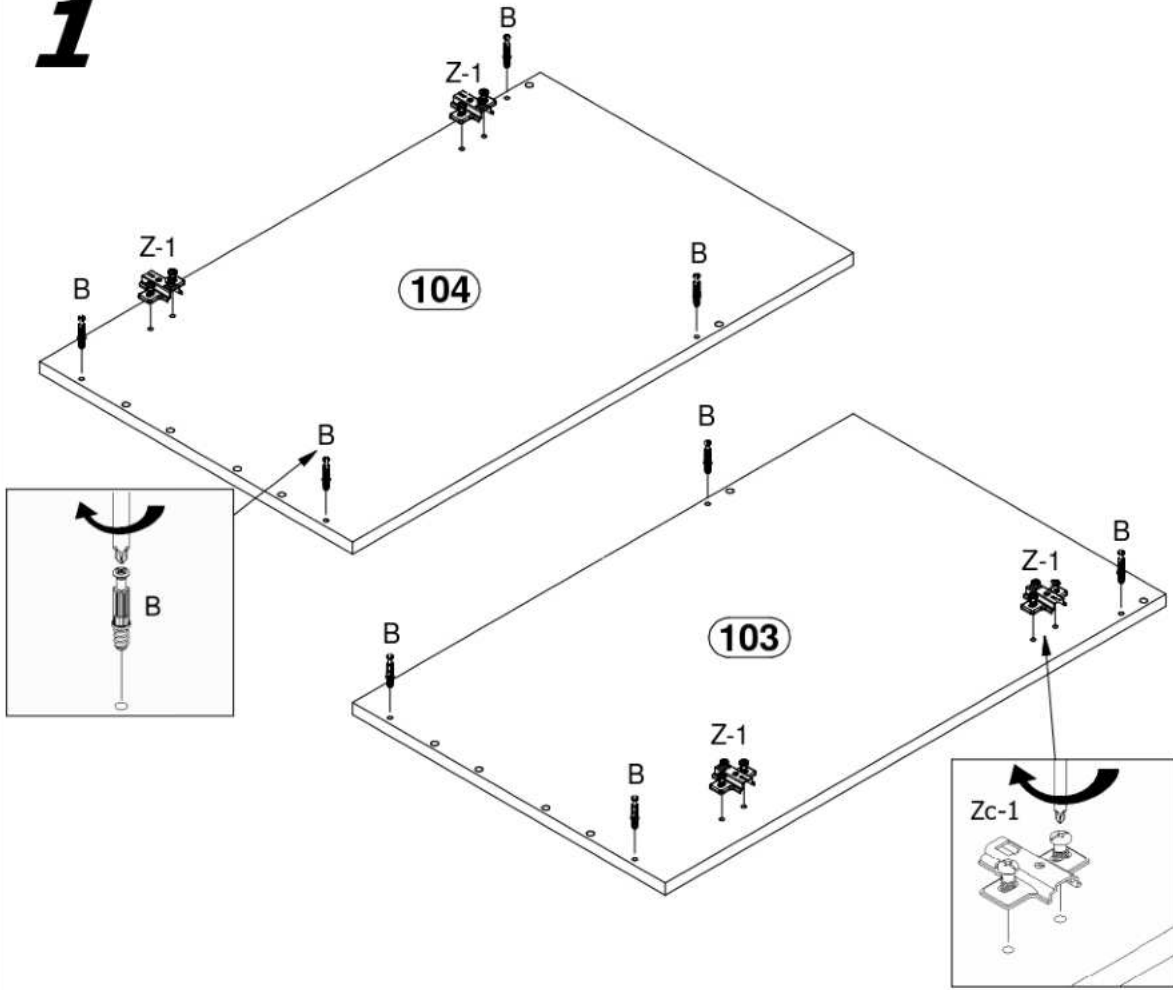

2

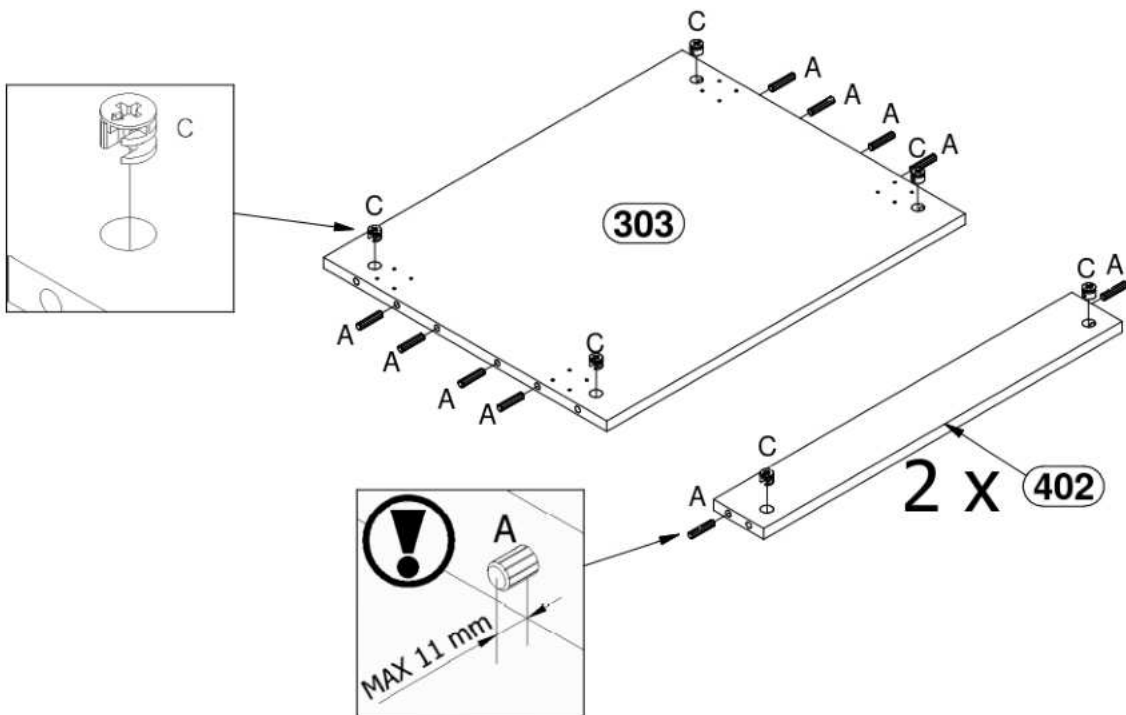

3

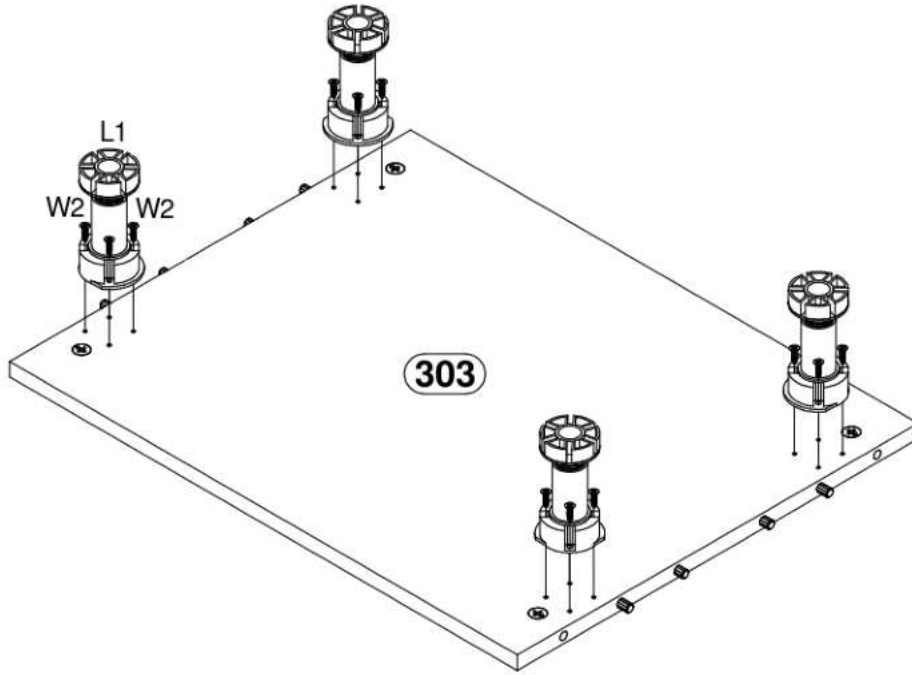

4

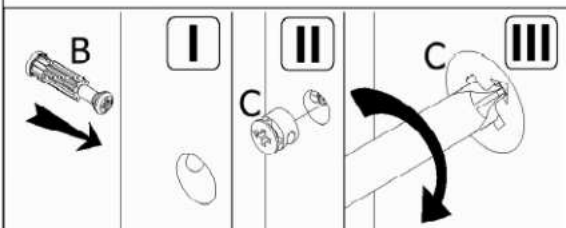
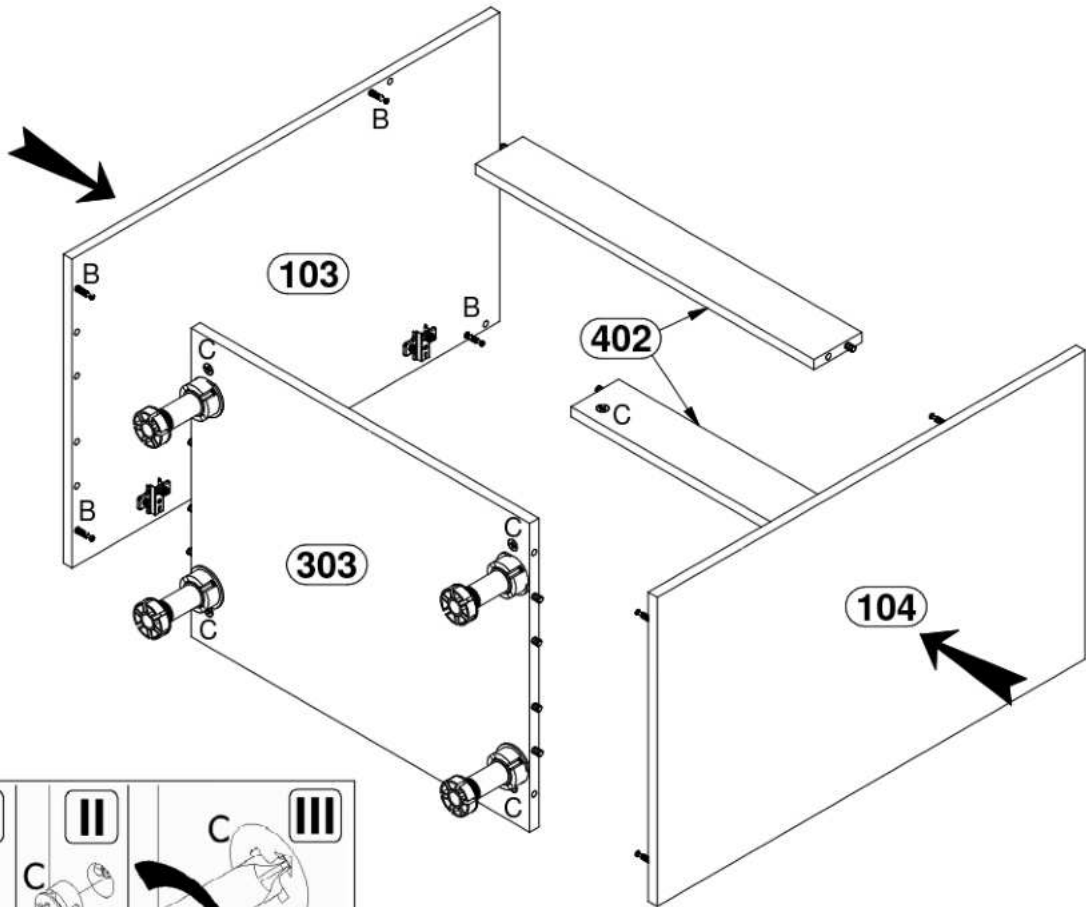

5

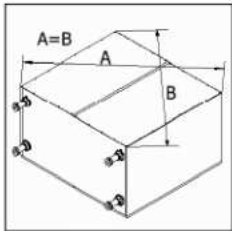
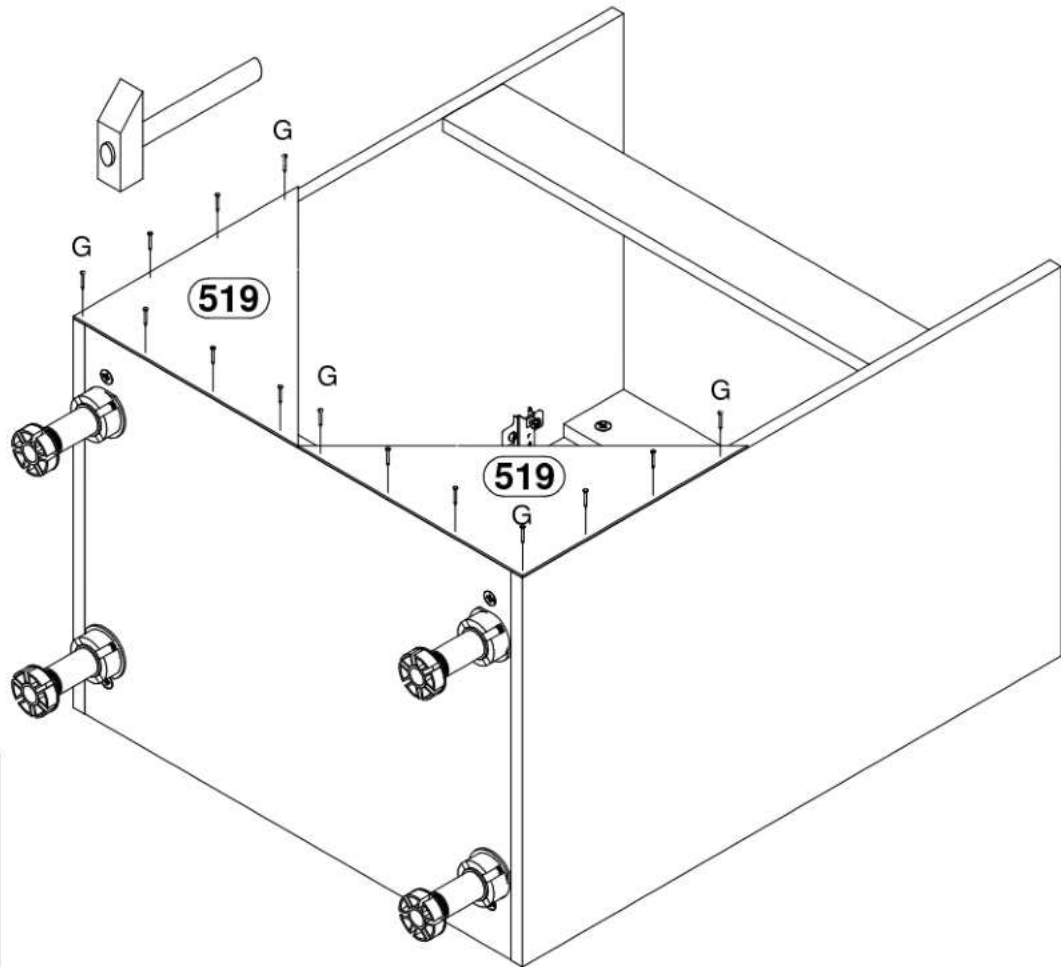

6

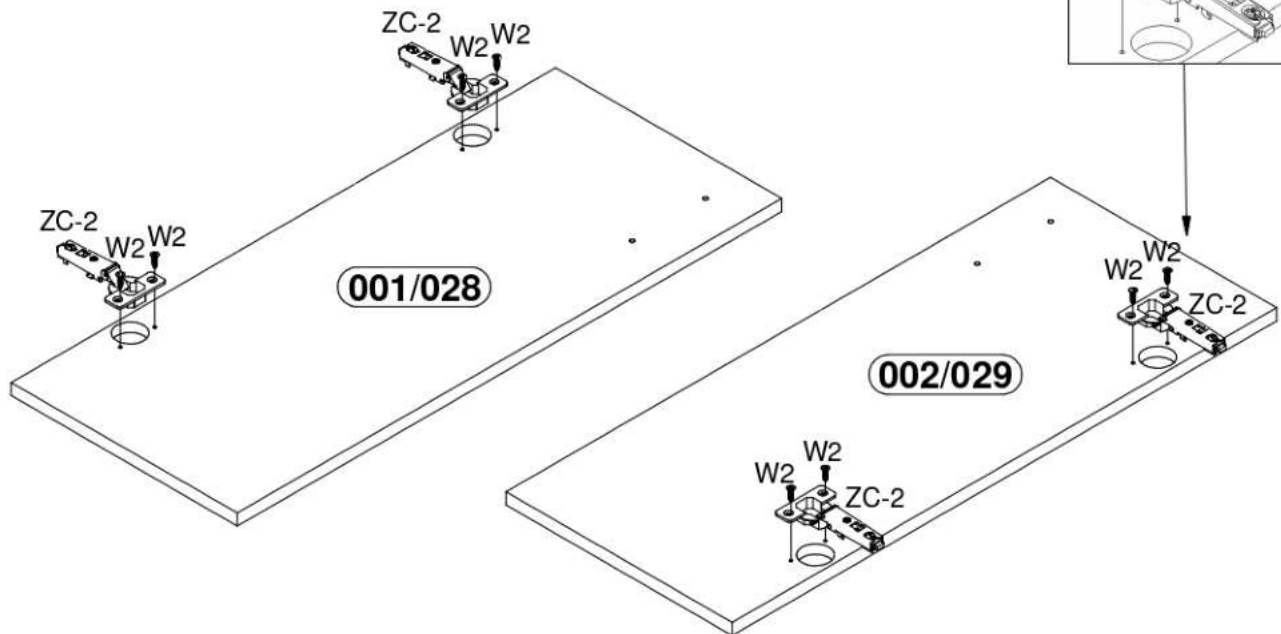

7

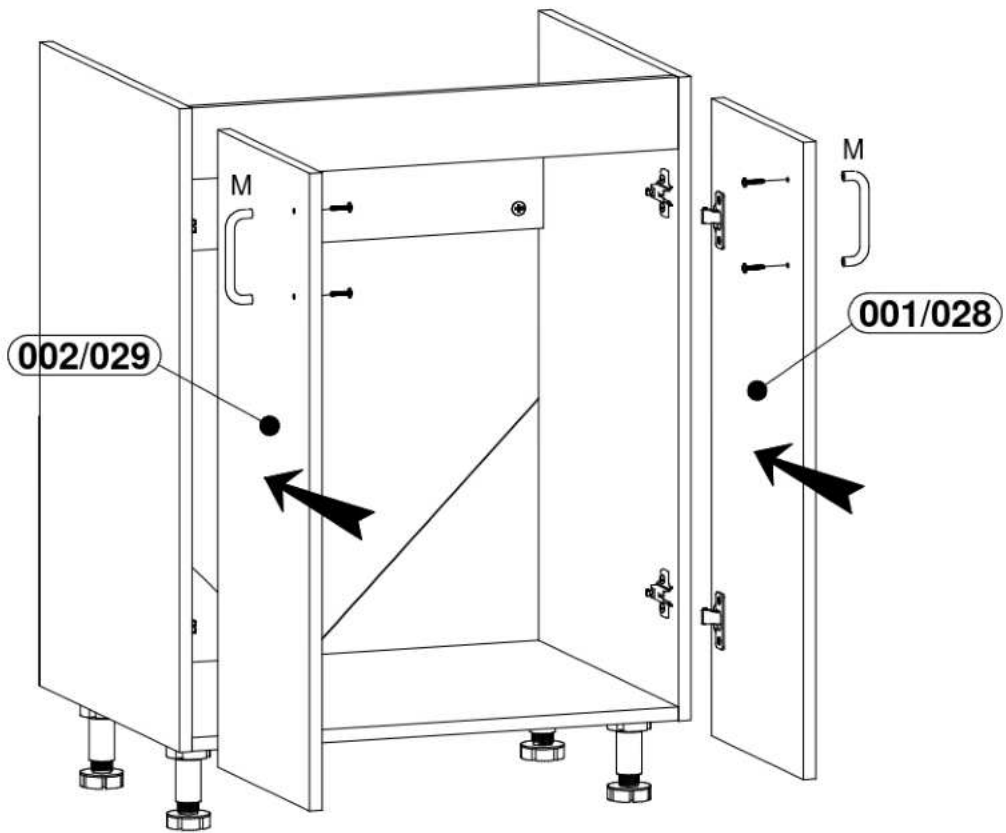

8

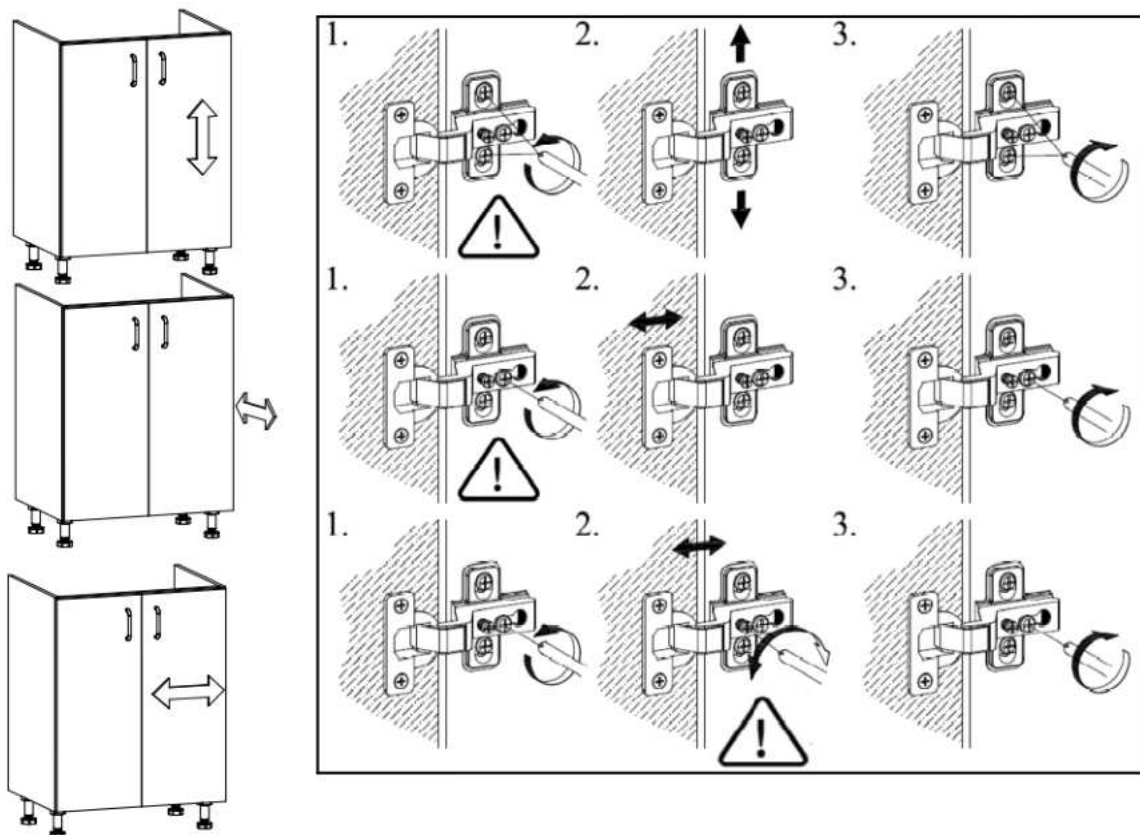

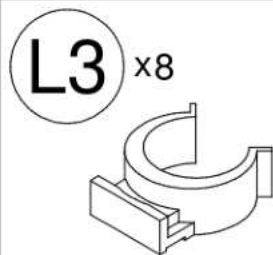
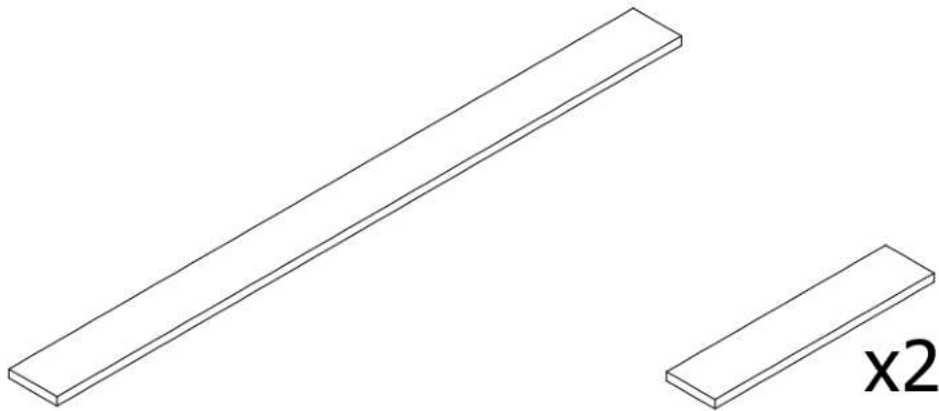
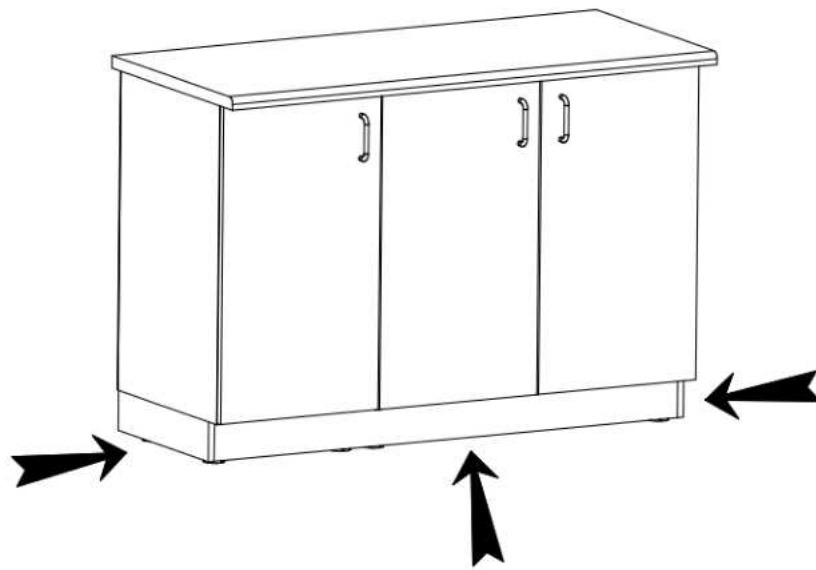

Ø3,5x16

9

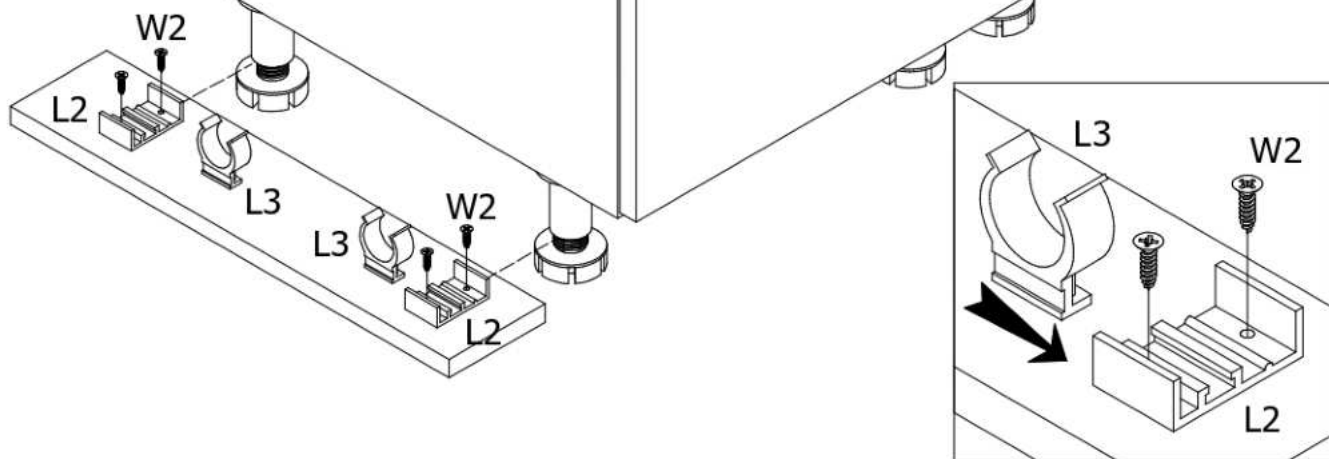

10

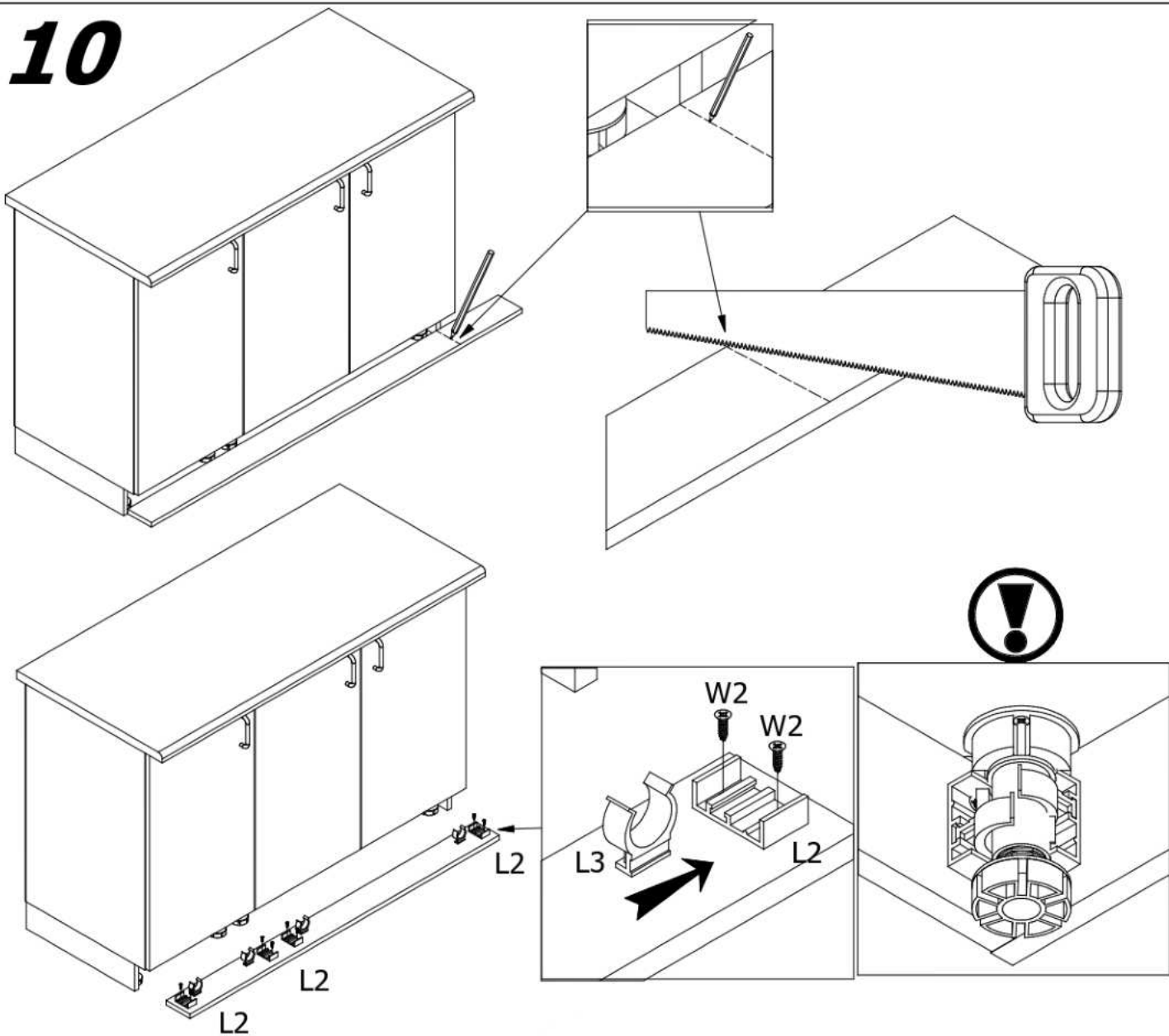





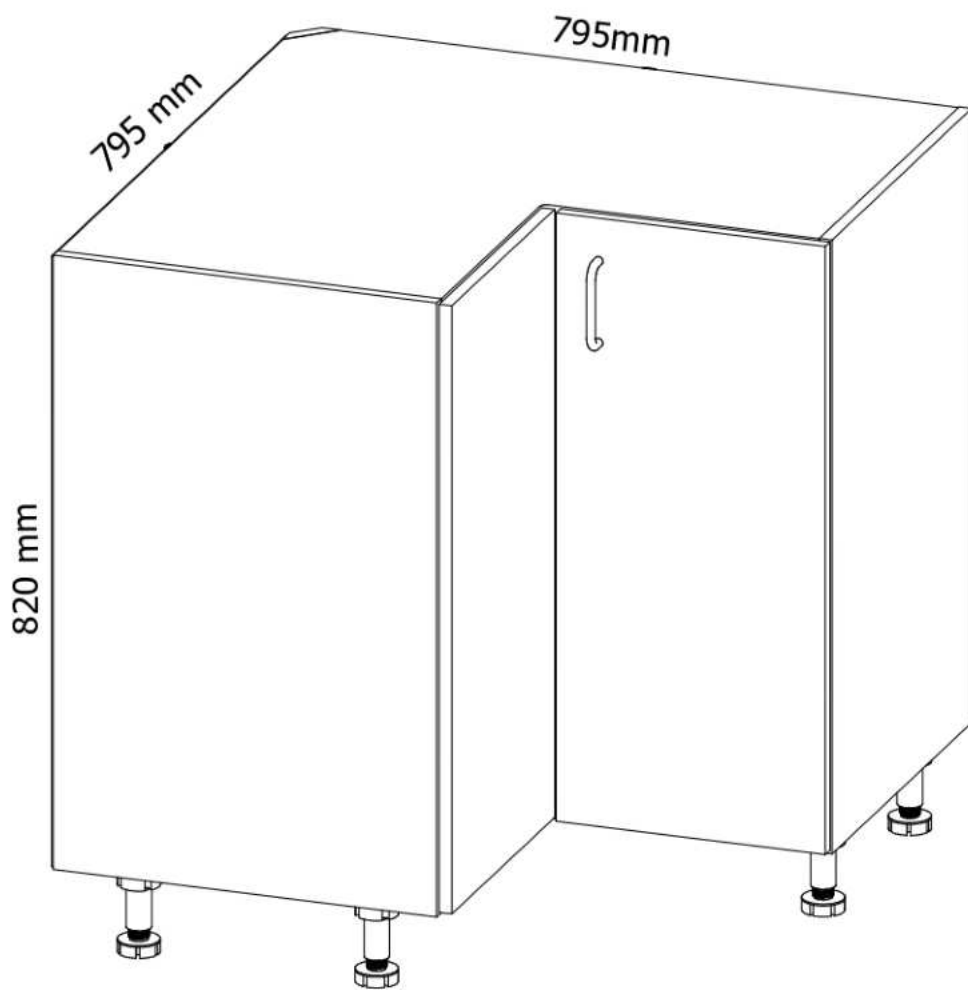

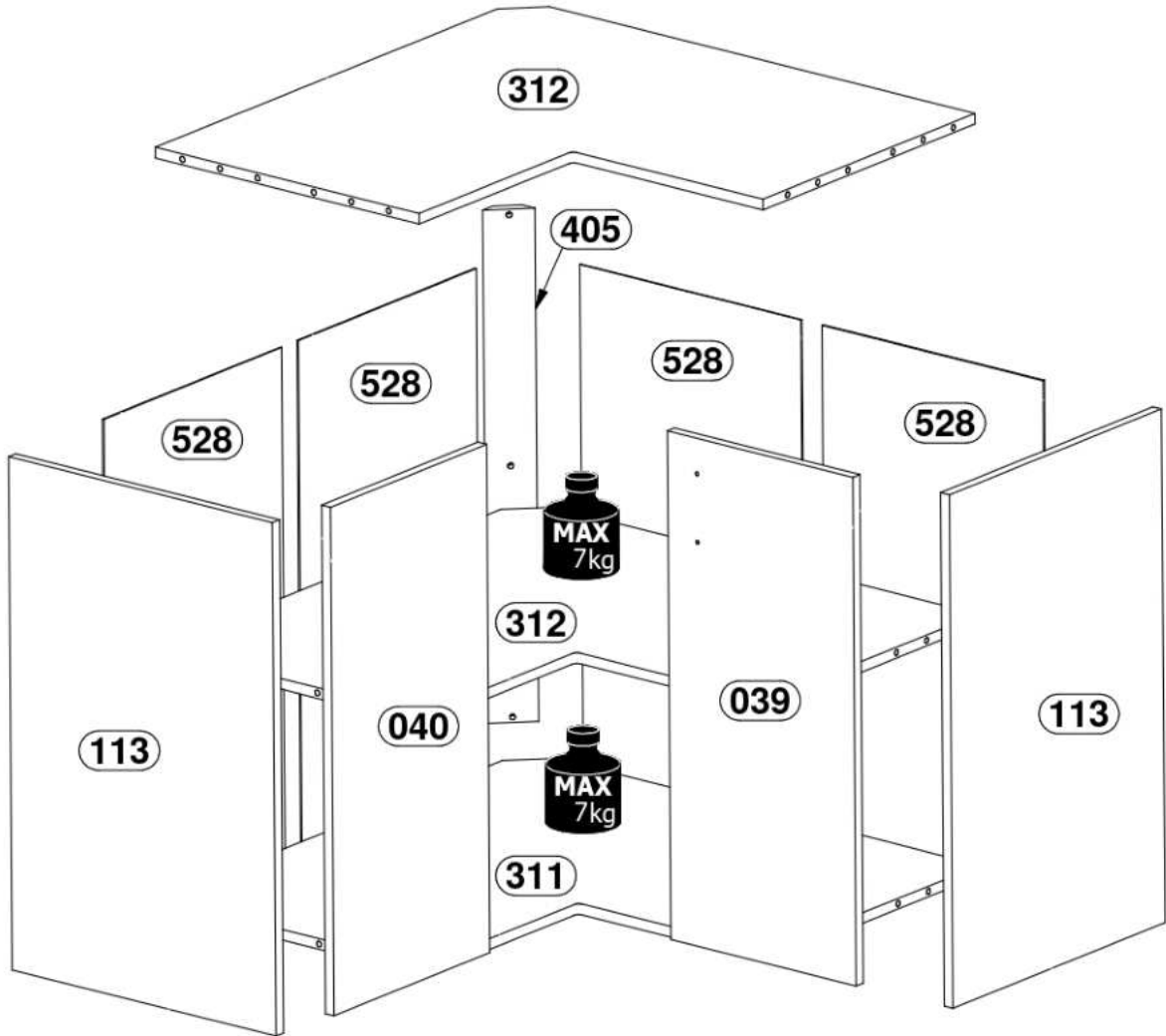
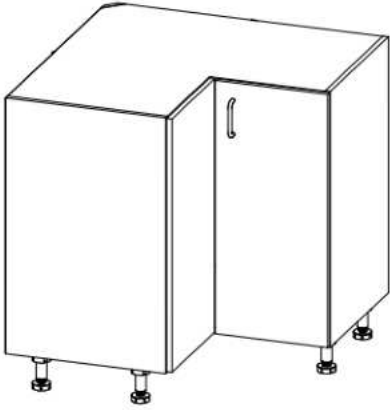

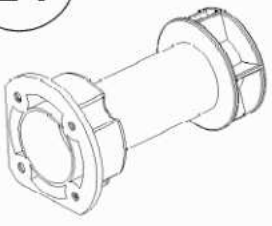
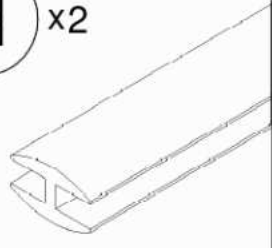

AURORA

D90N



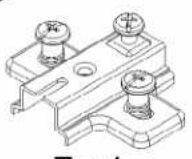

<p>A x24</p>  <p>Ø8x35mm</p>	<p>B x12</p> 	<p>C x12</p>  <p>Ø15x12mm</p>	<p>D x3</p>  <p>Ø6,4x50 mm</p>
<p>G x45</p> 	<p>L1 x5</p> 	<p>H x2</p>  <p>715 mm</p>	<p>M x1</p> 
<p>W2 x28</p>  <p>Ø3,5x16mm</p>	<p>Y x12</p>  <p>Ø18 mm</p>	<p>Y1 x3</p> 	
<p>Zg x4</p>  <p>Zg-1</p>  <p>Zg-2</p>			

1

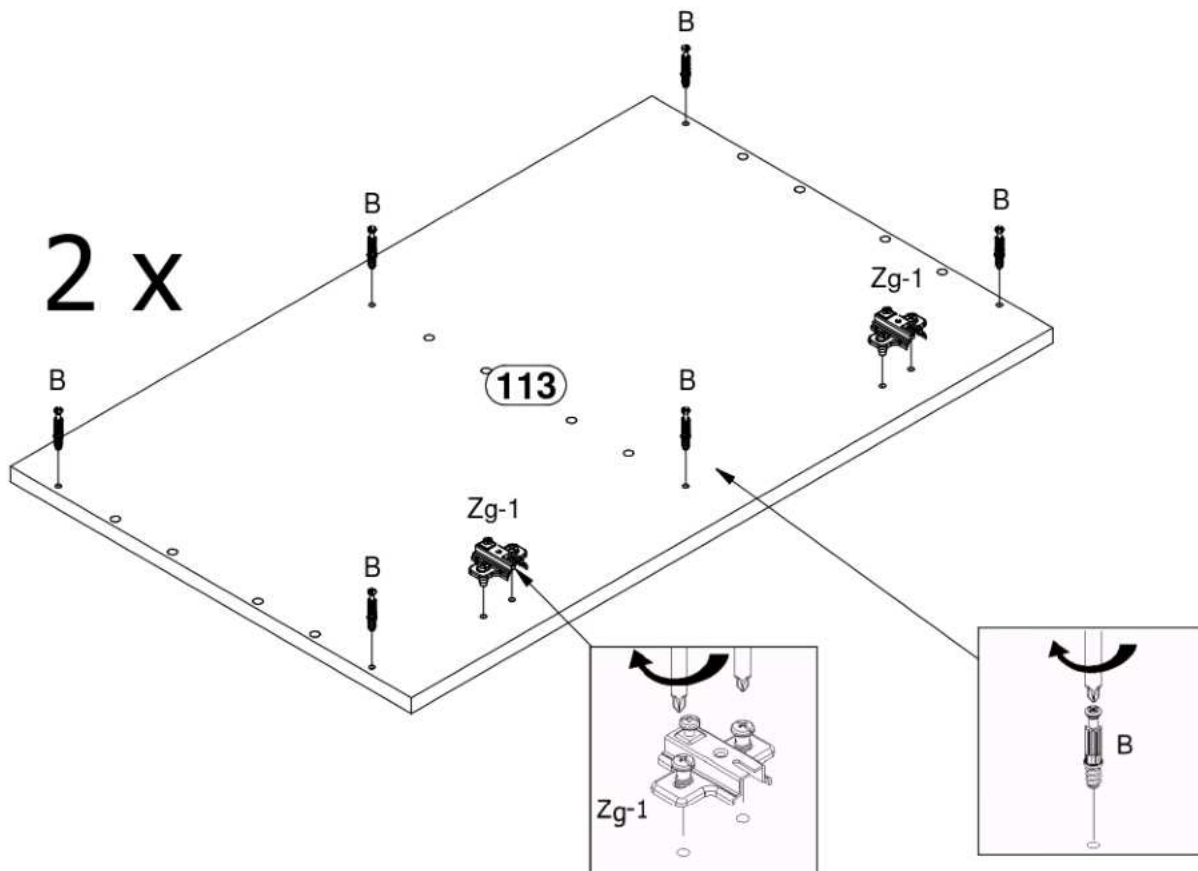

2

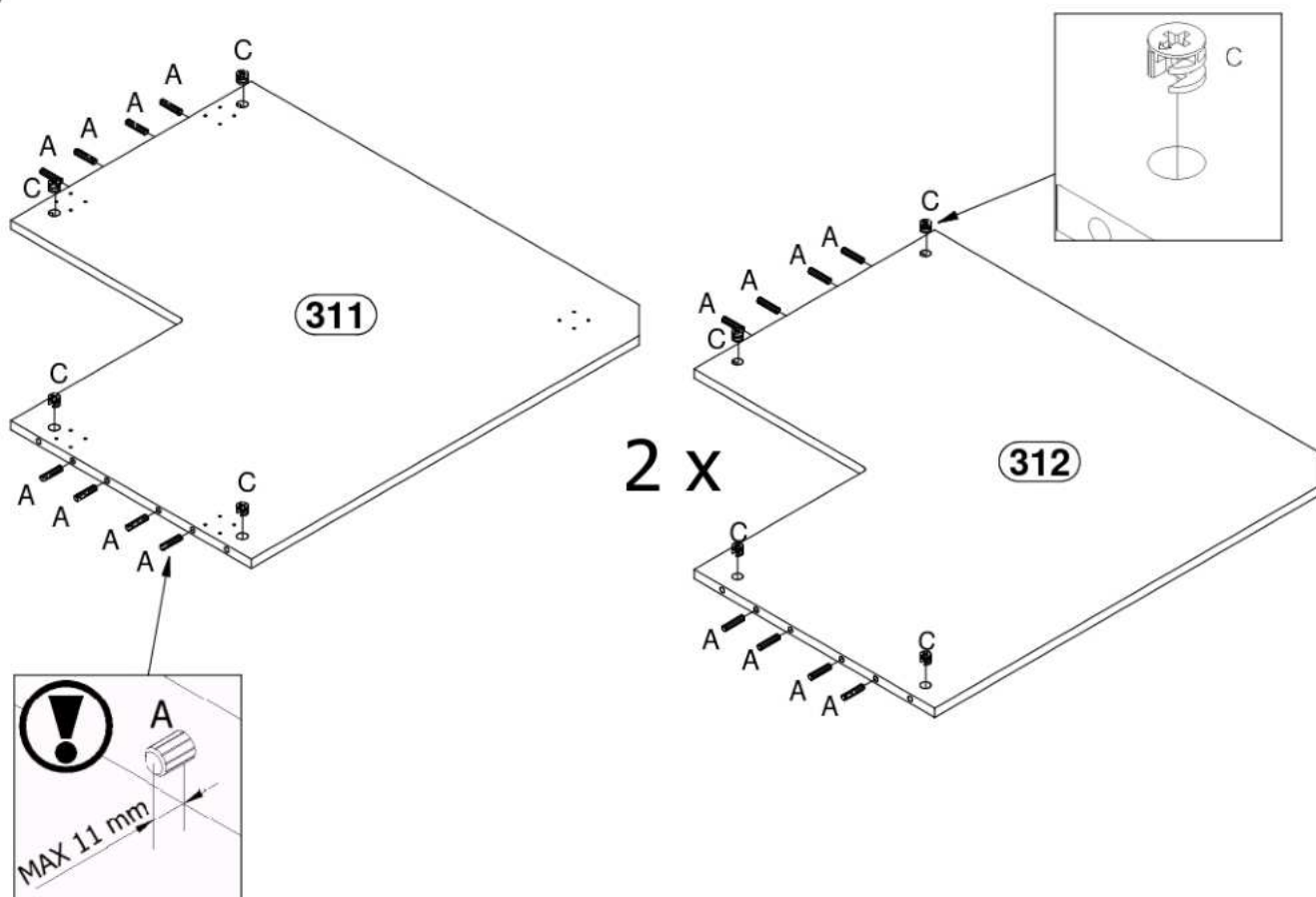

3

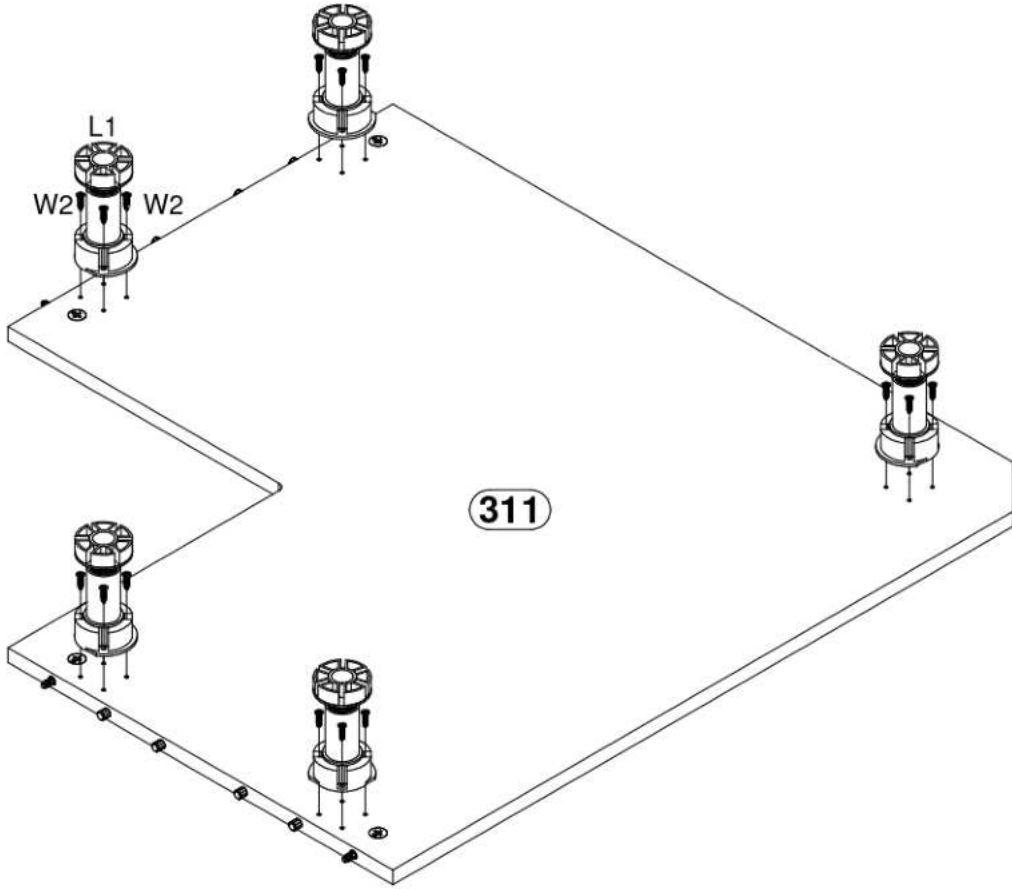

4

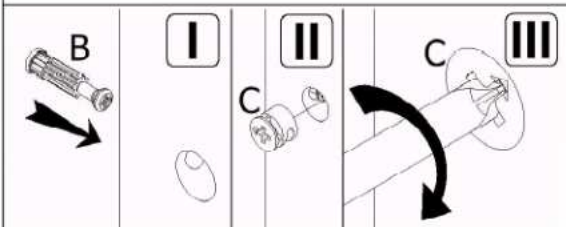
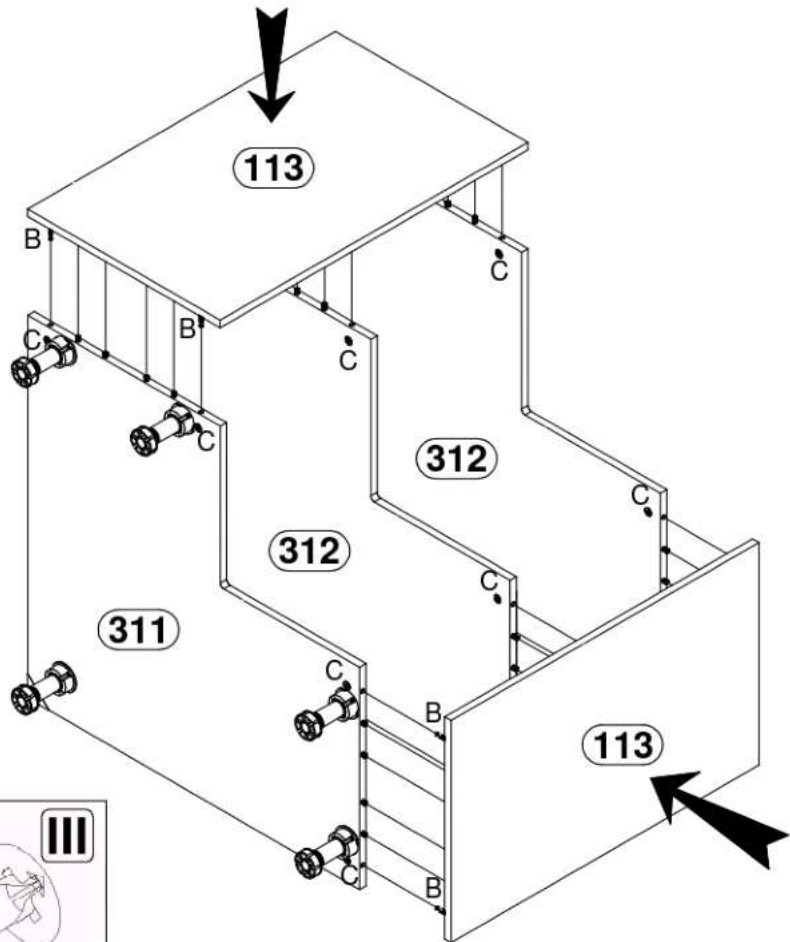

5

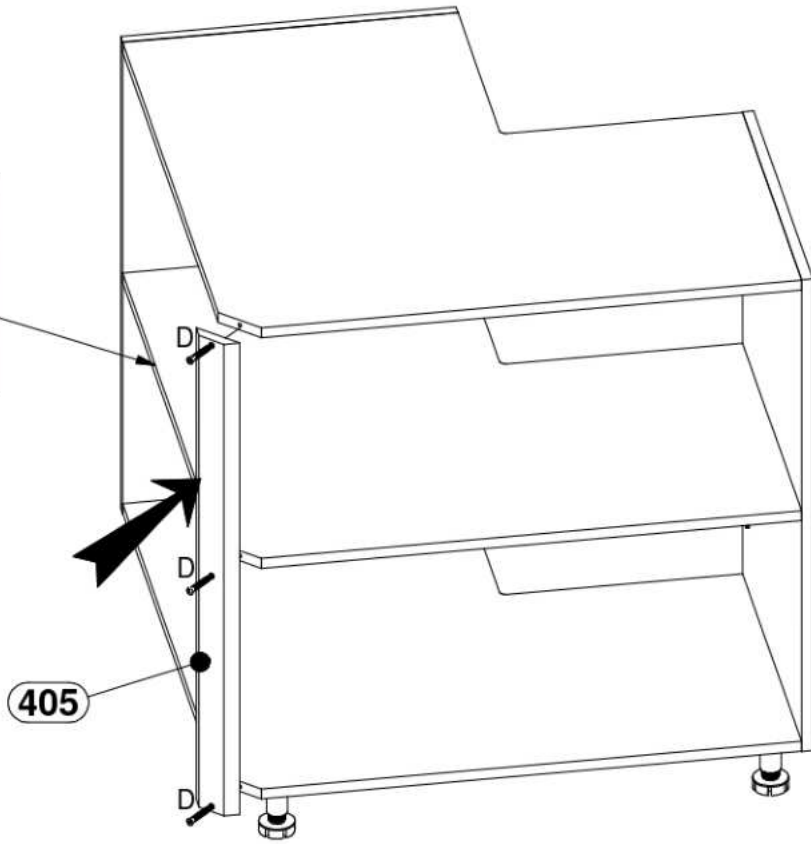
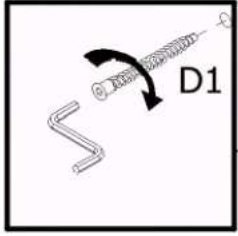

6

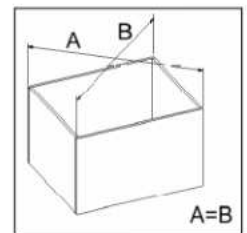
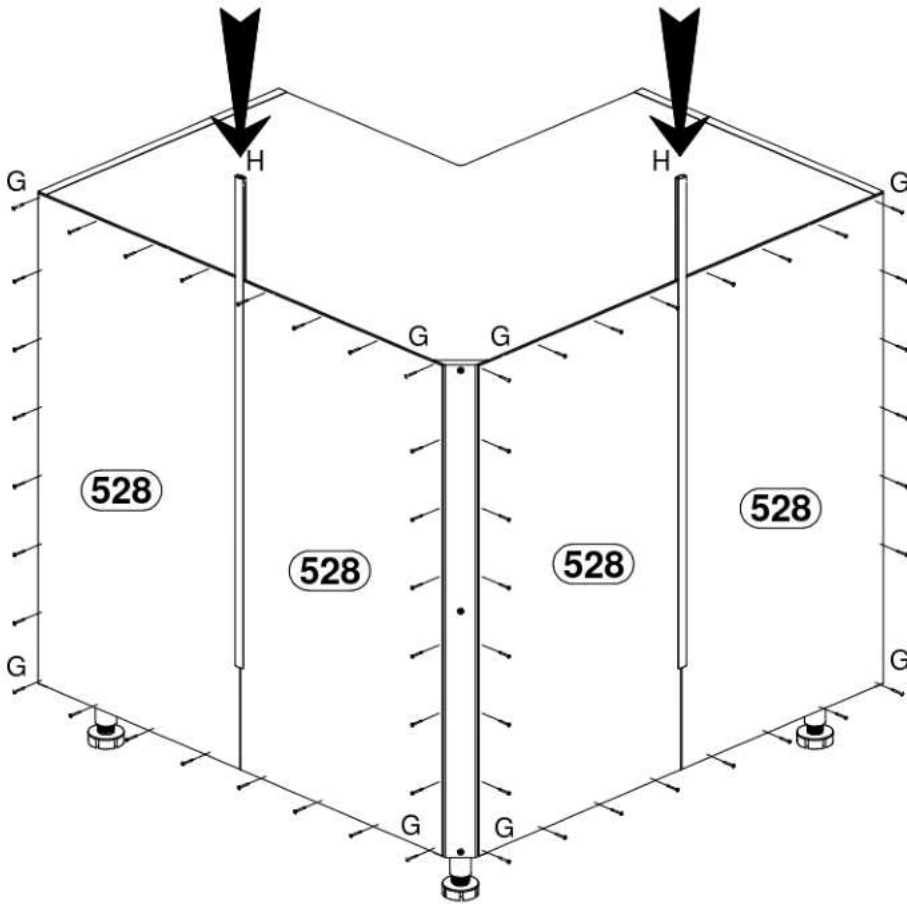

7

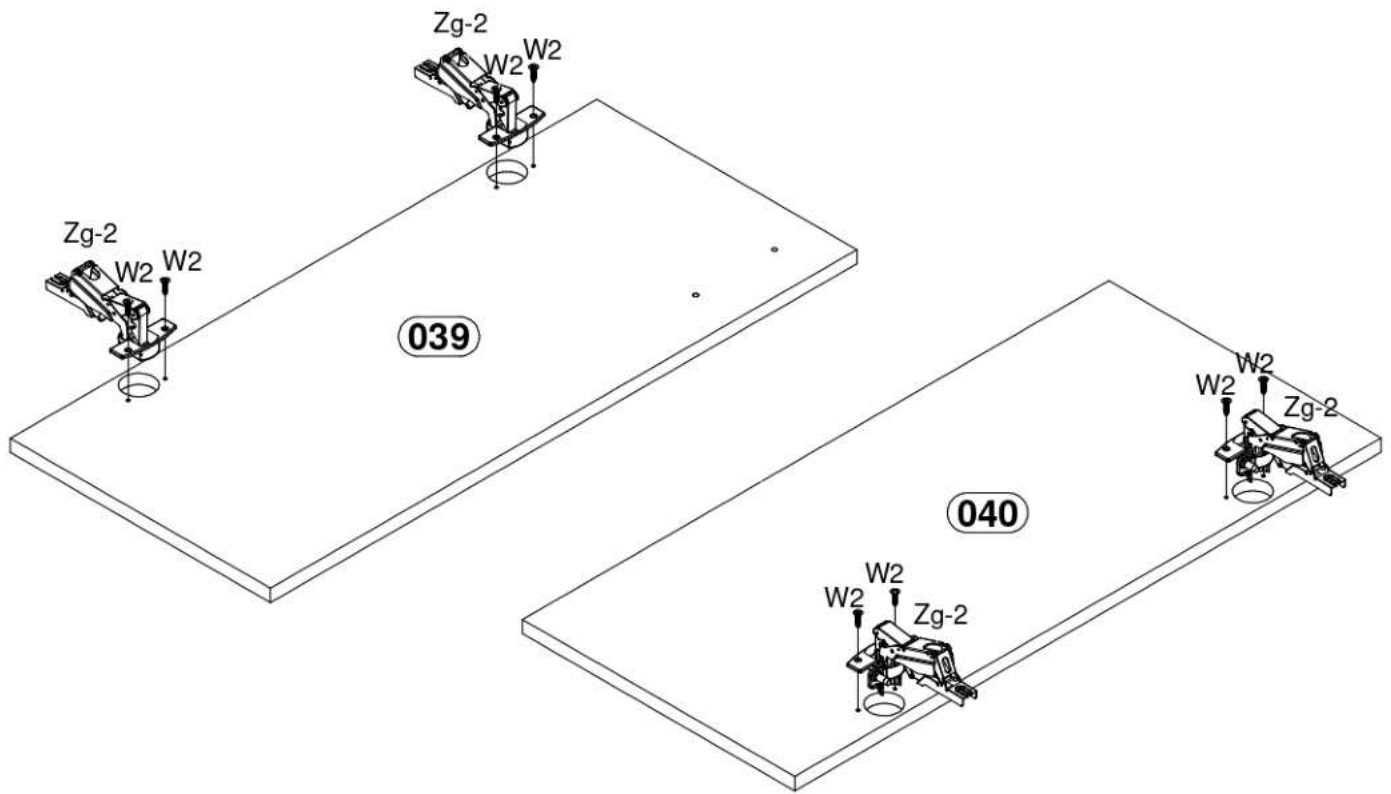

8

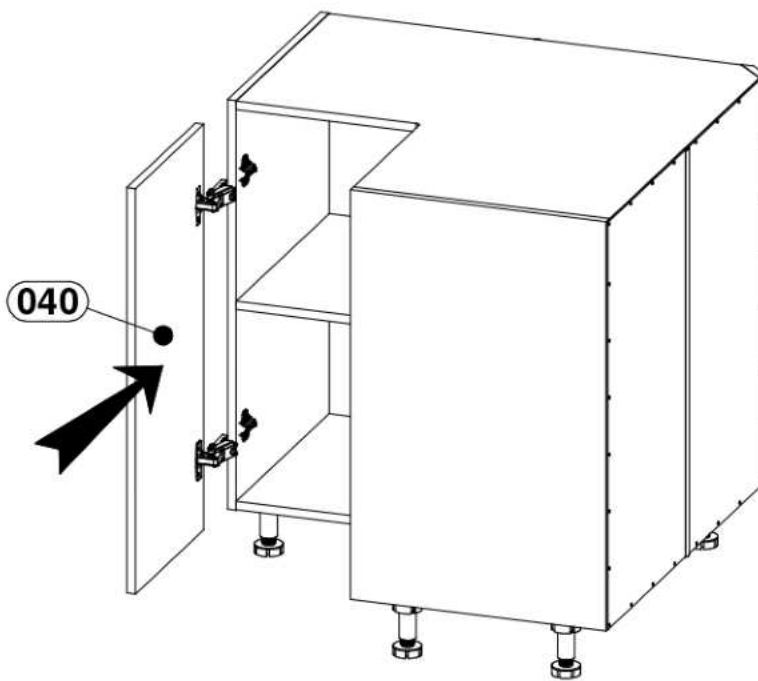

9

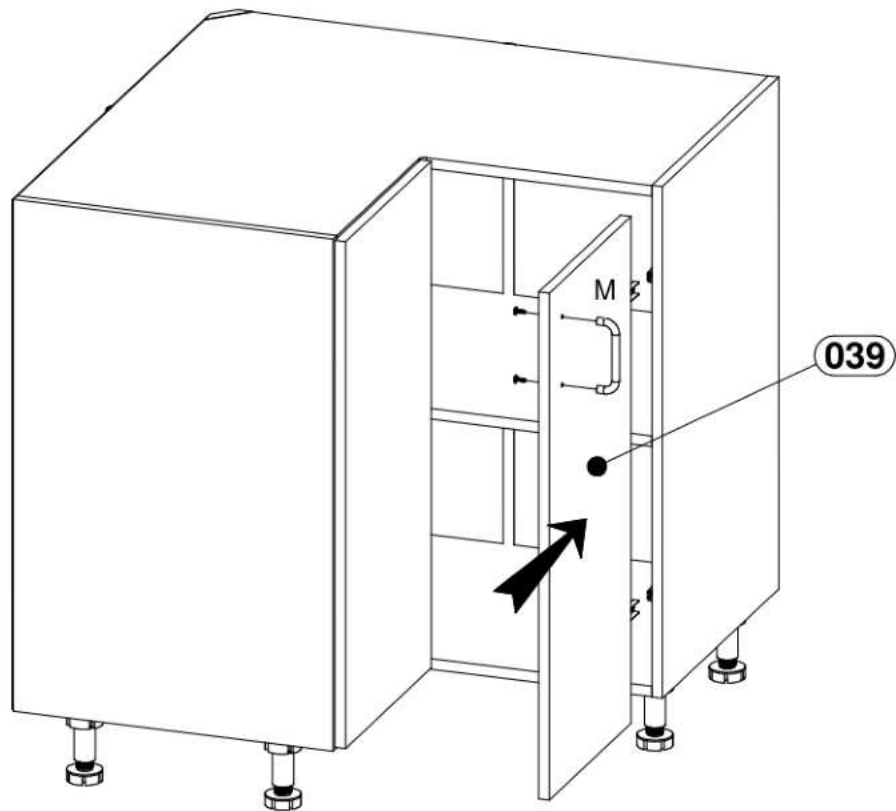

10

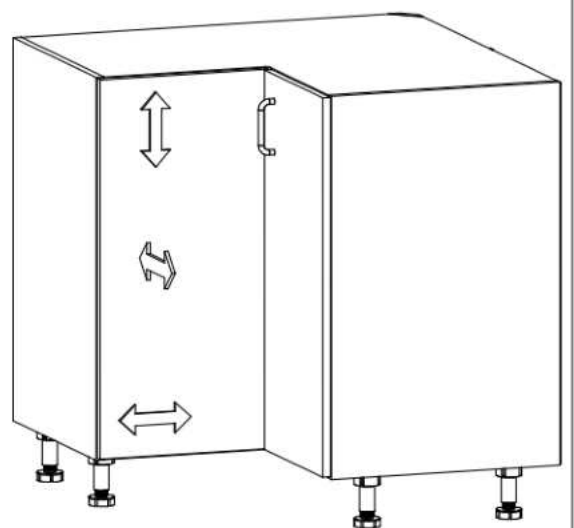
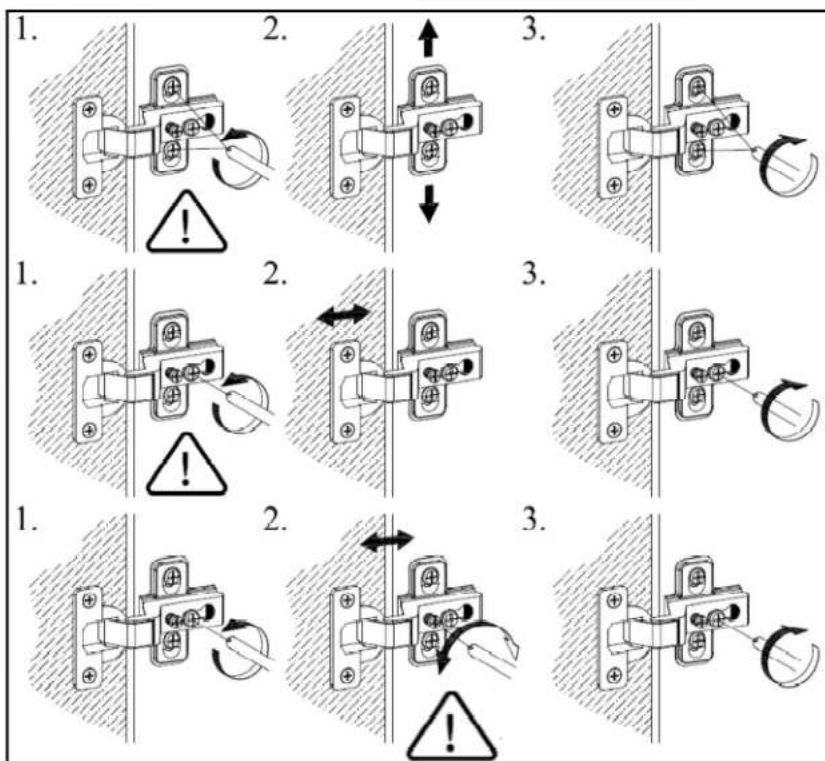

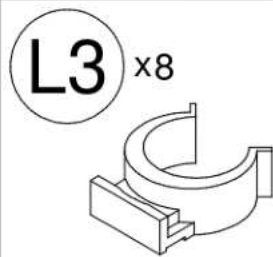
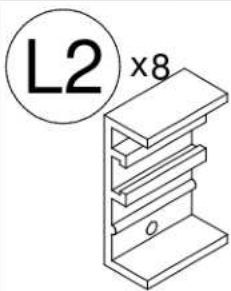
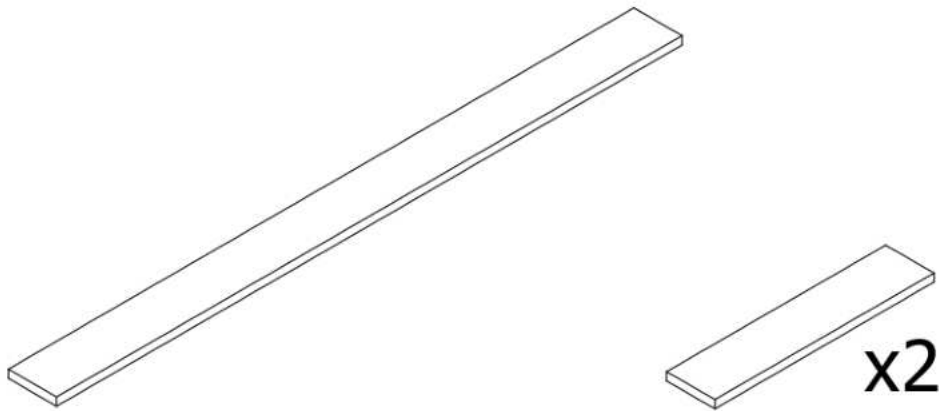
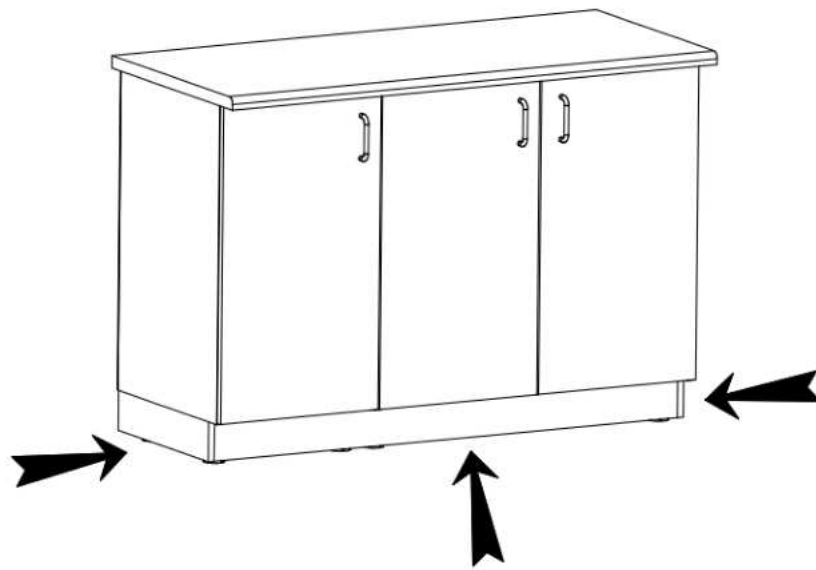

Ø3,5x16

11

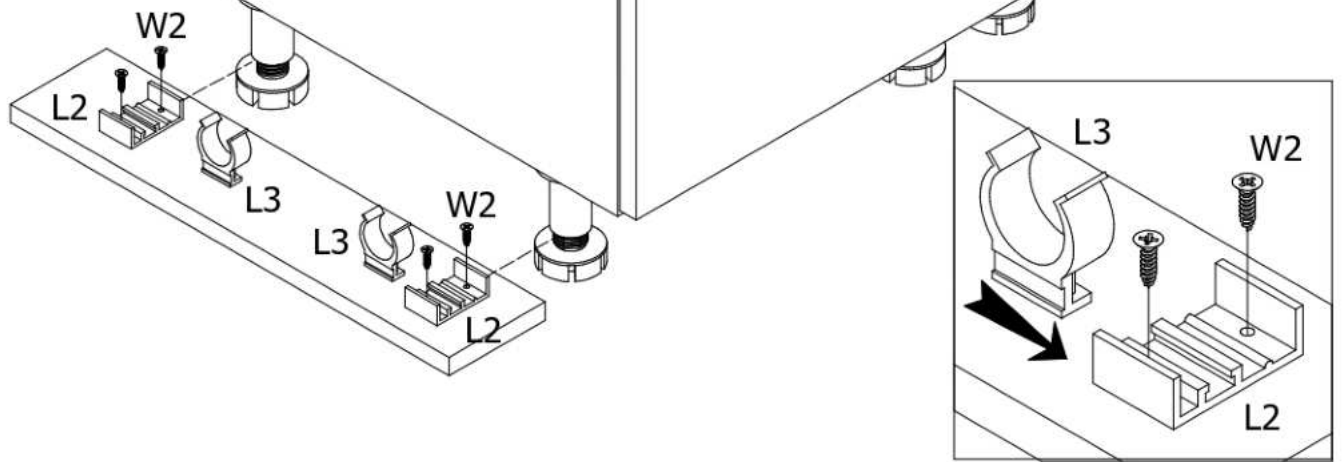

12

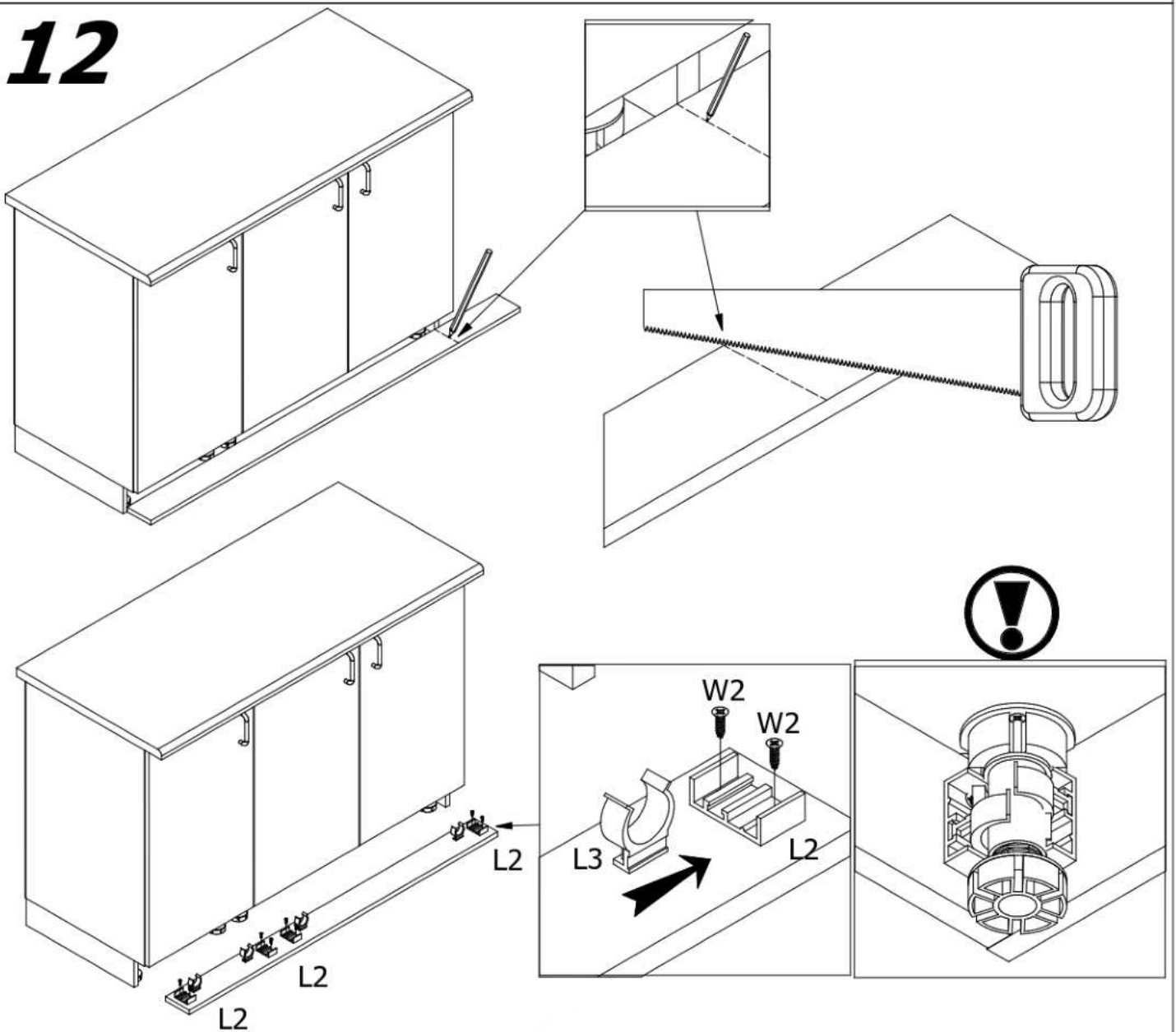





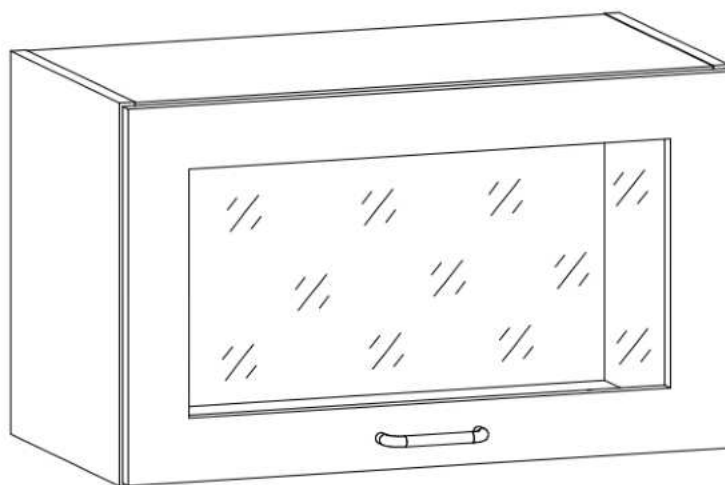
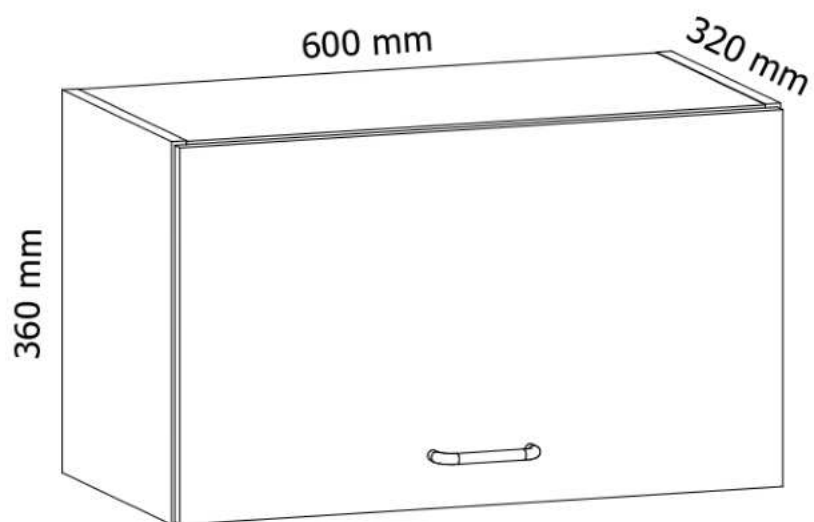

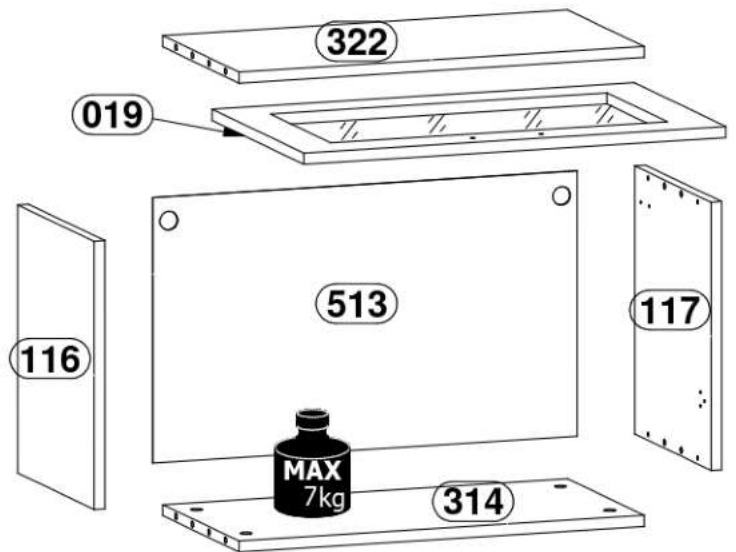
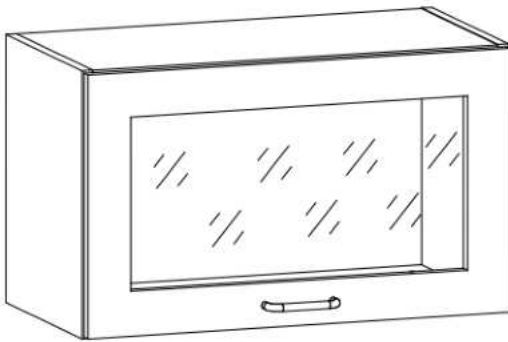
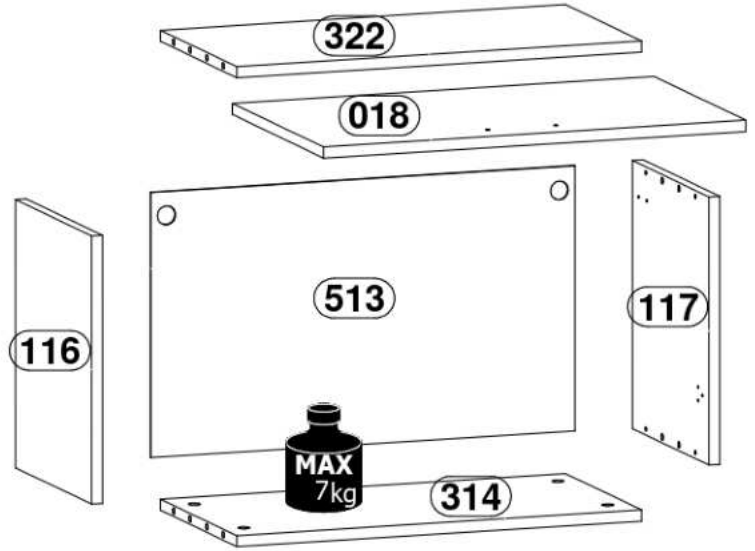
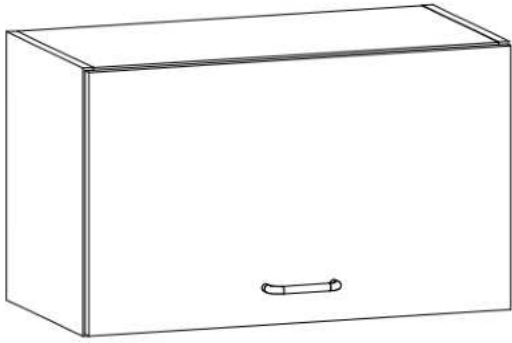



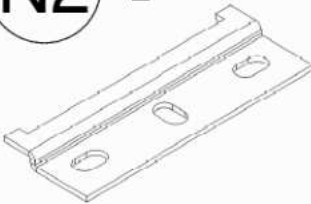
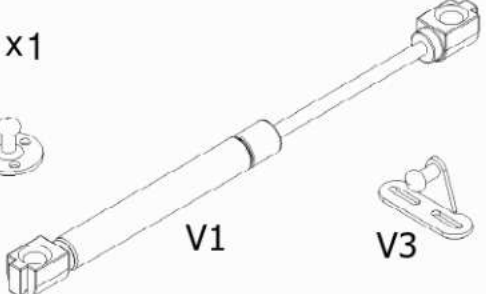

AURORA

G60KN



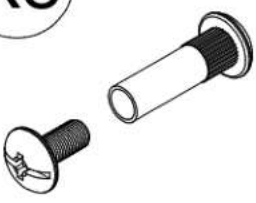

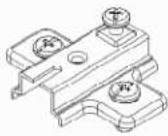
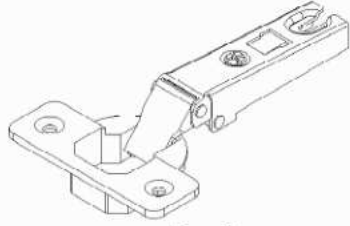
<p>A x8</p>  <p>Ø8x35mm</p>	<p>B x8</p> 	<p>C x8</p>  <p>Ø15x12mm</p>	<p>G x20</p> 
<p>M x1</p> 	<p>N1 x2</p> 	<p>N2 x2</p> 	
<p>V x1</p>  <p>V1</p> <p>V2</p>  <p>V3</p> 	<p>W2 x4</p>  <p>Ø3,5x16mm</p>	<p>W8 x4</p>  <p>Ø4x30mm</p>	
<p>X8 x2</p> 	<p>Y x8</p>  <p>Ø18 mm</p>	<p>Zn x2</p>  <p>Zn-1</p>  <p>Zn-2</p>	

1

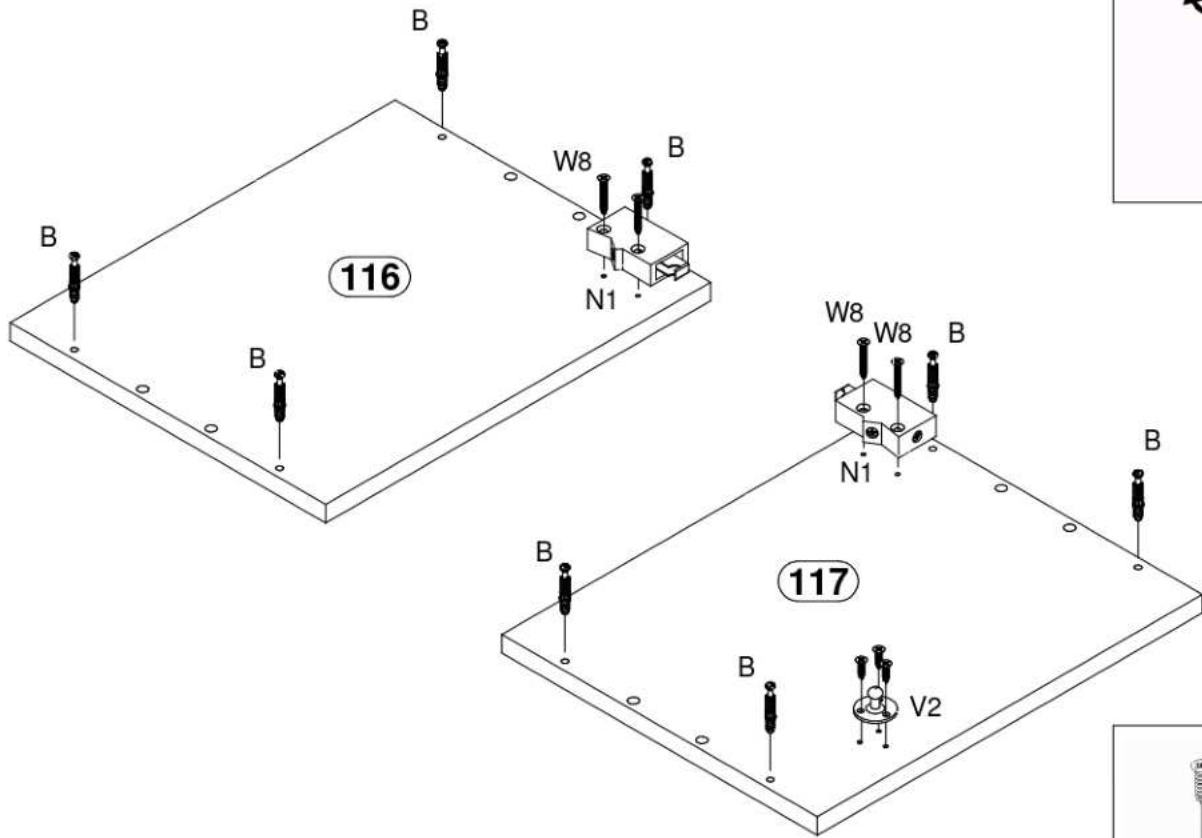

2

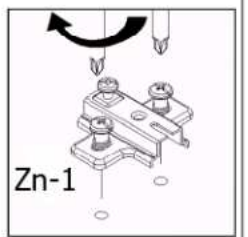
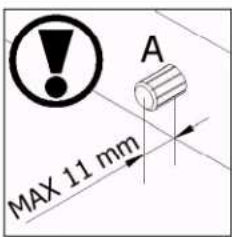
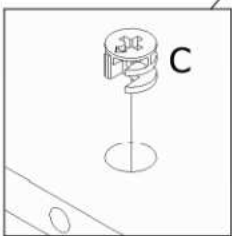
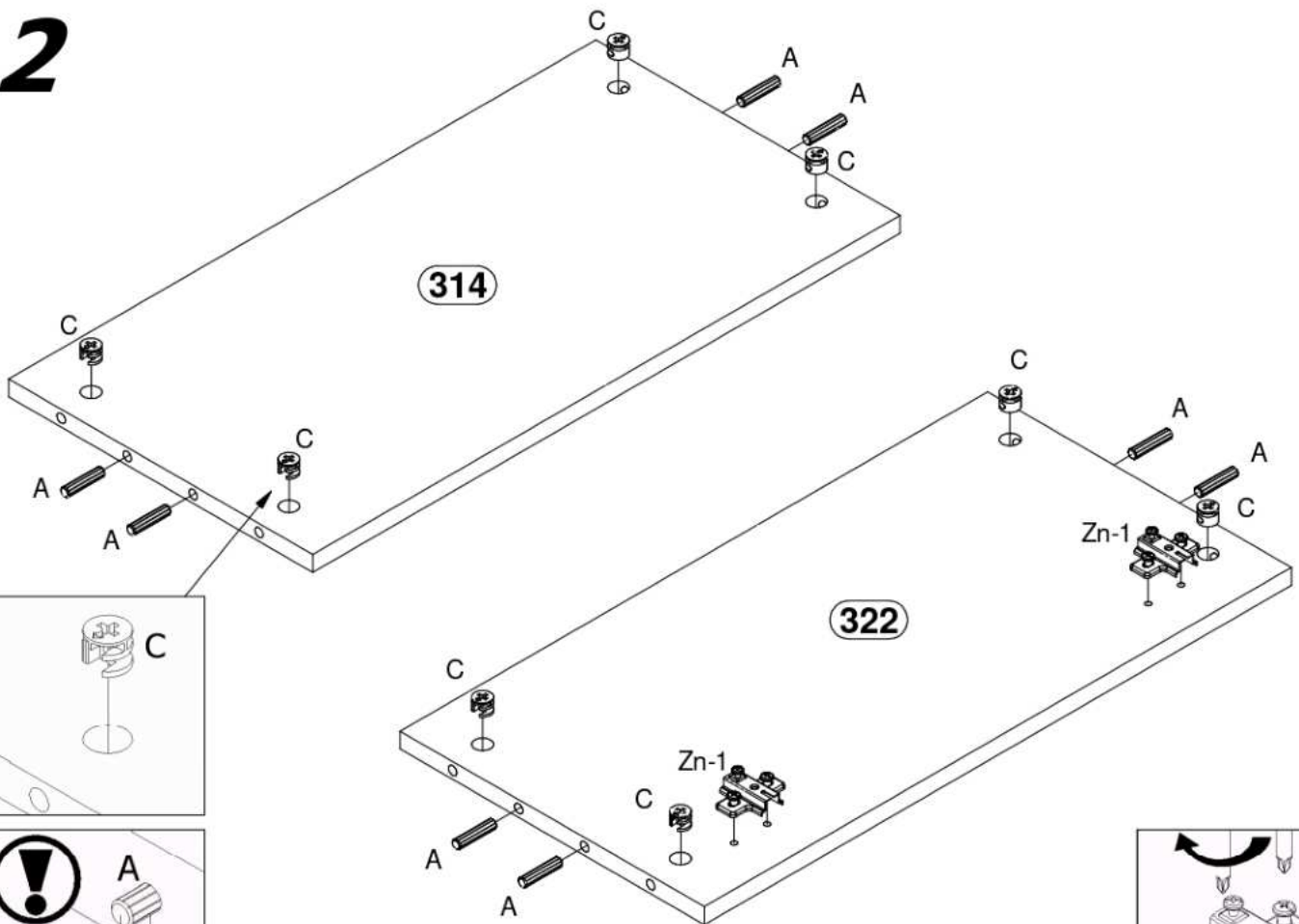

3

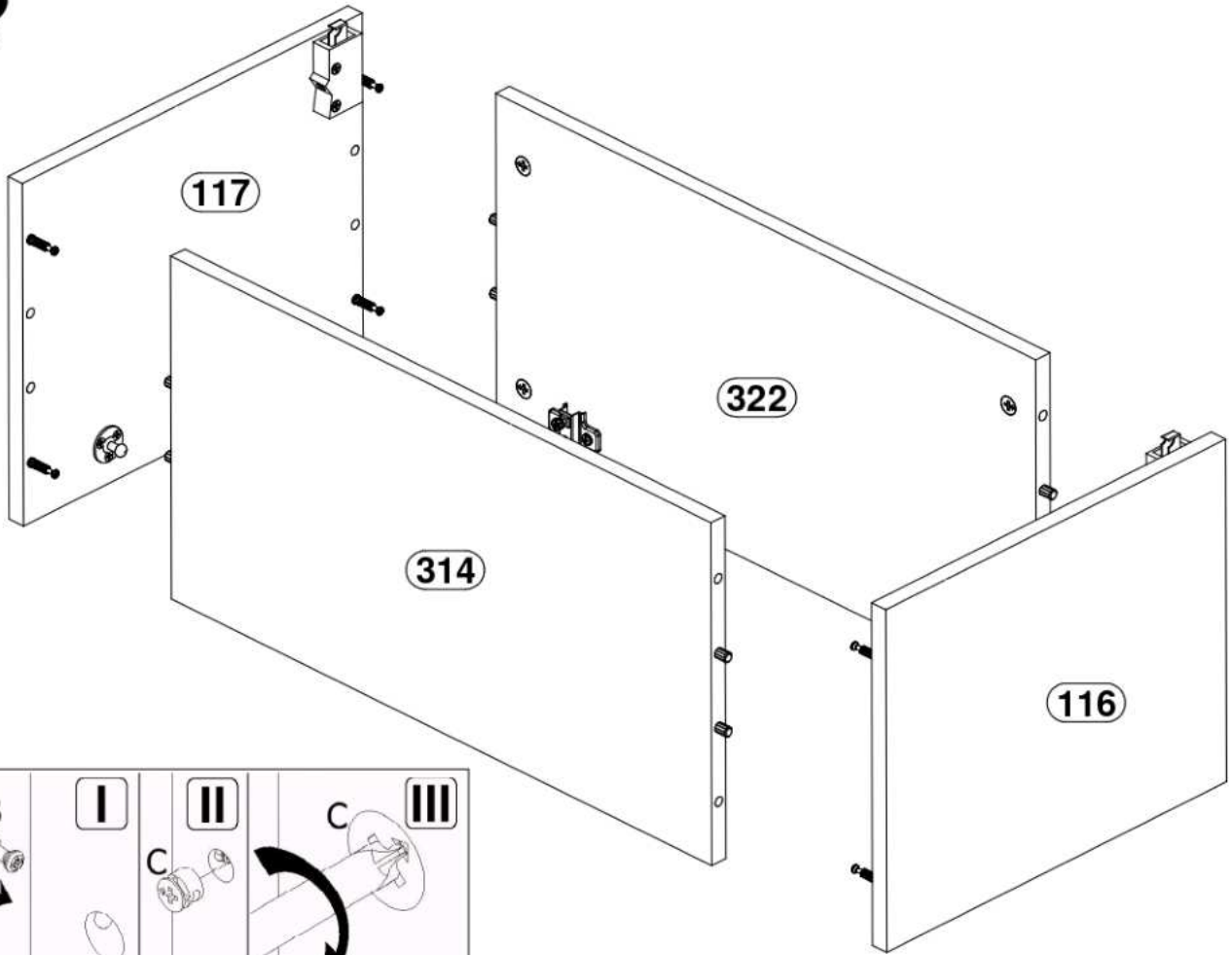

4

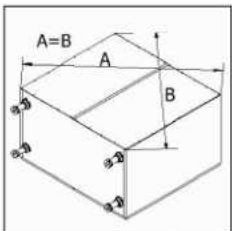
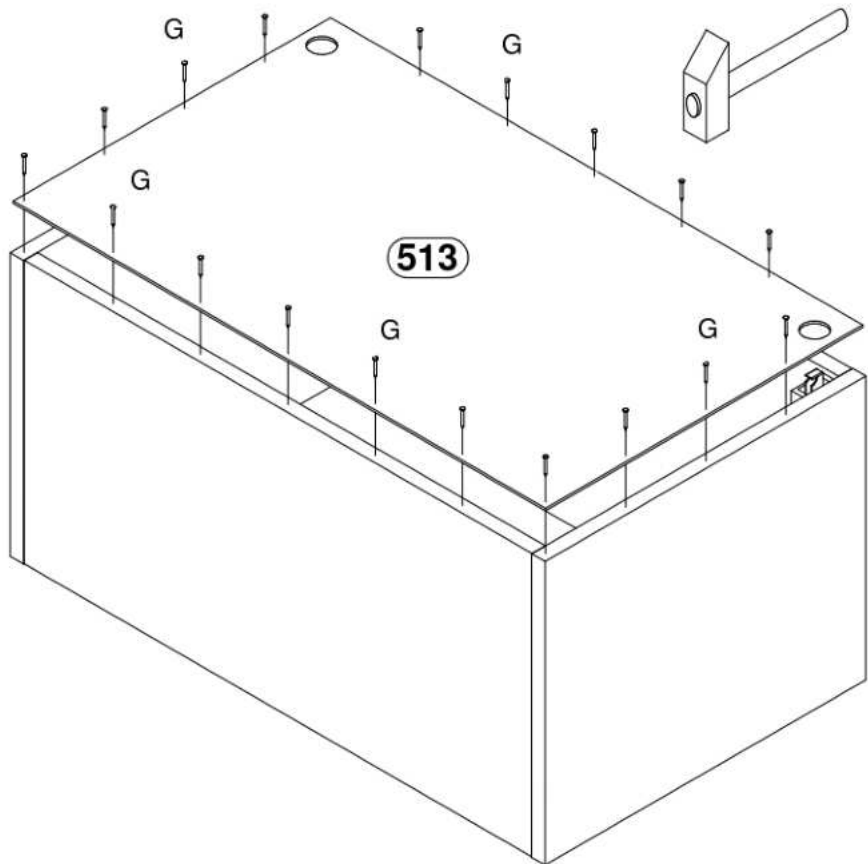

5

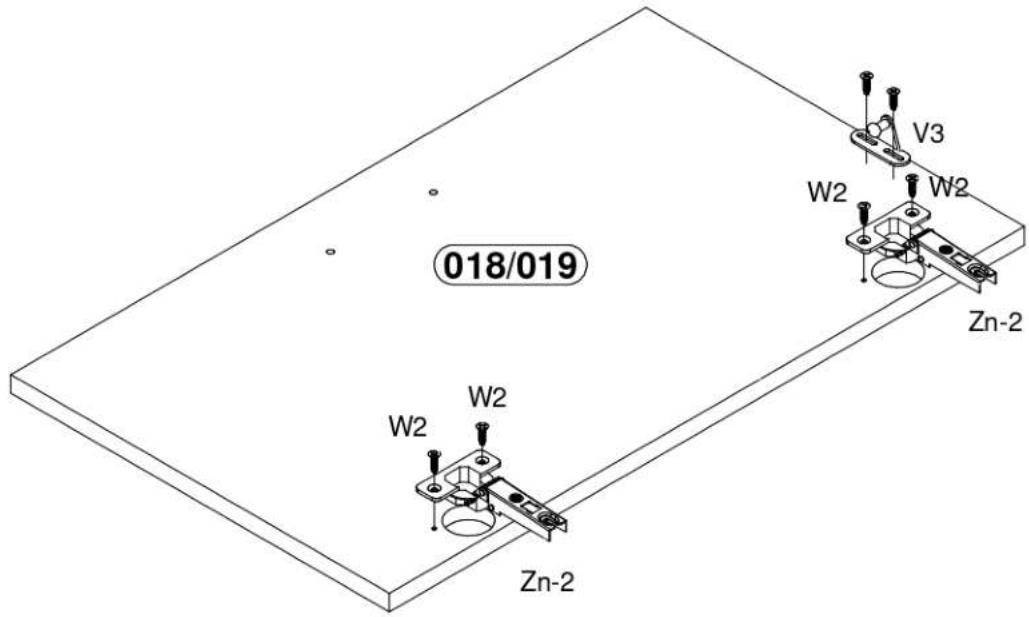

6

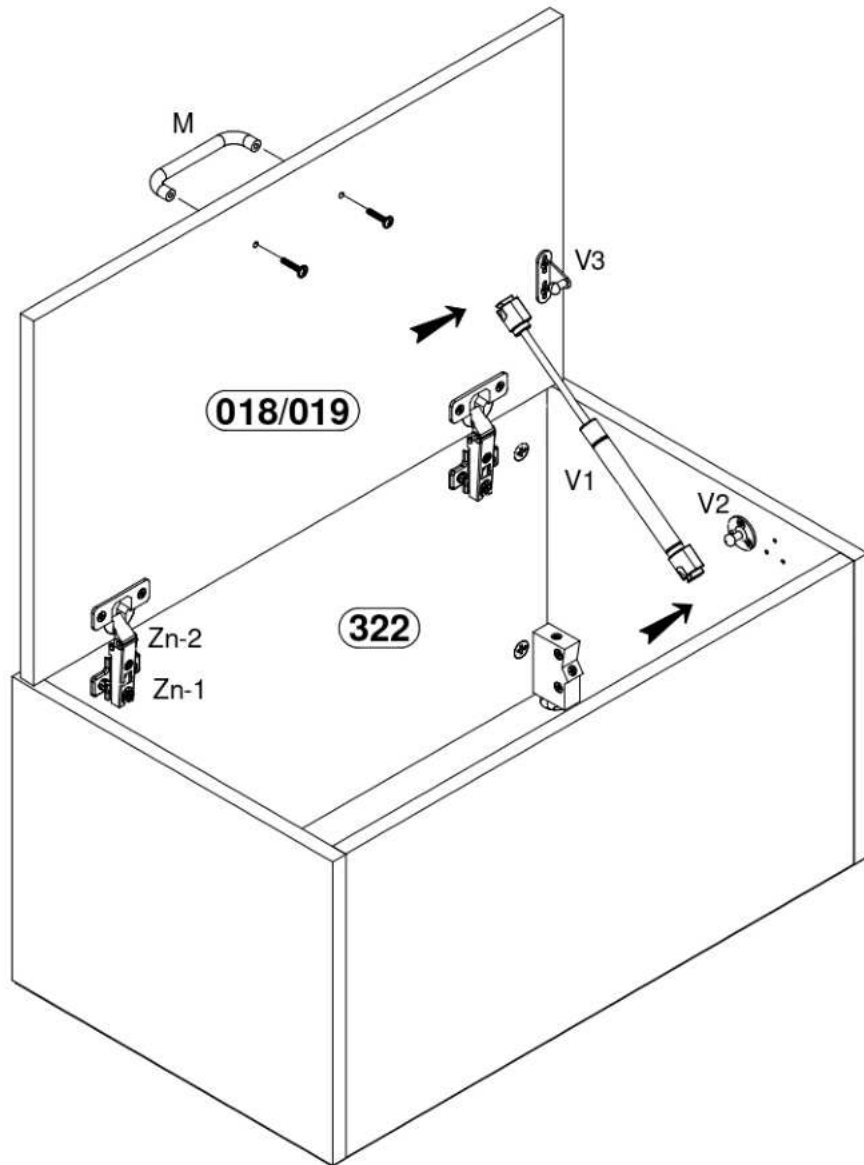

7

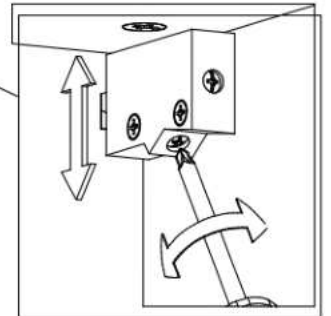
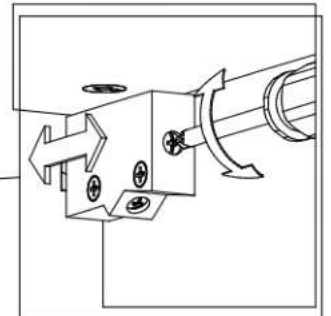
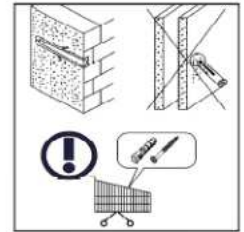
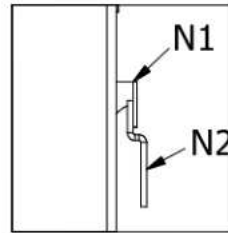
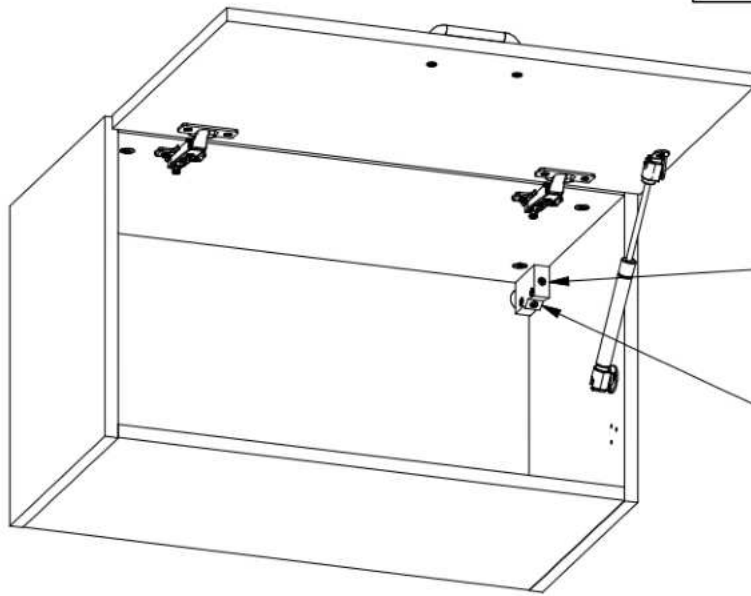

8

